



Filtration Handbook



Clear Selection. Ultimate Protection.

200 SOUTH FOURTH STREET · ALBION, IL 62806-1313

Filter Hot Line: 800-882-0890

WWW.PETROCLEAR.COM

MEMBER: FILTER MANUFACTURERS COUNCIL
MEMBER: PETROLEUM EQUIPMENT INSTITUTE



PetroClear® is a technological product of Champion Laboratories, Inc. Changes may occur based upon technology, process and material innovation as Champion Laboratories, Inc. strives to attain the highest levels of performance and customer satisfaction. These changes may occur without notification.

INTRODUCTION

Company Background

Established in 1998, the PetroClear® brand was founded on the basic principles of offering high-quality and competitively-priced dispenser filtration products commercialized through a best-in-class distribution network. PetroClear is part of Champion Laboratories, Inc., a global supplier of filtration solutions that has been manufacturing high-quality filtration products for more than 60 years.

Committed to providing innovative filter solutions, PetroClear® is dedicated to providing its customers with the highest quality filter products and customer service second to none.

PetroClear®. Clear Selection. Ultimate Protection.

QUALITY POLICY

It is the policy of PetroClear to maintain the highest standard of quality in all aspects of our operations and to continually satisfy the expectations of our customers.

We will provide our employees with all the necessary information, training, tools and support to achieve our business and quality objectives. We will also utilize our employees' input and suggestions to continuously improve the quality management system.

PetroClear is dedicated to continuous improvement in product development, supplier selection, production, and delivery of our products. Our ultimate goal is to provide superior filtration products and customer service excellence.

PetroClear designs, manufactures, and sells filtration products in accordance with requirements of Quality Systems and IATF16949 (2016 Edition).

NOTE: The policy suitability and objectives are reviewed annually by management.

NOTE: *If you experience frequent filter changes, it is recommended that you have fuel samples analyzed to determine the source of contamination, such as water, dirt, rust, bacteria, phase separation, etc.*

WARRANTY

CHAMPION LABORATORIES, INC. FILTER WARRANTY

Filters manufactured by Champion Laboratories, Inc. are warranted to be free from defects in material and workmanship. Any filter proven defective during the engine or equipment manufacturer's recommended service intervals will be replaced at no charge.

In the event of an engine or equipment failure directly caused by a defective Champion manufactured filter, which was properly installed and changed following the engine or equipment manufacturer's recommended service intervals, Champion Laboratories, Inc. will repair the damaged engine or equipment.

Claims for engine or equipment repairs provided under this warranty must be submitted within 30 days after discovery of damage. Champion Laboratories, Inc. Technical Service Department reserves the right to examine the engine or equipment and filter to determine the amount of damage and whether it was caused by a defective Champion manufactured filter.

This warranty gives you specific legal rights. You have other rights, which vary from state to state. Engine and equipment manufacturer's warranties remain in effect when Champion manufactured filters are used.

ENVIRONMENTAL POLICY STATEMENT

Our Environmental Policy supports our goal to be responsible citizens in the protection and preservation of our environment. We are committed to complying with accepted environmental practices including our commitment to:

- Operate within guidelines of all applicable legal and other requirements
- Strive for continuous improvement in our Environmental Management System
- Strive to prevent waste and pollution

We will strive to ensure that our business plans, internal procedures, and activities provide a setting where our environmental system, policy, objectives, and targets are continuously monitored, reviewed, and improved.

This Environmental Policy will be available to the public during normal business hours.

HISTORY

PetroClear is dedicated to developing and manufacturing fuel-dispensing filters for the demanding needs of today's retail and commercial fueling applications. As part of the Champion Laboratories, Inc., family of filtration products, the PetroClear brand has a history of engineering new filtration solutions for the fueling industry.

Today, PetroClear products are hard-at-work behind the scenes (and behind the sheet metal) at convenience stores, hypermarkets, service stations, unattended fueling facilities, marina fueling facilities, and fleet fueling facilities including municipal, hospital, school, rental car, farm and military facilities.

NOTE: *If you experience frequent filter changes, it is recommended that you have fuel samples analyzed to determine the source of contamination, such as water, dirt, rust, bacteria, phase separation, etc.*

CONTACT INFORMATION

PetroClear®

200 South Fourth Street
Albion, IL 62806-1313, USA

Customer Service/Order Entry

Customer Service:
championcustomerservice@champlabs.com

Accounts Receivable:
champlabsar@firstbrandsgroup.com

Claims Department:
csclaims@champlabs.com

Technical Service

Filter Hot Line
Phone: (800) 882-0890

PetroClear Business Director

Robert Ingham
Phone: (419) 708-0924
E-mail: robert.ingham@champlabs.com

PAYMENT INFORMATION

For ACH:

- Use Transit (ABA) Number 121000248
- Instruct Wells Fargo Bank, N.A. to deposit funds in:
Champion Laboratories, Inc. Receivables Account # 4386389092
Beneficiary Bank:
Wells Fargo Bank, N.A.
420 Montgomery
San Francisco, CA 94104

For Wires:

- Use Transit (ABA) Number 121000248
- Instruct Wells Fargo Bank, N.A. to deposit funds in:
Champion Laboratories Inc. Receivables Account # 4386389092
Beneficiary Bank:
Wells Fargo Bank, N.A.
420 Montgomery
San Francisco, CA 94104
Swift Code WFBIUS6S (for wires originating from outside the United States or Canada)
- Always send remittance information by email

For Checks:

- Please send check payments to this lockbox mailing address:
Champion Laboratories, Inc.
PO Box 780811
Philadelphia, PA 19178-0811

For Overnight Payments:

Contact Champion Laboratories, Inc. Credit Department
Phone: 1-800-851-3641 ext. 5412 or ext. 5409

The PetroClear® spin-on filter labels provide information about diameter, height, micron rating, function and more. Reference the guide below for an explanation of label features.

The color of the label/filter communicates what kind of filter it is:



RED

Particulate Removing Only



BROWN

Water Sensing & Particulate Removing



BLUE

Phase Separation Detection "Alert" & Particulate Removing



GREEN

Phase Separation Detection & Water Sensing & Particulate Removing

The model number communicates size, micron rating, function and application information:

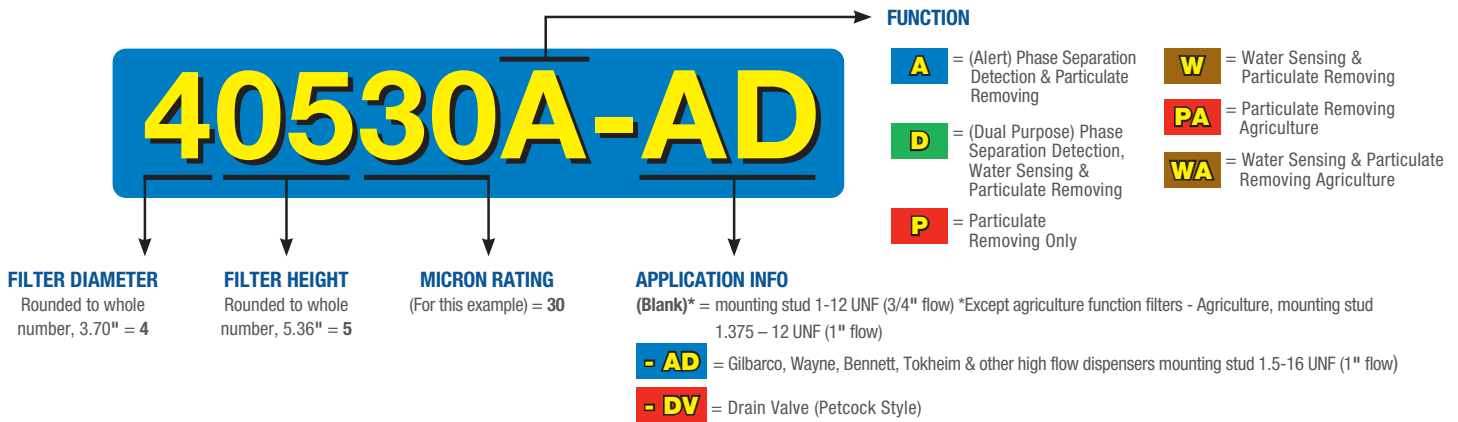

The label also includes safety, installation, performance, UL recognition and a bar code:

SAFETY INFO

INT'L SYMBOLS
For Installation

PERFORMANCE INFO

BAR CODE
Inventory Control

UL RECOGNITION
USA & Canada

WARNING / ATTENTION
FUEL SYSTEM PRESSURIZED FIRE HAZARD / SYSTÈME À COMBUSTIBLE PRESSURISÉ, RISQUE D'INCENDIE
READ AND FOLLOW ALL INSTRUCTIONS. FAILURE COULD RESULT IN FIRE, SERIOUS BODILY INJURY OR DEATH. / LIRE ET SUIVRE TOUTES LES INSTRUCTIONS, SINON IL PEUT EN RÉSULTER UN INCENDIE, DES BLESSURES GRAVES, OU LA MORT.

- Filter unit to be installed or changed by authorized trained service personnel only. Follow Dispenser Manufacturer's procedures. / L'appareil à filtre doit être installé ou changé par un technicien de service formé autorisé seulement. Observer les marches à suivre du fabricant de distributeur.
- NOT FOR USE WITH AVIATION FUEL. / NE PAS UTILISER AVEC DU CARBURANT D'AVIATION.**
- Use filters and fluids drained from filters must be contained and disposed of according to local regulations. Contact your nearest E.P.A. office for proper handling. / Les filtres usés et les fluides drainés des filtres doivent être contenus et jetés conformément aux règlements locaux. Communiquer avec le bureau de l'EPA visant la manipulation appropriée.

278-49638-0351

MAX. FLOW RATE: 25 GPM (94.6 LPM) / Taux de débit maximum: 94,6 L/min (25 gal/min)
MAX. OPER. PRESSURE: 50 PSI (3.4 BAR) / Pression opérationnelle maximale: 3,4 bars (50 lb/PO)
MICRON RATINGS: / COTE MICRON: 10

Technical Questions? / Questions techniques? 800-882-0890
Champion Laboratories Inc., 200 South Fourth St., Alton, Illinois 62806
Made in Mexico / Fabriqué au Mexique

UL US E0-95 B0-100

Detects phase separation and removes particulates in all ethanol fuel blends (E0-85) / Détecte la séparation des phases et élimine les particules dans tous les mélanges de carburant à l'éthanol (E0-85)

PetroClear®
ETHANOL ÉTHANOL
NOT FOR USE WITH DIESEL FUELS
NE PAS UTILISER AVEC LES CARBURANTS DIESEL
40510A-AD

NOTE: If you experience frequent filter changes, it is recommended that you have fuel samples analyzed to determine the source of contamination, such as water, dirt, rust, bacteria, phase separation, etc.

SPIN-ON FUEL FILTER

A Look Inside a PetroClear® Filter



The element assembly consists of the following: Pleated filter media which removes contaminants from the fuel. Metal end caps, plus thermo-setting adhesive, providing positive seals, which prevent the by-pass of contaminated fuel. The core provides strength and support to the pleated media. The cover backplate assembly consists of a threaded backplate formed from thick steel for strength, a gasket retainer and a sealing gasket. The cover and backplate assembly is roll seamed to the shell to provide a leak proof assembly on all dispenser filters. A coil spring keeps pressure on the element and all internal components to ensure proper filter operations.

* On select filters

NOTE: If you experience frequent filter changes, it is recommended that you have fuel samples analyzed to determine the source of contamination, such as water, dirt, rust, bacteria, phase separation, etc.

PRODUCT Information



NOTE: If you experience frequent filter changes, it is recommended that you have fuel samples analyzed to determine the source of contamination, such as water, dirt, rust, bacteria, phase separation, etc.

405 Series “Alert”

Particulate Removal and Phase Separation Detection In Alcohol Blended Fuels



40510A and 40530A

Detects Phase Separation in
Ethanol Blended Gasoline

FOR DISPOSAL INFORMATION PLEASE CONTACT YOUR NEAREST EPA OFFICE.

Benefits

- PetroClear® models 40510A and 40530A are spin-on filters designed to remove particulate, detect and stop flow of phase separation (Ethanol water) in Ethanol blended fuels.
- The “Alert” models 40510A and 40530A are designed to remove particulate and to detect and react to phase separation in Ethanol blended gasoline and slow flow as an indicator to the presence of phase separation. IT WILL NOT SENSE NOR REACT TO WATER IN NON-ALCOHOL BLENDED GASOLINE (NEAT GASOLINE).
- PetroClear® model 40510A filter offers efficient 10 micron (nominal) particulate removal and detects phase separation.
- PetroClear® model 40530A filter offers efficient 30 micron (nominal) particulate removal and detects phase separation.
- Textured paint coating helps ensure a simple, mess-free installation and removal process.
- UL® recognized

PetroClear® Filters are NOT to be used in Aviation Fuel Applications!

Specifications

- The PetroClear® model 40510A utilizes a 10 micron (nominal) cellulose media to remove particulate from Ethanol blended gasoline. Removes particulate 10 microns (nominal) or larger.
- The PetroClear® model 40530A utilizes a 30 micron (nominal) cellulose media to remove particulate from Ethanol blended gasoline. Removes particulate 30 microns (nominal) or larger.
- The “Alert” models 40510A and 40530A are designed to detect and react to phase separation in Ethanol blended gasoline.
- The maximum flow rate for PetroClear® models 40510A and 40530A is 25 gpm (94.6 lpm). Maximum operating pressure is 50 psid (3.4 bar). Collapse pressure is 150 psid (10.3 bar). Maximum operating temperature is 250°F (139°C).
- The chemical center core assembly detects and reacts to phase separation and significantly restricts flow through filters.
- PetroClear® models 40510A and 40530A utilize a standard 1"-12 UNF mounting thread ref. (3/4" flow) required for most spin-on filter adapters used in aftermarket.
- Adapters are available for models 40510A and 40530A in aluminum and cast iron. These single adapters are available in both 3/4" and 1" NPT or BSP inlet/outlet threads.

NOTE: If you experience frequent filter changes, it is recommended that you have fuel samples analyzed to determine the source of contamination, such as water, dirt, rust, bacteria, phase separation, etc.

40510A and 40530A Series the “Alert”

Detects Phase Separation

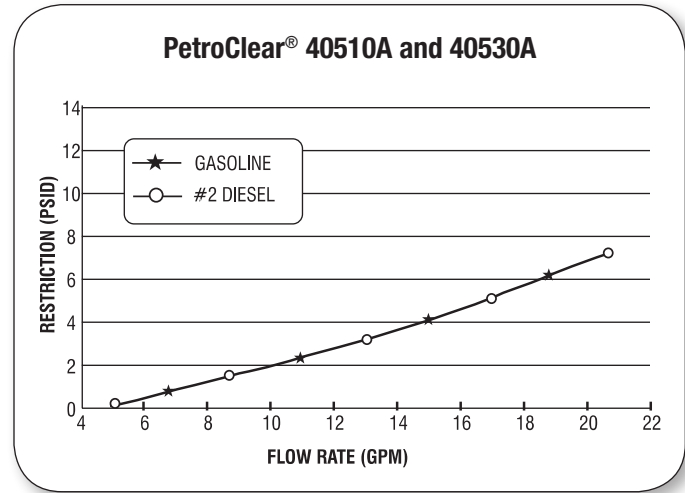
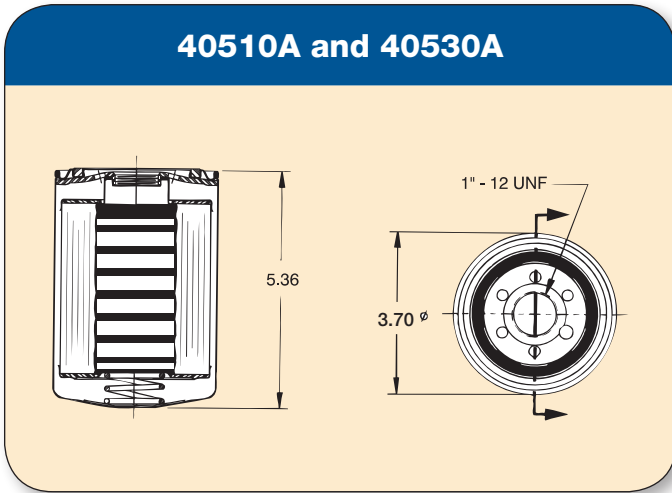

Model	40510A	40530A
Filter Type	Spin-On	Spin-On
Media Type	*Cellulose with Chemical Core	*Cellulose with Chemical Core
Micron Rating	10 Micron (nominal)	30 Micron (nominal)
Diameter	3.70"	3.70"
Height	5.36"	5.36"
Mounting Thread	1" – 12 UNF	1" – 12 UNF
Flow Rate	25 gpm (94.6 lpm)	25 gpm (94.6 lpm)
Flow	3/4" flow	3/4" flow
Shell Thickness	0.020	0.020
Gasket Material	Buna N	Buna N
Collapse (Min.)	150 psid (10.3 bar)	150 psid (10.3 bar)
Burst (Min.)	250 psi (17.2 bar)	250 psi (17.2 bar)
Max. Operating Temp.	250°F (139°C)	250°F (139°C)
Min. Operating Temp.	-20°F (-28.9°C)	-20°F (-28.9°C)

*Particulate Removing and Chemical Core Detects Phase Separation

Available Adapters

Part/Model Number	Description
.75 N1-12	3/4" NPT Inlet/Outlet Ports, 1" – 12 UNF (cast iron)
.75 N1-12A	3/4" NPT Inlet/Outlet Ports, 1" – 12 UNF (aluminum)
1.00N-12	1" NPT Inlet/Outlet Ports, 1" – 12 UNF (cast iron)
1.00N1-12A	1" NPT Inlet/Outlet Ports, 1" – 12 UNF (aluminum)
.75 B1-12	3/4" BSP Inlet/Outlet Ports, 1" – 12 UNF (aluminum)
1.00B1-12	1" BSP Inlet/Outlet Ports, 1" – 12 UNF (aluminum)

405 Series

Particulate Removing



**40502P, 40505P,
40510P and 40530P**

For Fuel Dispensers

Benefits

- PetroClear® models 40502P, 40505P, 40510P and 40530P are particulate removing spin-on filters designed to remove particulate from neat gasoline, Ethanol blended gasolines, diesels, Biodiesel, ULSD (Ultra Low Sulfur Diesel), kerosene and fuel oils.
- PetroClear® models 40502P, 40505P, 40510P and 40530P are particulate spin-on filters. These filters are designed for particulate removal only and WILL NOT REACT TO WATER IN FUELS OR PHASE SEPARATION IN ETHANOL BLENDED GASOLINES TO SLOW FLOW.
- PetroClear® model 40502P filter offers efficient 2 micron (nominal) particulate removal.
- PetroClear® model 40505P filter offers efficient 5 micron (nominal) particulate removal.
- PetroClear® model 40510P filter offers efficient 10 micron (nominal) particulate removal.
- PetroClear® model 40530P filter offers efficient 30 micron (nominal) particulate removal.
- Textured paint coating helps ensure a simple, mess-free installation and removal process.
- UL® recognized

PetroClear® Filters are NOT to be used in Aviation Fuel Applications!

FOR DISPOSAL INFORMATION PLEASE CONTACT YOUR NEAREST EPA OFFICE.

Specifications

- The PetroClear® model 40502P utilizes a 2 micron (nominal) cellulose media to remove particulate from gasolines and diesel fuels including Ethanol blended gasolines, Biodiesel and ULSD (Ultra Low Sulfur Diesel). Removes particulate 2 microns (nominal) or larger.
- The PetroClear® model 40505P utilizes a 5 micron (nominal) cellulose media to remove particulate from gasolines and diesel fuels including Ethanol blended gasolines, Biodiesel and ULSD (Ultra Low Sulfur Diesel). Removes particulate 5 microns (nominal) or larger.
- The PetroClear® model 40510P utilizes a 10 micron (nominal) cellulose media to remove particulate from gasolines and diesel fuels including Ethanol blended gasolines, Biodiesel and ULSD (Ultra Low Sulfur Diesel). Removes particulate 10 microns (nominal) or larger.
- The PetroClear® model 40530P utilizes a 30 micron (nominal) cellulose media to remove particulate from gasolines and diesel fuels including Ethanol blended gasolines, Biodiesel and ULSD (Ultra Low Sulfur Diesel). Removes particulate 30 microns (nominal) or larger.
- The maximum flow rate for PetroClear® models 40502P, 40505P, 40510P and 40530P is 25 gpm (94.6 lpm). Maximum operating pressure is 50 psid (3.4 bar). Collapse pressure is 150 psid (10.3 bar). Maximum operating temperature is 250°F (139°C).
- PetroClear® models 40502P, 40505P, 40510P and 40530P utilize a standard 1"-12 UNF mounting thread ref. (3/4" flow) required for most spin-on filter Adapters used in Gilbarco, Wayne, Bennet, Tokheim and other major manufacturers' dispensers, as well as with Adapters used in the aftermarket.
- Adapters are available for models 40502P, 40505P, 40510P and 40530P in aluminum and cast iron. These single Adapters are available in 3/4" and 1" NPT or BSP inlet/outlet threads.

NOTE: If you experience frequent filter changes, it is recommended that you have fuel samples analyzed to determine the source of contamination, such as water, dirt, rust, bacteria, phase separation, etc.

40502P, 40505P, 40510P and 40530P

For Fuel Dispensers

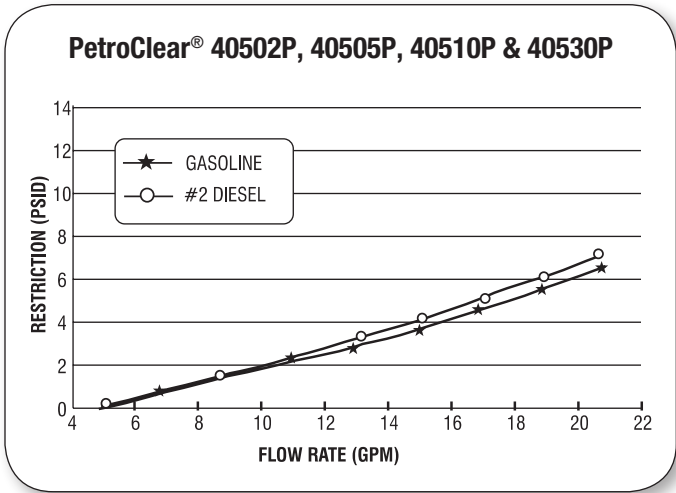
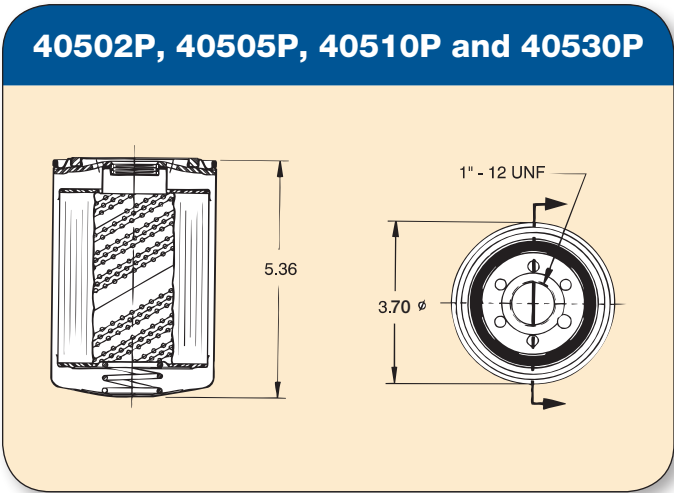

Model	40502P	40505P	40510P	40530P
Filter Type	Spin-On	Spin-On	Spin-On	Spin-On
Media Type	*Cellulose	* Cellulose	* Cellulose	* Cellulose
Micron Rating	2 Micron (nominal)	5 Micron (nominal)	10 Micron (nominal)	30 Micron (nominal)
Diameter	3.70"	3.70"	3.70"	3.70"
Height	5.36"	5.36"	5.36"	5.36"
Mounting Thread	1" – 12 UNF	1" – 12 UNF	1" – 12 UNF	1" – 12 UNF
Flow Rate	25 gpm (94.6 lpm)	25 gpm (94.6 lpm)	25 gpm (94.6 lpm)	25 gpm (94.6 lpm)
Flow	3/4" flow	3/4" flow	3/4" flow	3/4" flow
Shell Thickness	0.020	0.020	0.020	0.020
Gasket Material	Buna N	Buna N	Buna N	Buna N
Collapse (Min.)	150 psid (10.3 bar)	150 psid (10.3 bar)	150 psid (10.3 bar)	150 psid (10.3 bar)
Burst (Min.)	250 psi (17.2 bar)	250 psi (17.2 bar)	250 psi (17.2 bar)	250 psi (17.2 bar)
Max. Operating Temp.	250°F (139°C)	250°F (139°C)	250°F (139°C)	250°F (139°C)

*Particulate Removing

Available Adapters

Part/Model Number	Description
.75 N1-12	3/4" NPT Inlet/Outlet Ports, 1" – 12 UNF (cast iron)
.75 N1-12A	3/4" NPT Inlet/Outlet Ports, 1" – 12 UNF (aluminum)
1.00N-12	1" NPT Inlet/Outlet Ports, 1" – 12 UNF (cast iron)
1.00N1-12A	1" NPT Inlet/Outlet Ports, 1" – 12 UNF (aluminum)
.75 B1-12	3/4" BSP Inlet/Outlet Ports, 1" – 12 UNF (aluminum)
1.00B1-12	1" BSP Inlet/Outlet Ports, 1" – 12 UNF (aluminum)

405 Series-AD “Alert”

Particulate Removal and Phase Separation Detection In Alcohol Blended Fuels



40510A-AD and 40530A-AD

Detects Phase Separation in
Ethanol Blended Gasoline

FOR DISPOSAL INFORMATION PLEASE CONTACT YOUR NEAREST EPA OFFICE.

Benefits

- PetroClear® models 40510A-AD and 40530A-AD are spin-on filters designed to remove particulate, detect and stop flow of phase separation (Ethanol water) in Ethanol blended fuels.
- The “Alert” models 40510A-AD and 40530A-AD are designed to remove particulate and to detect and react to phase separation in Ethanol blended gasoline and slow flow as an indicator to the presence of phase separation. IT WILL NOT SENSE NOR REACT TO WATER IN NON-ALCOHOL BLENDED GASOLINE (NEAT GASOLINE).
- PetroClear® model 40510A-AD filter offers efficient 10 micron (nominal) particulate removal and detects phase separation.
- PetroClear® model 40530A-AD filter offers efficient 30 micron (nominal) particulate removal and detects phase separation.
- Textured paint coating helps ensure a simple, mess-free installation and removal process.
- UL® recognized

PetroClear® Filters are NOT to be used in Aviation Fuel Applications!

Specifications

- The PetroClear® model 40510A-AD utilizes a 10 micron (nominal) cellulose media to remove particulate from Ethanol blended gasoline. Removes particulate 10 microns (nominal) or larger.
- The PetroClear® model 40530A-AD utilizes a 30 micron (nominal) cellulose media to remove particulate from Ethanol blended gasoline. Removes particulate 30 microns (nominal) or larger.
- The “Alert” models 40510A-AD and 40530A-AD are designed to detect and react to phase separation in Ethanol blended gasoline.
- The maximum flow rate for PetroClear® models 40510A-AD and 40530A-AD is 25 gpm (94.6 lpm). Maximum operating pressure is 50 psid (3.4 bar). Collapse pressure is 150 psid (10.3 bar). Maximum operating temperature is 250°F (139°C).
- The chemical center core assembly detects and reacts to phase separation and significantly restricts flow through filters.
- PetroClear® models 40510A-AD and 40530A-AD utilize a standard 1.5"-16 UNF mounting thread ref. (1" flow) required for most spin-on filter adapters used in aftermarket.
- Adapters are available for models 40510A-AD and 40530A-AD in aluminum. These single adapters are available in both 3/4" and 1" NPT or BSP inlet/outlet threads.

NOTE: If you experience frequent filter changes, it is recommended that you have fuel samples analyzed to determine the source of contamination, such as water, dirt, rust, bacteria, phase separation, etc.

40510A-AD and 40530A-AD Series The “Alert” Detects Phase Separation

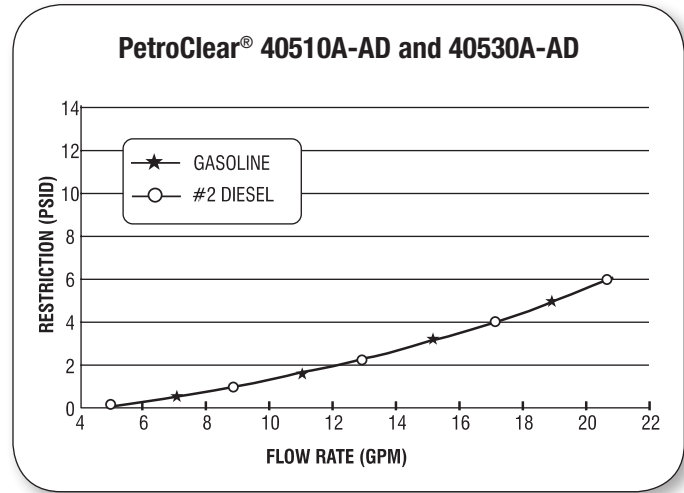
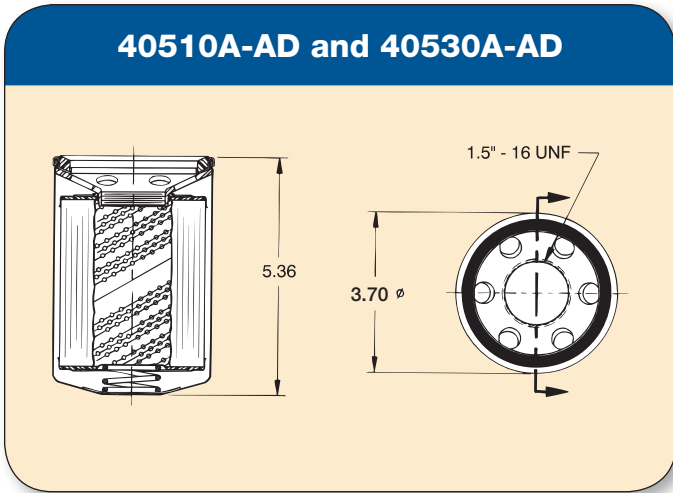

Model	40510A-AD	40530A-AD
Filter Type	Spin-On	Spin-On
Media Type	*Cellulose with Chemical Core	*Cellulose with Chemical Core
Micron Rating	10 Micron (nominal)	30 Micron (nominal)
Diameter	3.70"	3.70"
Height	5.36"	5.36"
Mounting Thread	1.5" – 16 UNF	1.5" – 16 UNF
Flow Rate	25 gpm (94.6 lpm)	25 gpm (94.6 lpm)
Flow	1" flow	1" flow
Shell Thickness	0.020	0.020
Gasket Material	Buna N	Buna N
Collapse (Min.)	150 psid (10.3 bar)	150 psid (10.3 bar)
Burst (Min.)	500 psi (34.5 bar)	500 psi (34.5 bar)
Max. Operating Temp.	250°F (139°C)	250°F (139°C)
Min. Operating Temp.	-20°F (-28.9°C)	-20°F (-28.9°C)

*Particulate Removing and Chemical Core Detects Phase Separation

Available Adapters

Part/Model Number	Description
.75 N1.5-16AD	3/4" NPT Inlet/Outlet Ports, 1.5" – 16 UNF (aluminum)
1.0 N1.5-16AD	1" NPT Inlet/Outlet Ports, 1.5" – 16 UNF (aluminum)
.75B1.5-16ADA	3/4" BSP Inlet/Outlet Ports, 1"-16 UNF (aluminum)
1.00B1.5-16ADA	1" BSP Inlet/Outlet Ports, 1"-16 UNF (aluminum)

405-AD Series

Particulate Removing



**40502P-AD, 40505P-AD,
40510P-AD and 40530P-AD**

For High-Flow Fuel Dispensers

FOR DISPOSAL INFORMATION PLEASE CONTACT YOUR NEAREST EPA OFFICE.

Benefits

- PetroClear® models 40502P-AD, 40505P-AD, 40510P-AD and 40530P-AD are particulate removing spin-on filters designed to remove particulate from neat gasoline, Ethanol blended gasolines, diesels, Biodiesel, ULSD (Ultra Low Sulfur Diesel), kerosene and fuel oils.
- PetroClear® models 40502P-AD, 40505P-AD, 40510P-AD and 40530P-AD are particulate removing spin-on filters. These filters are designed for particulate removal only and WILL NOT REACT TO WATER IN FUELS OR PHASE SEPARATION IN ETHANOL BLENDED GASOLINE TO SLOW FLOW.
- PetroClear® model 40502P-AD filter offers efficient 2 micron (nominal) particulate removal.
- PetroClear® model 40505P-AD filter offers efficient 5 micron (nominal) particulate removal.
- PetroClear® model 40510P-AD filter offers efficient 10 micron (nominal) particulate removal.
- PetroClear® model 40530P-AD filter offers efficient 30 micron (nominal) particulate removal.
- Compatible with neat gasoline, Ethanol blended fuels and all diesels, including Biodiesel fuels.
- Textured paint coating helps ensure a simple, mess-free installation and removal process.
- UL® recognized

PetroClear® Filters are NOT to be used in Aviation Fuel Applications!

Specifications

- The PetroClear® model 40502P-AD utilizes a 2 micron (nominal) cellulose media to remove particulate from gasolines and diesel fuels including Ethanol blended gasoline, Biodiesel and ULSD (Ultra Low Sulfur Diesel). Removes particulate 2 microns (nominal) or larger.
- The PetroClear® model 40505P-AD utilizes a 5 micron (nominal) cellulose media to remove particulate from gasolines and diesel fuels including Ethanol blended gasoline, Biodiesel and ULSD (Ultra Low Sulfur Diesel). Removes particulate 5 microns (nominal) or larger.
- The PetroClear® model 40510P-AD utilizes a 10 micron (nominal) cellulose media to remove particulate from gasolines and diesel fuels including Ethanol blended gasoline, Biodiesel and ULSD (Ultra Low Sulfur Diesel). Removes particulate 10 microns (nominal) or larger.
- The PetroClear® model 40530P-AD utilizes a 30 micron (nominal) cellulose media to remove particulate from gasolines and diesel fuels including Ethanol blended gasoline, Biodiesel and ULSD (Ultra Low Sulfur Diesel). Removes particulate 30 microns (nominal) or larger.
- The maximum flow rate for PetroClear® models 40502P-AD, 40505P-AD, 40510P-AD and 40530P-AD is 25 gpm (94.6 lpm). Maximum operating pressure is 50 psid (3.4 bar). Collapse pressure is 150 psid (10.3 bar). Maximum operating temperature is 250°F (139°C).
- PetroClear® models 40502P-AD, 40505P-AD, 40510P-AD and 40530P-AD utilize a standard 1.5" – 16 UNF mounting thread ref. (1" flow) required for most spin-on filter Adapters used in aftermarket and/or high-flow applications such as Gilbarco, Wayne, Bennet, Tokheim and other major manufacturers' dispensers.
- Adapters are available for models 40502P-AD, 40505P-AD, 40510P-AD and 40530P-AD in aluminum. These single Adapters are available in 3/4" and 1" NPT and BSP inlet/outlet threads.

NOTE: If you experience frequent filter changes, it is recommended that you have fuel samples analyzed to determine the source of contamination, such as water, dirt, rust, bacteria, phase separation, etc.

40502P-AD, 40505P-AD, 40510P-AD & 40530P-AD

For High-Flow Fuel Dispensers

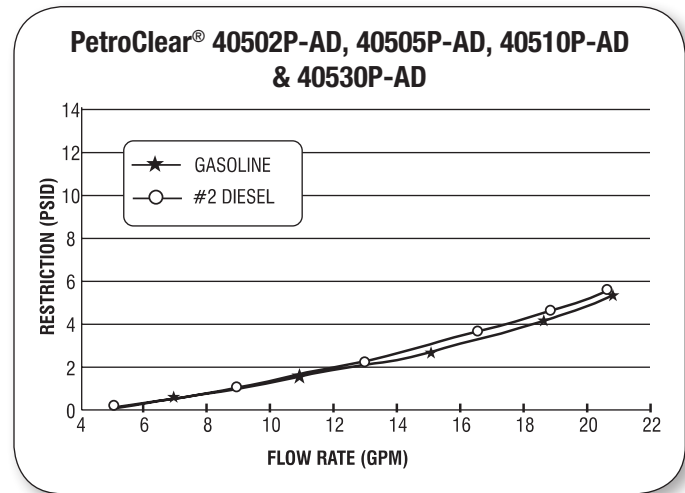
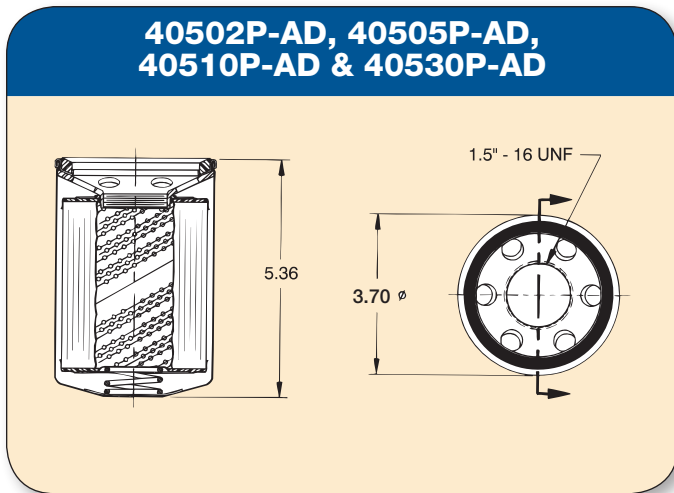

Model	40502P-AD	40505P-AD	40510P-AD	40530P-AD
Filter Type	Spin-On	Spin-On	Spin-On	Spin-On
Media Type	*Cellulose	* Cellulose	* Cellulose	* Cellulose
Micron Rating	2 Micron (nominal)	5 Micron (nominal)	10 Micron (nominal)	30 Micron (nominal)
Diameter	3.70"	3.70"	3.70"	3.70"
Height	5.36"	5.36"	5.36"	5.36"
Mounting Thread	1.5" – 16 UNF	1.5" – 16 UNF	1.5" – 16 UNF	1.5" – 16 UNF
Flow Rate	25 gpm (94.6 lpm)	25 gpm (94.6 lpm)	25 gpm (94.6 lpm)	25 gpm (94.6 lpm)
Flow	1" flow	1" flow	1" flow	1" flow
Shell Thickness	0.020	0.020	0.020	0.020
Gasket Material	Buna N	Buna N	Buna N	Buna N
Collapse (Min.)	150 psid (10.3 bar)	150 psid (10.3 bar)	150 psid (10.3 bar)	150 psid (10.3 bar)
Burst (Min.)	500 psi (34.5 bar)	500 psi (34.5 bar)	500 psi (34.5 bar)	500 psi (34.5 bar)
Max. Operating Temp.	250°F (139°C)	250°F (139°C)	250°F (139°C)	250°F (139°C)

*Particulate Removing

Available Adapters

Part/Model Number	Description
.75 N1.5-16AD	3/4" NPT Inlet/Outlet Ports, 1.5" – 16 UNF (aluminum)
1.0 N1.5-16AD	1" NPT Inlet/Outlet Ports, 1.5" – 16 UNF (aluminum)
.75B1.5-16ADA	3/4" BSP Inlet/Outlet Ports, 1"-16 UNF (aluminum)
1.00B1.5-16ADA	1" BSP Inlet/Outlet Ports, 1"-16 UNF (aluminum)

405 Series

Particulate Removing & Water Sensing



FOR DISPOSAL INFORMATION PLEASE CONTACT YOUR NEAREST EPA OFFICE.

Specifications

- The PetroClear® model 40510W utilizes a 10 micron (nominal) cellulose media to remove particulate from gasolines and diesel fuels including Biodiesel and ULSD (Ultra Low Sulfur Diesel). Removes particulate 10 microns (nominal) or larger. This filter utilizes a super absorbent chemical that is laminated to the filter media for water sensing capabilities in neat gasoline and diesel fuels.
- The PetroClear® model 40530W utilizes a 30 micron (nominal) cellulose media to remove particulate from gasolines and diesel fuels including Biodiesel and ULSD (Ultra Low Sulfur Diesel). Removes particulate 30 microns (nominal) or larger. It utilizes a super absorbent chemical that is laminated to the filter media for water sensing capabilities in neat gasoline and diesel applications.
- When PetroClear® models 40510W and 40530W absorb 5.9 ounces (175 mil) of water from neat gasoline or diesel fuels, flow will be noticeably slow.
- The maximum flow rate for PetroClear® models 40510W and 40530W is 25 gpm (94.6 lpm). Maximum operating pressure is 50 psid (3.4 bar). Collapse pressure is 150 psid (10.3 bar). Maximum operating temperature is 250°F (139°C).
- PetroClear® models 40510W and 40530W utilize a standard 1"-12 UNF mounting thread ref. (3/4" flow) required for most spin-on filter Adapters used in aftermarket and/or high-flow applications such as Gilbarco, Wayne, Bennet, Tokheim and other major manufacturers' dispensers.
- Adapters are available for models 40510W and 40530W in aluminum and cast iron. These single Adapters are available in 3/4" and 1" NPT or BSP inlet/outlet threads.

Benefits

- PetroClear® models 40510W and 40530W are particulate removing and water sensing spin-on filters designed to remove particulate and to sense both free and emulsified water from neat gasoline, diesel, Biodiesel, ULSD (Ultra Low Sulfur Diesel), kerosene and fuel oils.
- PetroClear® models 40510W and 40530W are particulate and water sensing spin-on filters. These filters are designed to sense water, both free and emulsified, and slow flow as an indicator of the presence of water in neat gasoline and diesel fuels. This filter will not sense nor react to water in Ethanol blended gasoline. (Reaction known as phase separation)
- PetroClear® model 40510W filter offers efficient 10 micron (nominal) particulate removal and senses both free and emulsified water in neat gasoline and diesel fuels.
- PetroClear® model 40530W filter offers efficient 30 micron (nominal) particulate removal and senses both free and emulsified water in neat gasoline and diesel fuels.
- Textured paint coating helps ensure a simple, mess-free installation and removal process.
- UL® recognized
- Will not detect phase separation in Ethanol blended fuels.

PetroClear® Filters are NOT to be used in Aviation Fuel Applications!

NOTE: If you experience frequent filter changes, it is recommended that you have fuel samples analyzed to determine the source of contamination, such as water, dirt, rust, bacteria, phase separation, etc.

40510W and 40530W

For Fuel Dispensers

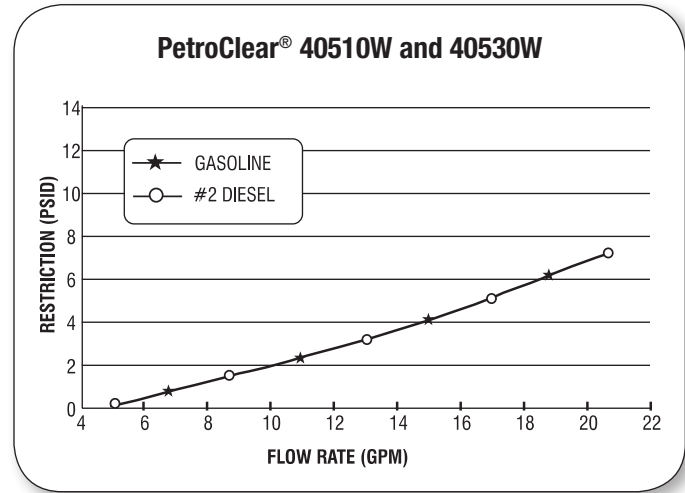
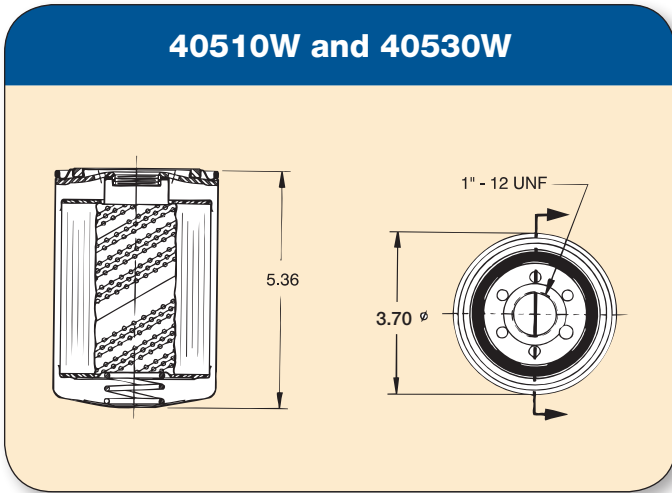

Model	40510W	40530W
Filter Type	Spin-On	Spin-On
Media Type	*Cellulose with Super Absorbent Media	*Cellulose with Super Absorbent Media
Micron Rating	10 Micron (nominal)	30 Micron (nominal)
Diameter	3.70"	3.70"
Height	5.36"	5.36"
Mounting Thread	1" – 12 UNF	1" – 12 UNF
Flow Rate	25 gpm (94.6 lpm)	25 gpm (94.6 lpm)
Flow	3/4" flow	3/4" flow
Shell Thickness	0.020	0.020
Gasket Material	Buna N	Buna N
Collapse (Min.)	150 psid (10.3 bar)	150 psid (10.3 bar)
Burst (Min.)	250 psi (17.2 bar)	250 psi (17.2 bar)
Max. Operating Temp.	250°F (139°C)	250°F (139°C)
Min. Operating Temp.	-20°F (-28.9°C)	-20°F (-28.9°C)

*Water Sensing and Particulate Removing

Available Adapters

Part/Model Number	Description
.75 N1-12	3/4" NPT Inlet/Outlet Ports, 1" – 12 UNF (cast iron)
.75 N1-12A	3/4" NPT Inlet/Outlet Ports, 1" – 12 UNF (aluminum)
1.00N-12	1" NPT Inlet/Outlet Ports, 1" – 12 UNF (cast iron)
1.00N1-12A	1" NPT Inlet/Outlet Ports, 1" – 12 UNF (aluminum)
.75 B1-12	3/4" BSP Inlet/Outlet Ports, 1" – 12 UNF (aluminum)
1.00B1-12	1" BSP Inlet/Outlet Ports, 1" – 12 UNF (aluminum)

405-AD Series

Particulate Removing & Water Sensing



FOR DISPOSAL INFORMATION PLEASE CONTACT YOUR NEAREST EPA OFFICE.

Benefits

- PetroClear® models 40505W-AD, 40510W-AD and 40530W-AD are particulate removing and water sensing spin-on filters designed to remove particulate and to sense both free and emulsified water from neat gasoline, diesel, Biodiesel, ULSD (Ultra Low Sulfur Diesel), kerosene and fuel oils.
- PetroClear® models 40505W-AD, 40510W-AD and 40530W-AD are particulate and water sensing spin-on filters. These filters are designed to sense water, both free and emulsified, and slow flow as an indicator of the presence of water in neat gasoline and diesel fuels. This filter will not sense nor react to water in Ethanol blended gasoline. (Reaction known as phase separation)
- PetroClear® model 40505W-AD filter offers efficient 5 micron (nominal) particulate removal and senses both free and emulsified water in neat gasoline and diesel fuels.
- PetroClear® model 40510W-AD filter offers efficient 10 micron (nominal) particulate removal and senses both free and emulsified water in neat gasoline and diesel fuels.
- PetroClear® model 40530W-AD filter offers efficient 30 micron (nominal) particulate removal and senses both free and emulsified water in neat gasoline and diesel fuels.
- Will not detect phase separation in Ethanol blended fuels.
- Textured paint coating helps ensure a simple, mess-free installation and removal process.
- UL® recognized

PetroClear® Filters are NOT to be used in Aviation Fuel Applications!

Specifications

- The PetroClear® model 40505W-AD utilizes a 5 micron (nominal) cellulose media to remove particulate from gasolines and diesel fuels including Biodiesel and ULSD (Ultra Low Sulfur Diesel). Removes particulate 5 microns (nominal) or larger. It utilizes a super absorbent chemical that is laminated to the filter media for water sensing capabilities in neat gasoline and diesel fuels.
- The PetroClear® model 40510W-AD utilizes a 10 micron (nominal) cellulose media to remove particulate from gasolines and diesel fuels including Biodiesel and ULSD (Ultra Low Sulfur Diesel). Removes particulate 10 microns (nominal) or larger. It utilizes a super absorbent chemical that is laminated to the filter media for water sensing capabilities in neat gasoline and diesel fuels.
- The PetroClear® model 40530W-AD utilizes a 30 micron (nominal) cellulose media to remove particulate from gasolines and diesel fuels including Biodiesel and ULSD (Ultra Low Sulfur Diesel). Removes particulate 30 microns (nominal) or larger. It utilizes a super absorbent chemical that is laminated to the filter media for water sensing capabilities in neat gasoline and diesel fuels.
- When PetroClear® models 40505W-AD, 40510W-AD and 40530W-AD absorb 5.9 ounces (175 mil) of water from neat gasoline or diesel fuels, flow will be noticeably slow.
- The maximum flow rate for PetroClear® models 40505W-AD, 40510W-AD and 40530W-AD is 25 gpm (94.6 lpm). Maximum operating pressure is 50 psid (3.4 bar). Collapse pressure is 150 psid (10.3 bar). Maximum operating temperature is 250°F (139°C).
- PetroClear® models 40505W-AD, 40510W-AD and 40530W-AD utilize a standard 1.5"-16 UNF mounting thread ref. (1" flow) required for most spin-on filter Adapters used in aftermarket and/or high-flow applications such as Gilbarco, Wayne, Bennet, Tokheim and other major manufacturers' dispensers.
- Adapters are available for models 40505W-AD, 40510W-AD and 40530W-AD in aluminum. These single Adapters are available in 3/4" and 1" NPT or BSP inlet/outlet threads.

NOTE: If you experience frequent filter changes, it is recommended that you have fuel samples analyzed to determine the source of contamination, such as water, dirt, rust, bacteria, phase separation, etc.

40505W-AD, 40510W-AD and 40530W-AD

For High-Flow Dispensers

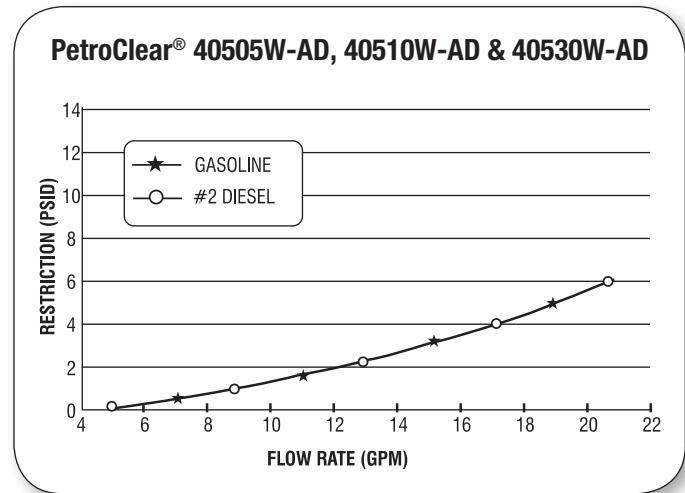
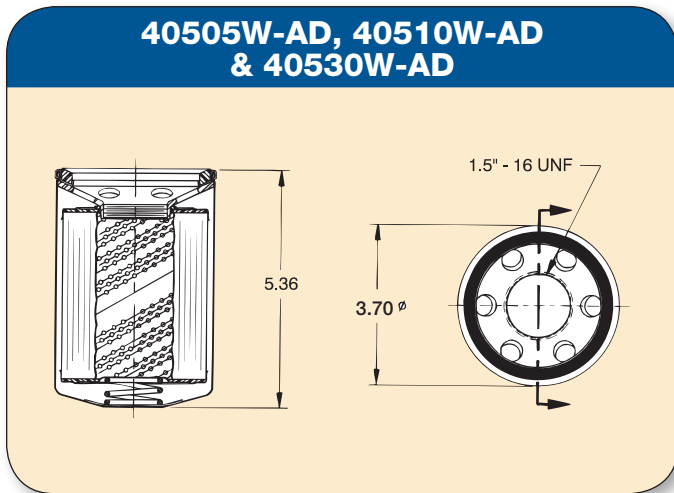

Model	40505W-AD	40510W-AD	40530W-AD
Filter Type	Spin-On	Spin-On	Spin-On
Media Type	*Cellulose with Super Absorbent Media	*Cellulose with Super Absorbent Media	*Cellulose with Super Absorbent Media
Micron Rating	5 Micron (nominal)	10 Micron (nominal)	30 Micron (nominal)
Diameter	3.70"	3.70"	3.70"
Height	5.36"	5.36"	5.36"
Mounting Thread	1.5" – 16 UNF	1.5" – 16 UNF	1.5" – 16 UNF
Flow Rate	25 gpm (94.6 lpm)	25 gpm (94.6 lpm)	25 gpm (94.6 lpm)
Flow	1" flow	1" flow	1" flow
Shell Thickness	0.020	0.020	0.020
Gasket Material	Buna N	Buna N	Buna N
Collapse (Min.)	150 psid (10.3 bar)	150 psid (10.3 bar)	150 psid (10.3 bar)
Burst (Min.)	500 psi (34.5 bar)	500 psi (34.5 bar)	500 psi (34.5 bar)
Max. Operating Temp.	250°F (139°C)	250°F (139°C)	250°F (139°C)
Min. Operating Temp.	-20°F (-28.9°C)	-20°F (-28.9°C)	-20°F (-28.9°C)

*Water Sensing in Neat Gasoline and Diesel Fuels

Available Adapters

Part/Model Number	Description
.75 N1.5-16AD	3/4" NPT Inlet/Outlet Ports, 1.5" – 16 UNF (aluminum)
1.0 N1.5-16AD	1" NPT Inlet/Outlet Ports, 1.5" – 16 UNF (aluminum)
.75B1.5-16ADA	3/4" BSP Inlet/Outlet Ports, 1"-16 UNF (aluminum)
1.00B1.5-16ADA	1" BSP Inlet/Outlet Ports, 1"-16 UNF (aluminum)

405 D Series “Dual Purpose”

Removes Particulate,
Detects Phase Separation & Senses Water

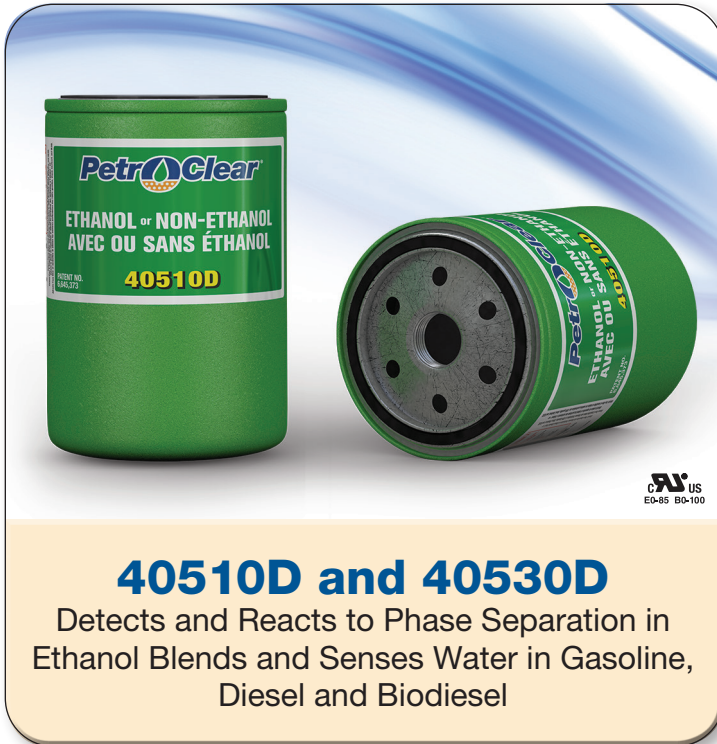
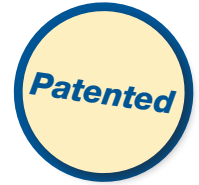

40510D and 40530D
Detects and Reacts to Phase Separation in
Ethanol Blends and Senses Water in Gasoline,
Diesel and Biodiesel

FOR DISPOSAL INFORMATION PLEASE CONTACT YOUR NEAREST EPA OFFICE.

Benefits

- PetroClear® models 40510D and 40530D are spin-on filters designed to remove particulate in gasoline, ethanol blends, diesel and biodiesel. PetroClear® models 40510D and 40530D sense both free and emulsified water in neat gasoline, diesel and biodiesel. PetroClear® models 40510D and 40530D detect and react to phase separation in Ethanol blended gasoline and slow flow as an indicator to the presence of phase separation.
- PetroClear® model 40510D offers efficient 10 micron (nominal) particulate removal, senses both free and emulsified water and detects and reacts to phase separation.
- PetroClear® model 40530D offers efficient 30 micron (nominal) particulate removal, senses both free and emulsified water and detects and reacts to phase separation.
- The “dual purpose” models provide protection during the transition from neat gasoline to ethanol blends without the need to change filters.
- Textured paint coating helps ensure a simple, mess-free installation and removal process.
- UL® recognized.

PetroClear® Filters are NOT to be used in Aviation Fuel Applications!

Specifications

- The PetroClear® model 40510D utilizes a 10 micron (nominal) cellulose media to remove particulate 10 microns (nominal) or larger from neat gasoline, ethanol blends, diesel and biodiesel. The PetroClear® model 40510D also senses water in neat gasoline, diesel and bio-diesel. The PetroClear® model 40510D provides phase separation detecting capabilities for ethanol-blended gasoline. It utilizes a super absorbent media for sensing water and a chemical core assembly to detect and react to phase separation.
- The PetroClear® model 40530D utilizes a 30 micron (nominal) cellulose media to remove particulate 30 microns (nominal) or larger from neat gasoline, ethanol blends, diesel and biodiesel. The PetroClear® model 40530D also senses water in neat gasoline, diesel and bio-diesel. The PetroClear® model 40530D provides phase separation detecting capabilities for ethanol-blended gasoline. It utilizes a super absorbent media for sensing water and a chemical core assembly to detect and react to phase separation.
- Once PetroClear® models 40510D and 40530D have absorbed 5.9 ounces (175 mil) of water, flow will be noticeably slow.
- The center chemical core assembly detects and reacts to phase separation and significantly restricts flow through filters.
- The maximum flow rate for PetroClear® models 40510D and 40530D is 25 gpm (94.6 lpm). Maximum operating pressure is 50 psid (3.4 bar).
- Collapse pressure is 150 psid (10.3 bar). Maximum operating temperature is 250°F (139°C).
- PetroClear® 40510D and 40530D “Dual Purpose” filters utilize a standard 1" – 12 UNF mounting thread ref. (3/4" flow) required for most spin-on filter Adapters used in Gilbarco, Wayne, Bennett, Tokheim and other major manufacturers’ dispensers, as well as with Adapters used in the aftermarket.
- Adapters are available for models 40510D and 40530D in aluminum and cast iron. These single Adapters are available in both 3/4" and 1" NPT and BSP inlet/outlet threads.

NOTE: If you experience frequent filter changes, it is recommended that you have fuel samples analyzed to determine the source of contamination, such as water, dirt, rust, bacteria, phase separation, etc.

40510D and 40530D “Dual Purpose”

Removes Particulate, Detects Phase Separation & Senses Water

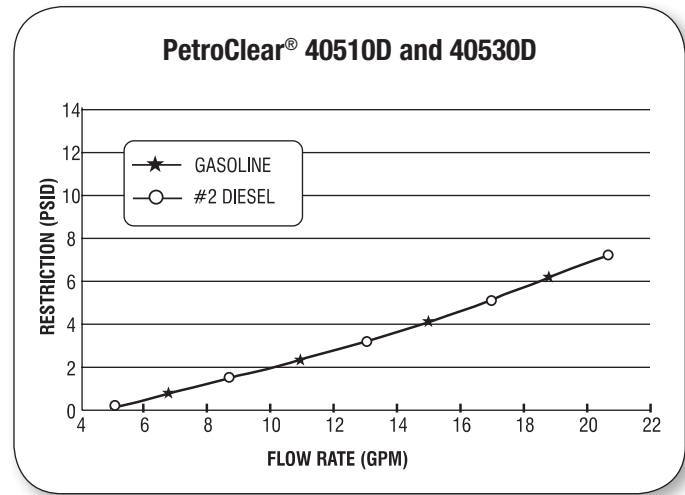
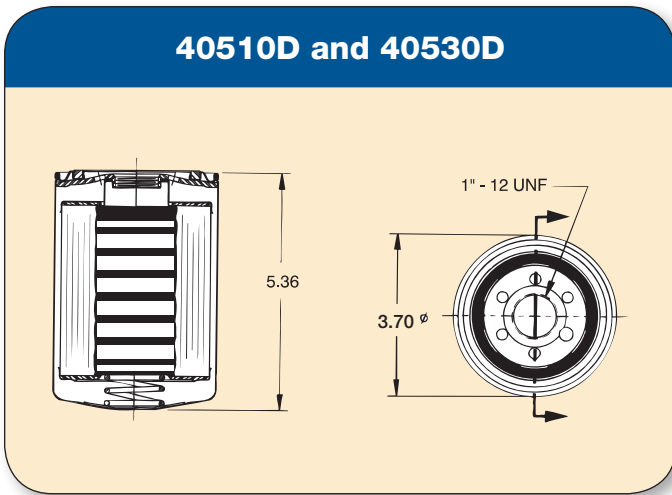

Model	40510D	40530D
Filter Type	Spin-On	Spin-On
Media Type	Cellulose* with Super Absorbent Media** and Chemical Core***	Cellulose* with Super Absorbent Media** and Chemical Core***
Micron Rating	10 Micron (nominal)	30 Micron (nominal)
Diameter	3.70"	3.70"
Height	5.36"	5.36"
Mounting Thread	1" – 12 UNF	1" – 12 UNF
Flow Rate	25 gpm (94.6 lpm)	25 gpm (94.6 lpm)
Flow	3/4" flow	3/4" flow
Shell Thickness	0.020	0.020
Gasket Material	Buna N	Buna N
Collapse (Min.)	150 psid (10.3 bar)	150 psid (10.3 bar)
Burst (Min.)	250 psi (17.2 bar)	250 psi (17.2 bar)
Max. Operating Temp.	250°F (139°C)	250°F (139°C)
Min. Operating Temp.	-20°F (-28.9°C)	-20°F (-28.9°C)

*Particulate Removing, **Water Sensing, ***Detects Phase Separation

Available Adapters

Part/Model Number	Description
.75 N1-12	3/4" NPT Inlet/Outlet Ports, 1" – 12 UNF (cast iron)
.75 N1-12A	3/4" NPT Inlet/Outlet Ports, 1" – 12 UNF (aluminum)
1.00N-12	1" NPT Inlet/Outlet Ports, 1" – 12 UNF (cast iron)
1.00N1-12A	1" NPT Inlet/Outlet Ports, 1" – 12 UNF (aluminum)
.75 B1-12	3/4" BSP Inlet/Outlet Ports, 1" – 12 UNF (aluminum)
1.00B1-12	1" BSP Inlet/Outlet Ports, 1" – 12 UNF (aluminum)

405 D-AD Series “Dual Purpose”

Removes Particulate,
Detects Phase Separation & Senses Water

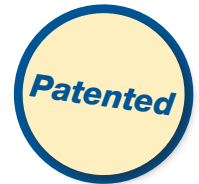

40510D-AD and 40530D-AD

Detects and Reacts to Phase Separation in Ethanol Blends and Senses Water in Gasoline, Diesel and Biodiesel

FOR DISPOSAL INFORMATION PLEASE CONTACT YOUR NEAREST EPA OFFICE.

Benefits

- PetroClear® models 40510D-AD and 40530D-AD are spin-on filters designed to remove particulate in gasoline, ethanol blends, diesel and biodiesel. PetroClear® models 40510D-AD and 40530D-AD sense both free and emulsified water in neat gasoline, diesel and biodiesel. PetroClear® models 40510D-AD and 40530D-AD detect and react to phase separation in Ethanol blended gasoline and slow flow as an indicator to the presence of phase separation.
- PetroClear® model 40510D-AD offers efficient 10 micron (nominal) particulate removal, senses both free and emulsified water and detects and reacts to phase separation.
- PetroClear® model 40530D-AD offers efficient 30 micron (nominal) particulate removal, senses both free and emulsified water and detects and reacts to phase separation.
- The “dual purpose” models provide protection during the transition from neat gasoline to ethanol blends without the need to change filters.
- Textured paint coating helps ensure a simple, mess-free installation and removal process.
- UL® recognized.

PetroClear® Filters are NOT to be used in Aviation Fuel Applications!

Specifications

- The PetroClear® model 40510D-AD utilizes a 10 micron (nominal) cellulose media to remove particulate 10 microns (nominal) or larger from neat gasoline, ethanol blends, diesel and biodiesel. The PetroClear® model 40510D-AD also senses water in neat gasoline, diesel and biodiesel. The PetroClear® model 40510D-AD provides phase separation detecting capabilities for ethanol-blended gasoline. It utilizes a super absorbent media for sensing water and a chemical core assembly to detect and react to phase separation.
- The PetroClear® model 40530D-AD utilizes a 30 micron (nominal) cellulose media to remove particulate 30 microns (nominal) or larger from neat gasoline, ethanol blends, diesel and biodiesel. The PetroClear® model 40530D-AD also senses water in neat gasoline, diesel and biodiesel. The PetroClear® model 40530D-AD provides phase separation detecting capabilities for ethanol-blended gasoline. It utilizes a super absorbent media for sensing water and a chemical core assembly to detect and react to phase separation.
- Once PetroClear® models 40510D-AD and 40530D-AD have absorbed 5.9 ounces (175 mil) of water, flow will be noticeably slow.
- The center chemical core assembly detects and reacts to phase separation and significantly restricts flow through filters.
- The maximum flow rate for PetroClear® models 40510D-AD and 40530D-AD is 25 gpm (94.6 lpm). Maximum operating pressure is 50 psid (3.4 bar).
- Collapse pressure is 150 psid (10.3 bar). Maximum operating temperature is 250°F (139°C).
- PetroClear® models 40510D-AD and 40530D-AD “Dual Purpose” high-flow filters utilize a standard 1.5” – 16 UNF mounting thread ref. (1” flow) required for most spin-on filter adapters used in aftermarket and/or today’s high-flow fuel applications such as in Gilbarco, Wayne, Bennett, Tokheim and other major manufacturers’ dispensers.
- Adapters are available for models 40510D-AD and 40530D-AD in aluminum. These single Adapters are available in both 3/4” and 1” NPT and BSP inlet/outlet threads.

NOTE: If you experience frequent filter changes, it is recommended that you have fuel samples analyzed to determine the source of contamination, such as water, dirt, rust, bacteria, phase separation, etc.

40510D-AD and 40530D-AD “Dual Purpose”

Removes Particulate, Detects Phase Separation & Senses Water

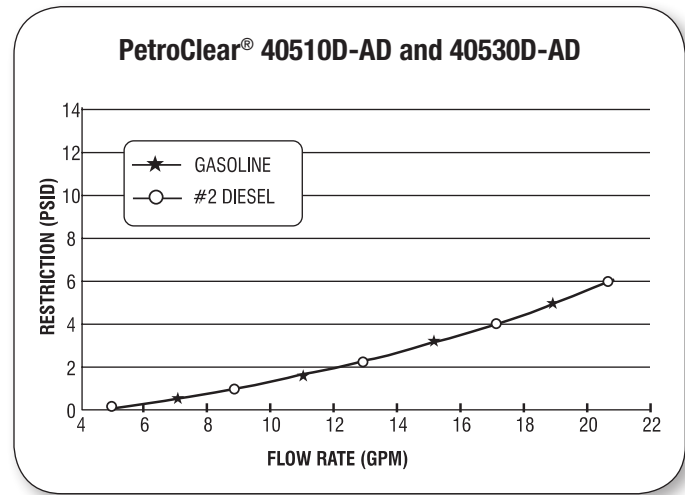
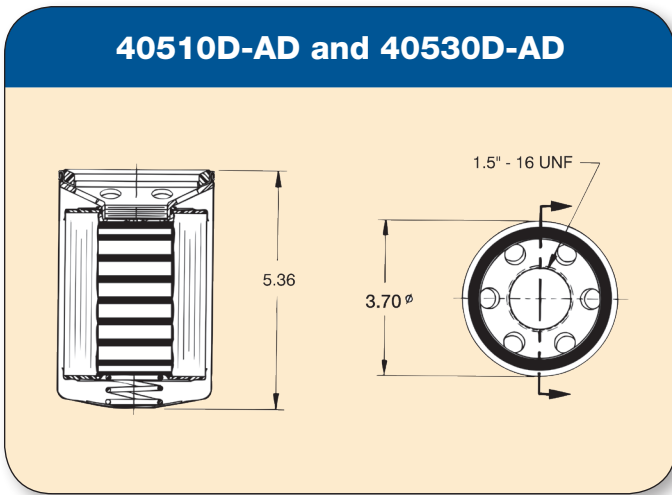

Model	40510D-AD	40530D-AD
Filter Type	Spin-On	Spin-On
Media Type	Cellulose* with Super Absorbent Media** and Chemical Core***	Cellulose* with Super Absorbent Media** and Chemical Core***
Micron Rating	10 Micron (nominal)	30 Micron (nominal)
Diameter	3.70"	3.70"
Height	5.36"	5.36"
Mounting Thread	1.5" – 16 UNF	1.5" – 16 UNF
Flow Rate	25 gpm (94.6 lpm)	25 gpm (94.6 lpm)
Flow	1" flow	1" flow
Shell Thickness	0.020	0.020
Gasket Material	Buna N	Buna N
Collapse (Min.)	150 psid (10.3 bar)	150 psid (10.3 bar)
Burst (Min.)	500 psi (34.5 bar)	500 psi (34.5 bar)
Max. Operating Temp.	250°F (139°C)	250°F (139°C)
Min. Operating Temp.	-20°F (-28.9°C)	-20°F (-28.9°C)

*Particulate Removing, **Water Sensing, ***Detects Phase Separation

Available Adapters

Part/Model Number	Description
.75 N1.5-16AD	3/4" NPT Inlet/Outlet Ports, 1.5" – 16 UNF (aluminum)
1.0 N1.5-16AD	1" NPT Inlet/Outlet Ports, 1.5" – 16 UNF (aluminum)
.75B1.5-16ADA	3/4" BSP Inlet/Outlet Ports, 1"-16 UNF (aluminum)
1.00B1.5-16ADA	1" BSP Inlet/Outlet Ports, 1"-16 UNF (aluminum)

408 Series

Particulate Removing with Drain Valve



40810P-DV and 40830P-DV

With Petcock Type Drain Valve
(Not for Commercial Dispenser Use)

FOR DISPOSAL INFORMATION PLEASE CONTACT YOUR NEAREST EPA OFFICE.

Benefits

- PetroClear® models 40810P-DV and 40830P-DV are particulate removing spin-on filters designed to remove particulate from neat gasoline, Ethanol blended gasolines, diesels, Biodiesel, ULSD (Ultra Low Sulfur Diesel), Kerosene and fuel oils.
- PetroClear® models 40810P-DV and 40830P-DV are particulate spin-on filters. These filters are designed for particulate removal only and will not react to water in gasoline or diesel fuel nor to phase separation in alcohol blended gasolines by slowing flow.
- PetroClear® model 40810P-DV filter offers efficient 10 micron (nominal) particulate removal.
- PetroClear® model 40830P-DV filter offers efficient 30 micron (nominal) particulate removal.
- Compatible with neat gasoline Ethanol blended fuels and diesels including Biodiesel.
- Not approved for use on retail fuel dispensers.

PetroClear® Filters are NOT to be used in Aviation Fuel Applications!

Specifications

- The PetroClear® model 40810P-DV utilizes a 10 micron (nominal) cellulose media to remove particulate from gasolines and diesel fuels including Ethanol blended gasoline, Biodiesel and ULSD (Ultra Low Sulfur Diesel). Removes particulate 10 microns (nominal) or larger.
- The PetroClear® model 40830P-DV utilizes a 30 micron (nominal) cellulose media to remove particulate from gasolines and diesel fuels including Ethanol blended gasoline, Biodiesel and ULSD (Ultra Low Sulfur Diesel). Removes particulate 30 microns (nominal) or larger.
- The maximum flow rate for PetroClear® models 40810P-DV and 40830P-DV is 25 gpm (94.6 lpm). Maximum operating pressure is 50 psid (3.4 bar). Collapse pressure is 150 psid (10.3 bar). Maximum operating temperature is 250°F (139°C).
- PetroClear® models 40810P-DV and 40830P-DV utilize a standard 1"-12 UNF mounting thread ref. (3/4" flow) required for most spin-on filter Adapters used in aftermarket.
- Models 40810P-DV and 40830P-DV utilize a silicone treated media that repels water from fuel and prevents the water from passing through the filter into consumers' vehicles. The water settles to the dome end of PetroClear® models 40810P-DV and 40830P-DV. A petcock type drain valve located in the bottom of the filters permits convenient drainage of collected water.
- Adapters are available for models 40810P-DV and 40830P-DV in aluminum and cast iron. These Adapters are available in both NPT and BSP inlet/outlet threads. Inlet/outlet sizes are available in 3/4" and 1" single Adapters.

NOTE: If you experience frequent filter changes, it is recommended that you have fuel samples analyzed to determine the source of contamination, such as water, dirt, rust, bacteria, phase separation, etc.

40810P-DV and 40830P-DV

With Petcock Type Drain Valve

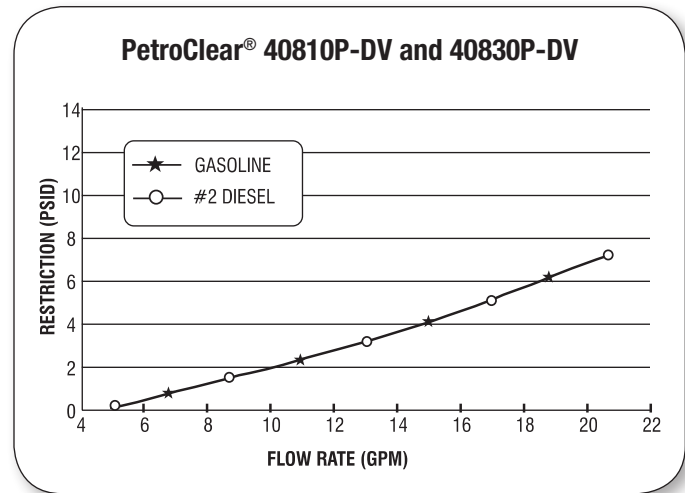
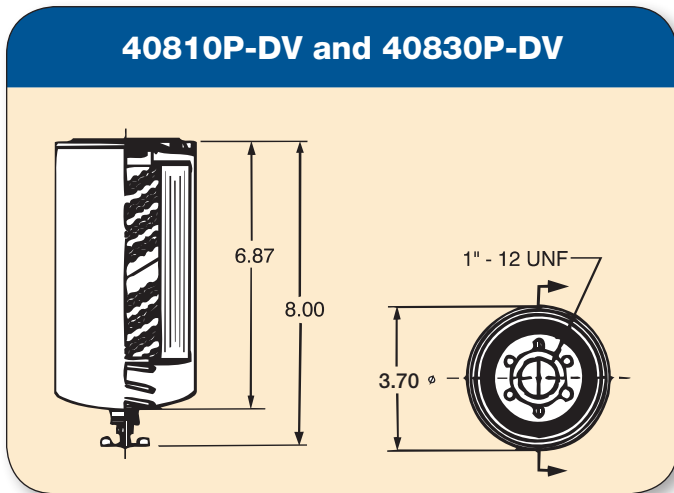

Model	40810P-DV	40830P-DV
Filter Type	Spin-On	Spin-On
Media Type	*Cellulose with Silicone Treatment	*Cellulose with Silicone Treatment
Micron Rating	10 Micron (nominal)	30 Micron (nominal)
Diameter	3.70"	3.70"
Height	6.87"	6.87"
Mounting Thread	1" - 12 UNF	1" - 12 UNF
Flow Rate	25 gpm (94.6 lpm)	25 gpm (94.6 lpm)
Flow	3/4" flow	3/4" flow
Shell Thickness	0.020	0.020
Gasket Material	Buna N	Buna N
Collapse (Min.)	150 psid (10.3 bar)	150 psid (10.3 bar)
Burst (Min.)	250 psi (17.2 bar)	250 psi (17.2 bar)
Max. Operating Temp.	250°F (139°C)	250°F (139°C)

*Silicone Treated & Particulate Removing

Available Adapters

Part/Model Number	Description
.75 N1-12	3/4" NPT Inlet/Outlet Ports, 1" - 12 UNF (cast iron)
.75 N1-12A	3/4" NPT Inlet/Outlet Ports, 1" - 12 UNF (aluminum)
1.00N-12	1" NPT Inlet/Outlet Ports, 1" - 12 UNF (cast iron)
1.00N1-12A	1" NPT Inlet/Outlet Ports, 1" - 12 UNF (aluminum)
.75 B1-12	3/4" BSP Inlet/Outlet Ports, 1" - 12 UNF (aluminum)
1.00B1-12	1" BSP Inlet/Outlet Ports, 1" - 12 UNF (aluminum)

409 Series

Particulate Removing



40910P and 40930P
Extended Life Particulate
(For Dispenser Use)

FOR DISPOSAL INFORMATION PLEASE CONTACT YOUR NEAREST EPA OFFICE.

Benefits

- PetroClear® models 40910P and 40930P are particulate removing spin-on filters designed to remove particulate from neat gasoline, Ethanol blended gasolines, diesels, Biodiesel, ULSD (Ultra Low Sulfur Diesel), kerosene and fuel oils.
- PetroClear® models 40910P and 40930P are particulate spin-on filters. These filters are designed for particulate removal only and WILL NOT REACT TO WATER IN NEAT GASOLINE OR DETECT PHASE SEPARATION IN ETHANOL BLENDED GASOLINES TO SLOW FLOW.
- PetroClear® model 40910P filter offers efficient 10 micron (nominal) particulate removal.
- PetroClear® model 40930P filter offers efficient 30 micron (nominal) particulate removal.
- Textured paint coating helps ensure a simple, mess-free installation and removal process.
- UL® recognized
- Compatible with neat gasoline, Diesels, Biodiesel and Ethanol blended fuels.

PetroClear® Filters are NOT to be used in Aviation Fuel Applications!

Specifications

- The PetroClear® model 40910P utilizes a 10 micron (nominal) cellulose media to remove particulate from gasoline and diesel fuels including Ethanol blended gasoline, Biodiesel and ULSD (Ultra Low Sulfur Diesel). Removes particulate 10 microns (nominal) or larger.
- The PetroClear® model 40930P utilizes a 30 micron (nominal) cellulose media to remove particulate from gasoline and diesel fuels including Ethanol blended gasoline, Biodiesel and ULSD (Ultra Low Sulfur Diesel). Removes particulate 30 microns (nominal) or larger.
- The maximum flow rate for PetroClear® models 40910P and 40930P is 25 gpm (94.6 lpm). Maximum operating pressure is 50 psid (3.4 bar). Collapse pressure is 150 psid (10.3 bar). Maximum operating temperature is 250°F (139°C).
- PetroClear® models 40910P and 40930P utilize a standard 1" – 12 UNF mounting thread ref. (3/4" flow) required for most spin-on filter Adapters used in Gilbarco, Wayne, Bennet, Tokheim and other major manufacturers' dispensers, as well as with Adapters used in the aftermarket.
- Adapters are available for models 40910P and 40930P in aluminum and cast iron. Single Adapters are available in both 3/4" and 1" NPT and BSP inlet/outlet threads.

NOTE: If you experience frequent filter changes, it is recommended that you have fuel samples analyzed to determine the source of contamination, such as water, dirt, rust, bacteria, phase separation, etc.

40910P and 40930P

For Fuel Dispensers

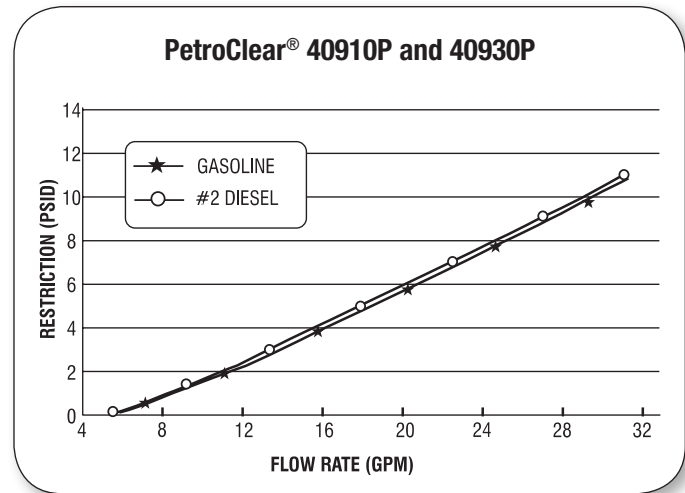
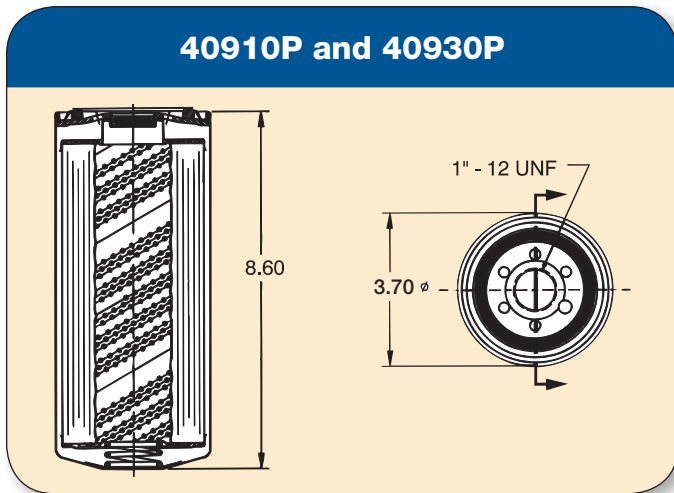

Model	40910P	40930P
Filter Type	Spin-On	Spin-On
Media Type	*Cellulose	*Cellulose
Micron Rating	10 Micron (nominal)	30 Micron (nominal)
Diameter	3.70"	3.70"
Height	8.60"	8.60"
Mounting Thread	1" - 12 UNF	1" - 12 UNF
Flow Rate	25 gpm (94.6 lpm)	25 gpm (94.6 lpm)
Flow	3/4" flow	3/4" flow
Shell Thickness	0.020	0.020
Gasket Material	Buna N	Buna N
Collapse (Min.)	150 psid (10.3 bar)	150 psid (10.3 bar)
Burst (Min.)	250 psi (17.2 bar)	250 psi (17.2 bar)
Max. Operating Temp.	250°F (139°C)	250°F (139°C)

*Particulate Removing

Available Adapters

Part/Model Number	Description
.75 N1-12	3/4" NPT Inlet/Outlet Ports, 1" - 12 UNF (cast iron)
.75 N1-12A	3/4" NPT Inlet/Outlet Ports, 1" - 12 UNF (aluminum)
1.00N-12	1" NPT Inlet/Outlet Ports, 1" - 12 UNF (cast iron)
1.00N1-12A	1" NPT Inlet/Outlet Ports, 1" - 12 UNF (aluminum)
.75 B1-12	3/4" BSP Inlet/Outlet Ports, 1" - 12 UNF (aluminum)
1.00B1-12	1" BSP Inlet/Outlet Ports, 1" - 12 UNF (aluminum)

409 Series

Agricultural Application Particulate Removing



40910PA and 40930PA

Extended Life
Agricultural Particulate Removal

FOR DISPOSAL INFORMATION PLEASE CONTACT YOUR NEAREST EPA OFFICE.

Benefits

- PetroClear® models 40910PA and 40930PA are particulate removing spin-on filters designed to remove particulate from gasoline, diesel, Biodiesel, ULSD (Ultra Low Sulfur Diesel), Kerosene and fuel oils.
- The 40910PA and 40930PA are designed to remove particulate from gasoline, Ethanol blended gasoline, diesel, Biodiesel, ULSD (Ultra Low Sulfur Diesel), Kerosene and fuel oils.
- PetroClear® models 40910PA and 40930PA are particulate spin-on filters. These filters are designed for particulate removal only and WILL NOT REACT TO WATER IN NEAT GASOLINE OR DETECT PHASE SEPARATION IN ETHANOL BLENDED GASOLINE.
- PetroClear® model 40910PA filter offers efficient 10 micron (nominal) particulate removal.
- PetroClear® model 40930PA filter offers efficient 30 micron (nominal) particulate removal.
- Compatible with Biodiesel, Kerosene, Fuel Oil, ULSD (Ultra Low Sulfur Diesel), and Diesel fuels and Ethanol blended fuels.

PetroClear® Filters are NOT to be used in Aviation Fuel Applications!

Specifications

- The PetroClear® model 40910PA utilizes a 10 micron (nominal) cellulose media to remove particulate from gasolines and diesel fuels including Ethanol blended gasoline, Biodiesel and ULSD (Ultra Low Sulfur Diesel). Removes particulate 10 microns (nominal) or larger.
- The PetroClear® model 40930PA utilizes a 30 micron (nominal) cellulose media to remove particulate from gasolines and diesel fuels including Ethanol blended gasoline, Biodiesel and ULSD (Ultra Low Sulfur Diesel). Removes particulate 30 microns (nominal) or larger.
- The maximum flow rate for PetroClear® models 40910PA and 40930PA is 25 gpm (94.6 lpm). Maximum operating pressure is 50 psid (3.4 bar). Collapse pressure is 150 psid (10.3 bar). Maximum operating temperature is 250°F (139°C).
- PetroClear® models 40910PA and 40930PA utilize a standard 1.375"-12 UNF mounting thread ref. (1" flow) required for most spin-on filter adapters used in aftermarket and agricultural applications.
- PetroClear® models 40910PA and 40930PA utilize an epoxy coated interior shell to eliminate oxidation (rusting), which can cause pinhole leaks from the inside of the filter shell.
- Adapters are available for models 40910PA and 40930PA in cast iron. These single adapters are available in 1" NPT inlet/outlet threads.

NOTE: If you experience frequent filter changes, it is recommended that you have fuel samples analyzed to determine the source of contamination, such as water, dirt, rust, bacteria, phase separation, etc.

40910PA and 40930PA

Agricultural

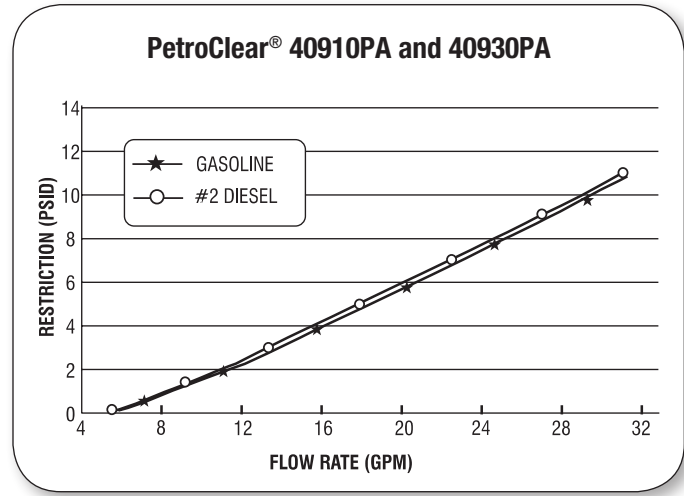
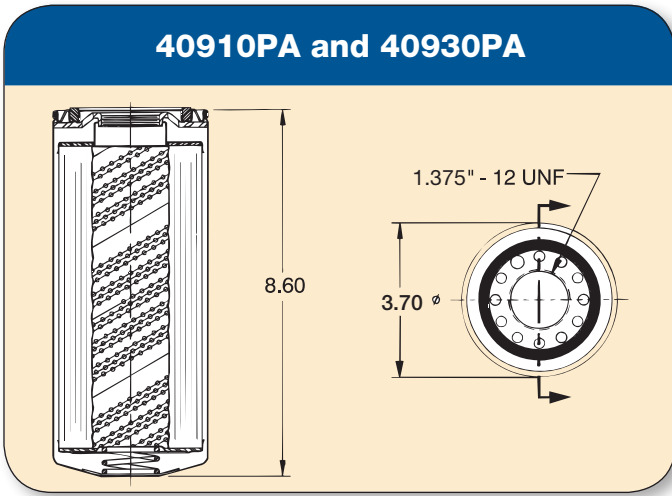

Model	40910PA	40930PA
Filter Type	Spin-On	Spin-On
Media Type	*Cellulose	*Cellulose
Micron Rating	10 Micron (nominal)	30 Micron (nominal)
Diameter	3.70"	3.70"
Height	8.60"	8.60"
Mounting Thread	1.375" - 12 UNF	1.375" - 12 UNF
Flow Rate	25 gpm (94.6 lpm)	25 gpm (94.6 lpm)
Flow	1" flow	1" flow
Shell Thickness	0.020	0.020
Gasket Material	Buna N	Buna N
Collapse (Min.)	150 psid (10.3 bar)	150 psid (10.3 bar)
Burst (Min.)	250 psi (17.2 bar)	250 psi (17.2 bar)
Max. Operating Temp.	250°F (139°C)	250°F (139°C)

*Particulate Removing

Available Adapters

Part/Model Number	Description
1.00N13/8-12	1" NPT Inlet/Outlet Ports, 1.375" -12 UNF (cast iron)

409-AD Series

Particulate Removing



40910P-AD and 40930P-AD

Extended Life Particulate
For High-Flow Fuel Dispensers

FOR DISPOSAL INFORMATION PLEASE CONTACT YOUR NEAREST EPA OFFICE.

Benefits

- The 40910P-AD and 40930P-AD are designed to remove particulate from gasoline, Ethanol blended gasolines, diesels, Biodiesel, ULSD (Ultra Low Sulfur Diesel), Kerosene and fuel oils.
- PetroClear® models 40910P-AD and 40930P-AD are particulate spin-on filters. These filters are designed for particulate removal only and WILL NOT REACT TO WATER IN NEAT GASOLINE OR DETECT PHASE SEPARATION IN ETHANOL BLENDED GASOLINE TO SLOW FLOW.
- PetroClear® model 40910P-AD filter offers efficient 10 micron (nominal) particulate removal.
- PetroClear® model 40930P-AD filter offers efficient 30 micron (nominal) particulate removal.
- Textured paint coating helps ensure a simple, mess-free installation and removal process.
- UL® recognized
- Compatible with neat gasoline, Ethanol blended fuels and all diesels including Biodiesels.

PetroClear® Filters are NOT to be used in Aviation Fuel Applications!

Specifications

- The PetroClear® model 40910P-AD utilizes a 10 micron (nominal) cellulose media to remove particulate from gasolines and diesel fuels including Ethanol blended gasoline, Biodiesel and ULSD (Ultra Low Sulfur Diesel). Removes particulate 10 microns (nominal) or larger.
- The PetroClear® model 40930P-AD utilizes a 30 micron (nominal) cellulose media to remove particulate from gasolines and diesel fuels including Ethanol blended gasoline, Biodiesel and ULSD (Ultra Low Sulfur Diesel). Removes particulate 30 microns (nominal) or larger.
- The maximum flow rate for PetroClear® models 40910P-AD and 40930P-AD is 25 gpm (94.6 lpm). Maximum operating pressure is 50 psid (3.4 bar). Collapse pressure is 150 psid (10.3 bar). Maximum operating temperature is 250°F (139°C).
- PetroClear® models 40910P-AD and 40930P-AD utilize a standard 1.5"-16 UNF mounting thread ref. (1" flow) required for most spin-on filter Adapters used in aftermarket and/or high-flow applications, such as in Gilbarco, Wayne, Bennet, Tokheim and other major manufacturers' dispensers.
- Adapters are available for models 40910P-AD and 40930P-AD in aluminum. These single Adapters are available in 3/4" and 1" NPT and BSP inlet/outlet threads.

NOTE: If you experience frequent filter changes, it is recommended that you have fuel samples analyzed to determine the source of contamination, such as water, dirt, rust, bacteria, phase separation, etc.

40910P-AD and 40930P-AD

Extended Life for High-Flow Fuel Dispensers

40910P-AD and 40930P-AD

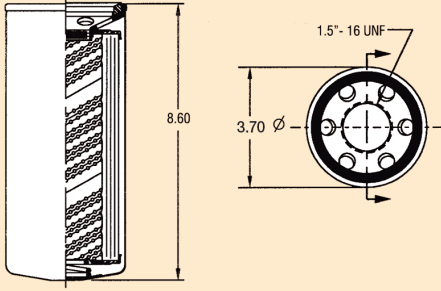

PetroClear® 40910P-AD and 40930P-AD

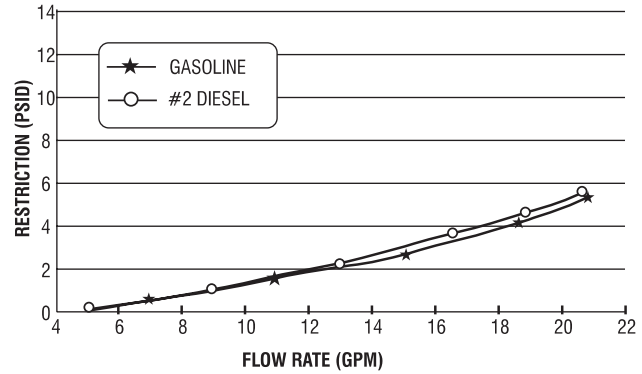

Model	40910P-AD	40930P-AD
Filter Type	Spin-On	Spin-On
Media Type	*Cellulose	*Cellulose
Micron Rating	10 Micron (nominal)	30 Micron (nominal)
Diameter	3.70"	3.70"
Height	8.60"	8.60"
Mounting Thread	1.5" – 16 UNF	1.5" – 16 UNF
Flow Rate	25 gpm (94.6 lpm)	25 gpm (94.6 lpm)
Flow	1" flow	1" flow
Shell Thickness	0.020	0.020
Gasket Material	Buna N	Buna N
Collapse (Min.)	150 psid (10.3 bar)	150 psid (10.3 bar)
Burst (Min.)	500 psi (34.5 bar)	500 psi (34.5 bar)
Max. Operating Temp.	250°F (139°C)	250°F (139°C)

*Particulate Removing

Available Adapters

Part/Model Number	Description
.75 N1.5-16AD	3/4" NPT Inlet/Outlet Ports, 1.5" – 16 UNF (aluminum)
1.0 N1.5-16AD	1" NPT Inlet/Outlet Ports, 1.5" – 16 UNF (aluminum)
.75B1.5-16ADA	3/4" BSP Inlet/Outlet Ports, 1"-16 UNF (aluminum)
1.00B1.5-16ADA	1" BSP Inlet/Outlet Ports, 1"-16 UNF (aluminum)

409 Series

Water Sensing & Particulate Removing



40910W and 40930W
Extended Life Water Sensing
For Dispenser Use

FOR DISPOSAL INFORMATION PLEASE CONTACT YOUR NEAREST EPA OFFICE.

Benefits

- The 40910W and 40930W are designed to remove particulate and to sense both free and emulsified water from neat gasoline, diesel, Biodiesel, ULSD (Ultra Low Sulfur Diesel), Kerosene, and fuel oils. This filter will not sense nor react to water in Ethanol-blended gasoline. (Reaction known as phase separation)
- PetroClear® models 40910W and 40930W are particulate and water sensing spin-on filters. These filters are designed to sense water, both free and emulsified, and slow flow as an indicator of the presence of water in neat gasoline and diesel fuels.
- PetroClear® model 40910W filter offers efficient 10 micron (nominal) particulate removal and senses both free and emulsified water in neat gasoline and diesel fuels.
- PetroClear® model 40930W filter offers efficient 30 micron (nominal) particulate removal and senses both free and emulsified water in neat gasoline and diesel fuels.
- Textured paint coating helps ensure a simple, mess-free installation and removal process.
- UL® recognized
- Will not detect phase separation in Ethanol blended fuels.

PetroClear® Filters are NOT to be used in Aviation Fuel Applications!

Specifications

- The PetroClear® model 40910W utilizes a 10 micron (nominal) cellulose media to remove particulate from gasoline and diesel fuels including Biodiesel and ULSD (Ultra Low Sulfur Diesel). Removes particulate 10 microns (nominal) or larger, with water sensing capability in neat gasoline and diesel fuels.
- The PetroClear® model 40930W utilizes a 30 micron (nominal) cellulose media to remove particulate from gasoline and diesel fuels including Biodiesel and ULSD (Ultra Low Sulfur Diesel). Removes particulate 30 microns (nominal) or larger, with water sensing capability in neat gasoline and diesel fuels.
- Once PetroClear® models 40910W and 40930W have absorbed 10.7 ounces (315 mil) of water from neat gasoline or diesel fuel, flow will be noticeably slow.
- The maximum flow rate for PetroClear® models 40910W and 40930W is 25 gpm (94.6 lpm). Maximum operating pressure is 50 psid (3.4 bar). Collapse pressure is 150 psid (10.3 bar). Maximum operating temperature is 250°F (139°C).
- PetroClear® models 40910W and 40930W utilize a standard 1"-12 UNF mounting thread ref. (3/4" flow) required for most spin-on filter Adapters used in Gilbarco, Wayne, Bennet, Tokheim and other major manufacturers' dispensers, as well as with Adapters used in the aftermarket.
- Adapters are available for models 40910W and 40930W in aluminum and cast iron. These single Adapters are available in both 3/4" and 1" NPT or BSP inlet/outlet threads.

NOTE: If you experience frequent filter changes, it is recommended that you have fuel samples analyzed to determine the source of contamination, such as water, dirt, rust, bacteria, phase separation, etc.

40910W and 40930W

For Fuel Dispensers

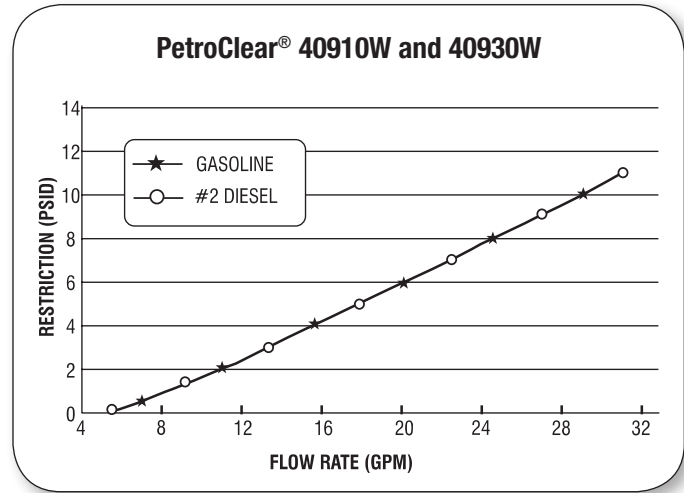
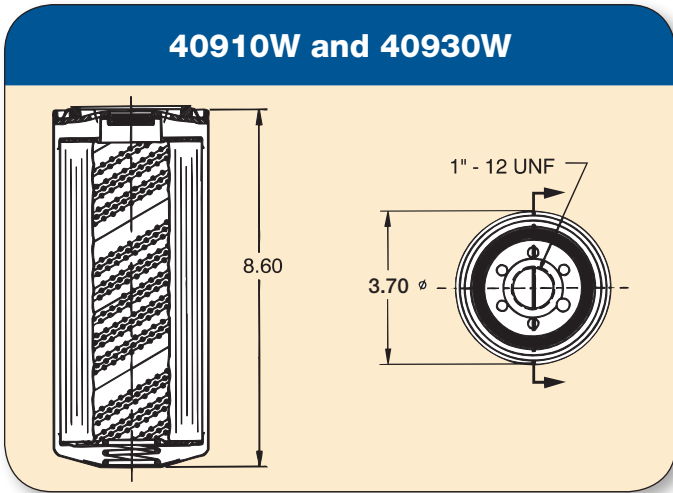

Model	40910W	40930W
Filter Type	Spin-On	Spin-On
Media Type	*Cellulose with Super Absorbent Media	*Cellulose with Super Absorbent Media
Micron Rating	10 Micron (nominal)	30 Micron (nominal)
Diameter	3.70"	3.70"
Height	8.60"	8.60"
Mounting Thread	1" – 12 UNF	1" – 12 UNF
Flow Rate	25 gpm (94.6 lpm)	25 gpm (94.6 lpm)
Flow	3/4" flow	3/4" flow
Shell Thickness	0.020	0.020
Gasket Material	Buna N	Buna N
Collapse (Min.)	150 psid (10.3 bar)	150 psid (10.3 bar)
Burst (Min.)	250 psi (17.2 bar)	250 psi (17.2 bar)
Max. Operating Temp.	250°F (139°C)	250°F (139°C)

*Water Sensing & Particulate Removing

Available Adapters

Part/Model Number	Description
.75 N1-12	3/4" NPT Inlet/Outlet Ports, 1" – 12 UNF (cast iron)
.75 N1-12A	3/4" NPT Inlet/Outlet Ports, 1" – 12 UNF (aluminum)
1.00N-12	1" NPT Inlet/Outlet Ports, 1" – 12 UNF (cast iron)
1.00N1-12A	1" NPT Inlet/Outlet Ports, 1" – 12 UNF (aluminum)
.75 B1-12	3/4" BSP Inlet/Outlet Ports, 1" – 12 UNF (aluminum)
1.00B1-12	1" BSP Inlet/Outlet Ports, 1" – 12 UNF (aluminum)

409-AD Series

Water Sensing & Particulate Removing



40910W-AD and 40930W-AD

Extended Life For High-Flow
Fuel Dispensers

FOR DISPOSAL INFORMATION PLEASE CONTACT YOUR NEAREST EPA OFFICE.

Benefits

- The 40910W-AD and 40930W-AD are designed to remove particulate and to sense both free and emulsified water from neat gasoline, diesel, Biodiesel, ULSD (Ultra Low Sulfur Diesel), Kerosene, fuel oils. This filter will not react to phase separation in alcohol blended gasolines by slowing flow.
- PetroClear® models 40910W-AD and 40930W-AD are particulate and water sensing spin-on filters. These filters are designed to sense water, both free and emulsified, and slow flow as an indicator of the presence of water in neat gasoline and Diesel fuels.
- PetroClear® model 40910W-AD filter offers efficient 10 micron (nominal) particulate removal and senses both free and emulsified water from neat gasoline or diesel fuel.
- PetroClear® model 40930W-AD filter offers efficient 30 micron (nominal) particulate removal and senses both free and emulsified water in neat gasoline and diesel fuels.
- Textured paint coating helps ensure a simple, mess-free installation and removal process.
- UL® recognized
- Will not detect phase separation in Ethanol blended fuels.

PetroClear® Filters are NOT to be used in Aviation Fuel Applications!

Specifications

- The PetroClear® model 40910W-AD utilizes a 10 micron (nominal) cellulose media to remove particulate from gasoline and diesel fuels including Biodiesel and ULSD (Ultra Low Sulfur Diesel). Removes particulate 10 microns (nominal) or larger, with water sensing capability in neat gasoline and diesel fuel.
- The PetroClear® model 40930W-AD utilizes a 30 micron (nominal) cellulose media to remove particulate from gasoline and diesel fuels including Biodiesel and ULSD (Ultra Low Sulfur Diesel). Removes particulate 30 microns (nominal) or larger, with water sensing capability in neat gasoline and diesel fuel.
- Once PetroClear® models 40910W-AD and 40930W-AD have absorbed 10.7 ounces (315 mil) of water from neat gasoline or diesel fuel, flow will be noticeably slow.
- The maximum flow rate for PetroClear® models 40910W-AD and 40930W-AD is 25 gpm (94.6 lpm). Maximum operating pressure is 50 psid (3.4 bar). Collapse pressure is 150 psid (10.3 bar). Maximum operating temperature is 250°F (139°C).
- PetroClear® models 40910W-AD and 40930W-AD utilize a standard 1.5" – 16 UNF mounting thread ref. (1" flow) required for most spin-on filter Adapters used in aftermarket and/or high-flow applications such as in Gilbarco, Wayne, Bennet, Tokheim and other major manufacturers' dispensers.
- Adapters are available for models 40910W-AD and 40930W-AD in aluminum. These single Adapters are available in 3/4" and 1" NPT and BSP inlet/outlet threads.

NOTE: If you experience frequent filter changes, it is recommended that you have fuel samples analyzed to determine the source of contamination, such as water, dirt, rust, bacteria, phase separation, etc.

409-AD Series

Water Sensing & Particulate Removing

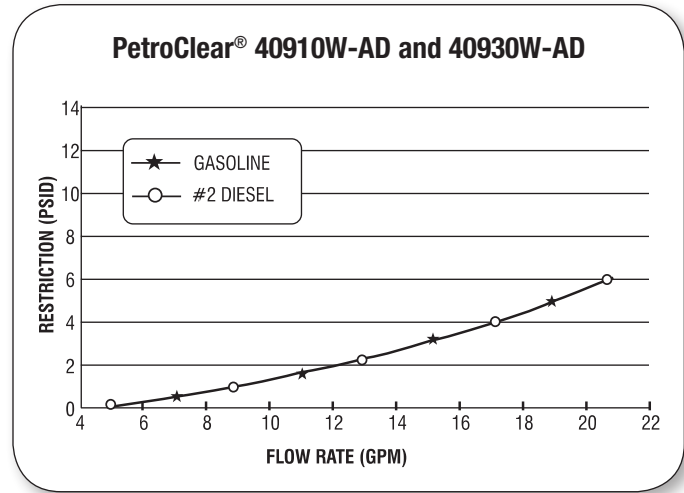
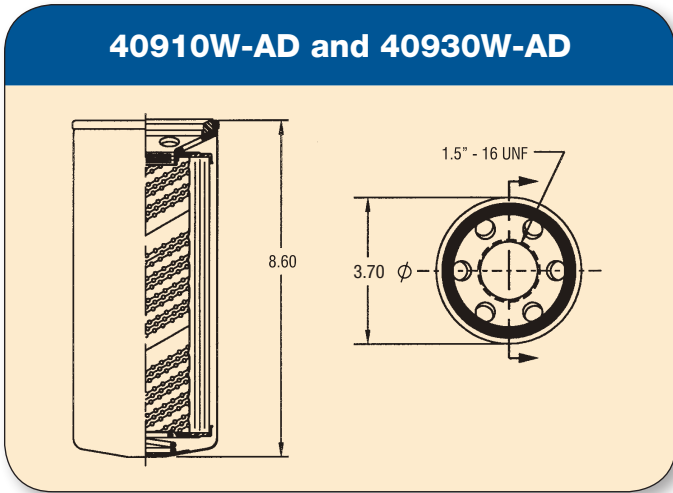

Model	40910W-AD	40930W-AD
Filter Type	Spin-On	Spin-On
Media Type	*Cellulose with Super Absorbent Media	*Cellulose with Super Absorbent Media
Micron Rating	10 Micron (nominal)	30 Micron (nominal)
Diameter	3.70"	3.70"
Height	8.60"	8.60"
Mounting Thread	1.5" – 16 UNF	1.5" – 16 UNF
Flow Rate	25 gpm (94.6 lpm)	25 gpm (94.6 lpm)
Flow	1" flow	1" flow
Shell Thickness	0.020	0.020
Gasket Material	Buna N	Buna N
Collapse (Min.)	150 psid (10.3 bar)	150 psid (10.3 bar)
Burst (Min.)	500 psi (34.5 bar)	500 psi (34.5 bar)
Max. Operating Temp.	250°F (139°C)	250°F (139°C)

*Water Sensing & Particulate Removing

Available Adapters

Part/Model Number	Description
.75 N1.5-16AD	3/4" NPT Inlet/Outlet Ports, 1.5" – 16 UNF (aluminum)
1.0 N1.5-16AD	1" NPT Inlet/Outlet Ports, 1.5" – 16 UNF (aluminum)
.75B1.5-16ADA	3/4" BSP Inlet/Outlet Ports, 1"-16 UNF (aluminum)
1.00B1.5-16ADA	1" BSP Inlet/Outlet Ports, 1"-16 UNF (aluminum)

411 Series “Alert”

Particulate Removal and Phase Separation Detection In Alcohol Blended Fuels

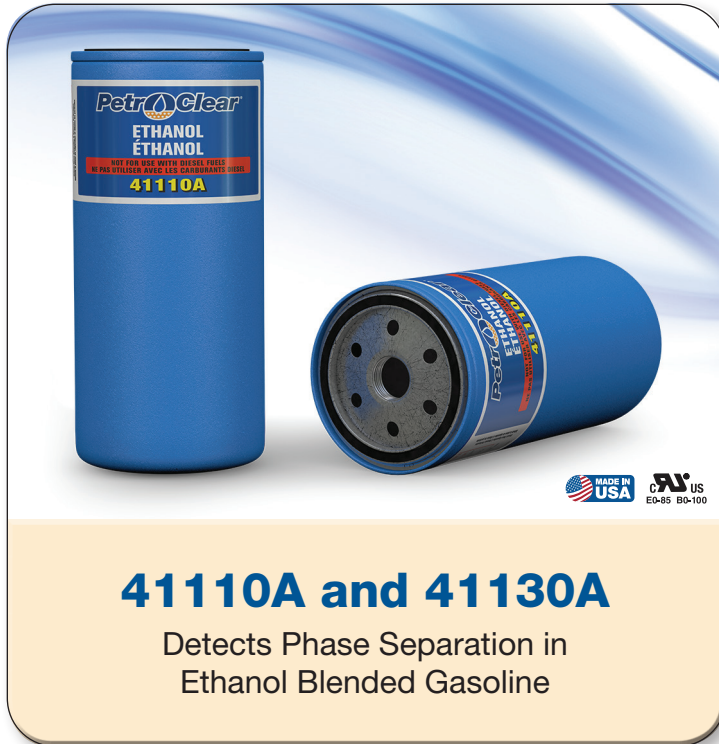

41110A and 41130A

Detects Phase Separation in
Ethanol Blended Gasoline

FOR DISPOSAL INFORMATION PLEASE CONTACT YOUR NEAREST EPA OFFICE.

Benefits

- The “Alert” models 41110A and 41130A are designed to remove particulate and to detect and react to phase separation in Ethanol blended gasoline and slow flow as an indicator to the presence of phase separation. IT WILL NOT SENSE NOR REACT TO WATER IN NON-ALCOHOL BLENDED GASOLINE (NEAT GASOLINE).
- PetroClear® model 41110A filter offers efficient 10 micron (nominal) particulate removal and detects phase separation.
- PetroClear® model 41130A filter offers efficient 30 micron (nominal) particulate removal and detects phase separation.
- Textured paint coating helps ensure a simple, mess-free installation and removal process.
- UL® recognized

PetroClear® Filters are NOT to be used in Aviation Fuel Applications!

Specifications

- The PetroClear® model 41110A utilizes a 10 micron (nominal) cellulose media to remove particulate from Ethanol blended gasoline. Removes particulate 10 microns (nominal) or larger.
- The PetroClear® model 41130A utilizes a 30 micron (nominal) cellulose media to remove particulate from Ethanol blended gasoline. Removes particulate 30 microns (nominal) or larger.
- The “Alert” models 41110A and 41130A are designed to detect and react to phase separation in Ethanol blended gasoline.
- The maximum flow rate for PetroClear® models 41110A and 41130A is 25 gpm (94.6 lpm). Maximum operating pressure is 50 psid (3.4 bar). Collapse pressure is 150 psid (10.3 bar). Maximum operating temperature is 250°F (139°C).
- The chemical center core assembly detects and reacts to phase separation and significantly restricts flow through filters.
- PetroClear® models 41110A and 41130A utilize a standard 1"-12 UNF mounting thread ref. (3/4" flow) required for most spin-on filter adapters used in aftermarket.
- Adapters are available for models 41110A and 41130A in aluminum and cast iron. These single adapters are available in both 3/4" and 1" NPT or BSP inlet/outlet threads.

NOTE: If you experience frequent filter changes, it is recommended that you have fuel samples analyzed to determine the source of contamination, such as water, dirt, rust, bacteria, phase separation, etc.

41110A and 41130A Series the “Alert” Detects Phase Separation

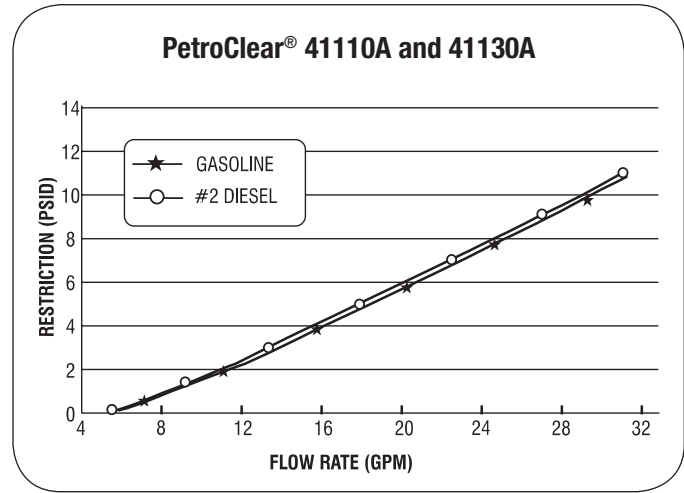
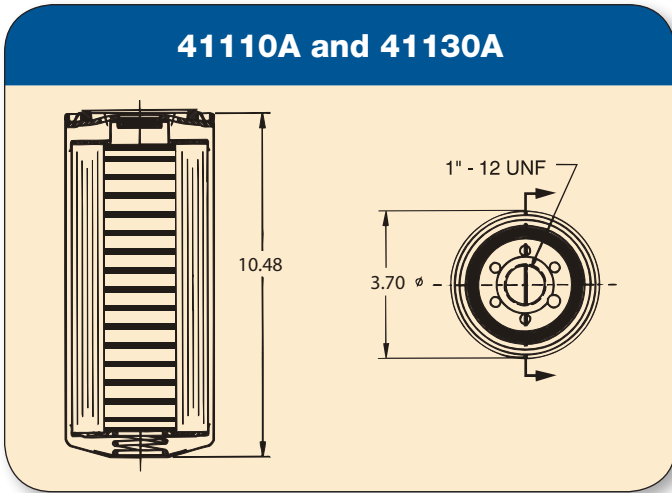

Model	41110A	41130A
Filter Type	Spin-On	Spin-On
Media Type	*Cellulose with Chemical Core	*Cellulose with Chemical Core
Micron Rating	10 Micron (nominal)	30 Micron (nominal)
Diameter	3.70"	3.70"
Height	10.48"	10.48"
Mounting Thread	1" – 12 UNF	1" – 12 UNF
Flow Rate	25 gpm (94.6 lpm)	25 gpm (94.6 lpm)
Flow	3/4" flow	3/4" flow
Shell Thickness	0.020	0.020
Gasket Material	Buna N	Buna N
Collapse (Min.)	150 psid (10.3 bar)	150 psid (10.3 bar)
Burst (Min.)	250 psi (17.2 bar)	250 psi (17.2 bar)
Max. Operating Temp.	250°F (139°C)	250°F (139°C)
Min. Operating Temp.	-20°F (-28.9°C)	-20°F (-28.9°C)

*Particulate Removing and Chemical Core Detects Phase Separation

Available Adapters

Part/Model Number	Description
.75 N1-12	3/4" NPT Inlet/Outlet Ports, 1" – 12 UNF (cast iron)
.75 N1-12A	3/4" NPT Inlet/Outlet Ports, 1" – 12 UNF (aluminum)
1.00N-12	1" NPT Inlet/Outlet Ports, 1" – 12 UNF (cast iron)
1.00N1-12A	1" NPT Inlet/Outlet Ports, 1" – 12 UNF (aluminum)
.75 B1-12	3/4" BSP Inlet/Outlet Ports, 1" – 12 UNF (aluminum)
1.00B1-12	1" BSP Inlet/Outlet Ports, 1" – 12 UNF (aluminum)

411 Series

Particulate Removing



41110P and 41130P
Extended Life Particulate
(For Dispenser Use)

FOR DISPOSAL INFORMATION PLEASE CONTACT YOUR NEAREST EPA OFFICE.

Benefits

- PetroClear® models 41110P and 41130P are particulate removing spin-on filters designed to remove particulate from neat gasoline, Ethanol blended gasolines, diesels, Biodiesel, ULSD (Ultra Low Sulfur Diesel), kerosene and fuel oils.
- PetroClear® models 41110P and 41130P are particulate spin-on filters. These filters are designed for particulate removal only and WILL NOT REACT TO WATER IN NEAT GASOLINE OR DETECT PHASE SEPARATION IN ETHANOL BLENDED GASOLINES TO SLOW FLOW.
- PetroClear® model 41110P filter offers efficient 10 micron (nominal) particulate removal.
- PetroClear® model 41130P filter offers efficient 30 micron (nominal) particulate removal.
- Textured paint coating helps ensure a simple, mess-free installation and removal process.
- UL® recognized
- Compatible with neat gasoline, Diesels, Biodiesel and Ethanol blended fuels.

PetroClear® Filters are NOT to be used in Aviation Fuel Applications!

Specifications

- The PetroClear® model 41110P utilizes a 10 micron (nominal) cellulose media to remove particulate from gasoline and diesel fuels including Ethanol blended gasoline, Biodiesel and ULSD (Ultra Low Sulfur Diesel). Removes particulate 10 microns (nominal) or larger.
- The PetroClear® model 41130P utilizes a 30 micron (nominal) cellulose media to remove particulate from gasoline and diesel fuels including Ethanol blended gasoline, Biodiesel and ULSD (Ultra Low Sulfur Diesel). Removes particulate 30 microns (nominal) or larger.
- The maximum flow rate for PetroClear® models 41110P and 41130P is 25 gpm (94.6 lpm). Maximum operating pressure is 50 psid (3.4 bar). Collapse pressure is 150 psid (10.3 bar). Maximum operating temperature is 250°F (139°C).
- PetroClear® models 41110P and 41130P utilize a standard 1" – 12 UNF mounting thread ref. (3/4" flow) required for most spin-on filter Adapters used in Gilbarco, Wayne, Bennett, Tokheim and other major manufacturers' dispensers, as well as with Adapters used in the aftermarket.
- Adapters are available for models 41110P and 41130P in aluminum and cast iron. Single Adapters are available in both 3/4" and 1" NPT and BSP inlet/outlet threads.

NOTE: If you experience frequent filter changes, it is recommended that you have fuel samples analyzed to determine the source of contamination, such as water, dirt, rust, bacteria, phase separation, etc.

41110P and 41130P

For Fuel Dispensers

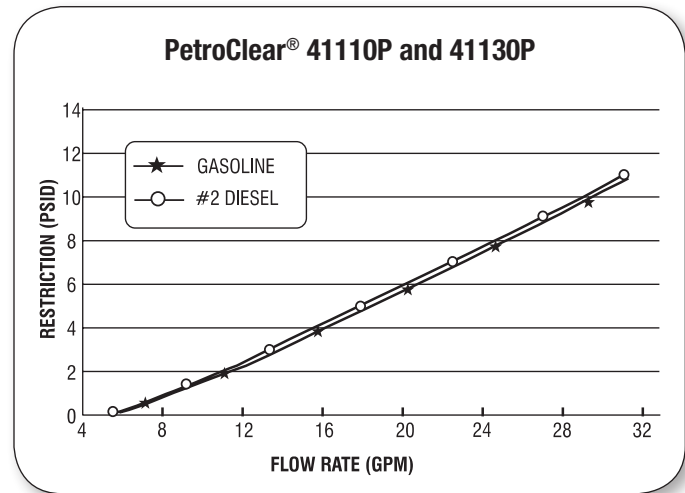
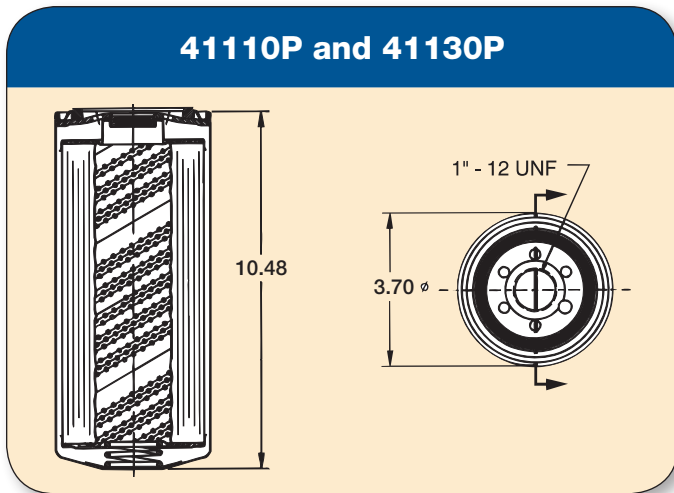

Model	41110P	41130P
Filter Type	Spin-On	Spin-On
Media Type	*Cellulose	*Cellulose
Micron Rating	10 Micron (nominal)	30 Micron (nominal)
Diameter	3.70"	3.70"
Height	10.48"	10.48"
Mounting Thread	1" - 12 UNF	1" - 12 UNF
Flow Rate	25 gpm (94.6 lpm)	25 gpm (94.6 lpm)
Flow	3/4" flow	3/4" flow
Shell Thickness	0.020	0.020
Gasket Material	Buna N	Buna N
Collapse (Min.)	150 psid (10.3 bar)	150 psid (10.3 bar)
Burst (Min.)	250 psi (17.2 bar)	250 psi (17.2 bar)
Max. Operating Temp.	250°F (139°C)	250°F (139°C)

*Particulate Removing

Available Adapters

Part/Model Number	Description
.75 N1-12	3/4" NPT Inlet/Outlet Ports, 1" - 12 UNF (cast iron)
.75 N1-12A	3/4" NPT Inlet/Outlet Ports, 1" - 12 UNF (aluminum)
1.00N-12	1" NPT Inlet/Outlet Ports, 1" - 12 UNF (cast iron)
1.00N1-12A	1" NPT Inlet/Outlet Ports, 1" - 12 UNF (aluminum)
.75 B1-12	3/4" BSP Inlet/Outlet Ports, 1" - 12 UNF (aluminum)
1.00B1-12	1" BSP Inlet/Outlet Ports, 1" - 12 UNF (aluminum)

411 Series-AD “Alert”

Particulate Removal and Phase Separation Detection In Alcohol Blended Fuels



41110A-AD and 41130A-AD

Detects Phase Separation in
Ethanol Blended Gasoline

FOR DISPOSAL INFORMATION PLEASE CONTACT YOUR NEAREST EPA OFFICE.

Benefits

- The “Alert” models 41110A-AD and 41130A-AD are designed to remove particulate and to detect and react to phase separation in Ethanol blended gasoline and slow flow as an indicator to the presence of phase separation. IT WILL NOT SENSE NOR REACT TO WATER IN NON-ALCOHOL BLENDED GASOLINE (NEAT GASOLINE).
- PetroClear® model 41110A-AD filter offers efficient 10 micron (nominal) particulate removal and detects phase separation.
- PetroClear® model 41130A-AD filter offers efficient 30 micron (nominal) particulate removal and detects phase separation.
- Textured paint coating helps ensure a simple, mess-free installation and removal process.
- UL® recognized

PetroClear® Filters are NOT to be used in Aviation Fuel Applications!

Specifications

- The PetroClear® model 41110A-AD utilizes a 10 micron (nominal) cellulose media to remove particulate from Ethanol blended gasoline. Removes particulate 10 microns (nominal) or larger.
- The PetroClear® model 41130A-AD utilizes a 30 micron (nominal) cellulose media to remove particulate from Ethanol blended gasoline. Removes particulate 30 microns (nominal) or larger.
- The “Alert” models 41110A-AD and 41130A-AD are designed to detect and react to phase separation in Ethanol blended gasoline.
- The maximum flow rate for PetroClear® models 41110A-AD and 41130A-AD is 25 gpm (94.6 lpm). Maximum operating pressure is 50 psid (3.4 bar). Collapse pressure is 150 psid (10.3 bar). Maximum operating temperature is 250°F (139°C).
- The chemical center core assembly detects and reacts to phase separation and significantly restricts flow through filters.
- PetroClear® models 41110A-AD and 41130A-AD utilize a standard 1.5"-16 UNF mounting thread ref. (1" flow) required for most spin-on filter adapters used in aftermarket.
- Adapters are available for models 41110A-AD and 41130A-AD in aluminum. These single adapters are available in both 3/4" and 1" NPT or BSP inlet/outlet threads.

NOTE: If you experience frequent filter changes, it is recommended that you have fuel samples analyzed to determine the source of contamination, such as water, dirt, rust, bacteria, phase separation, etc.

41110A-AD and 41130A-AD Series The “Alert” Detects Phase Separation

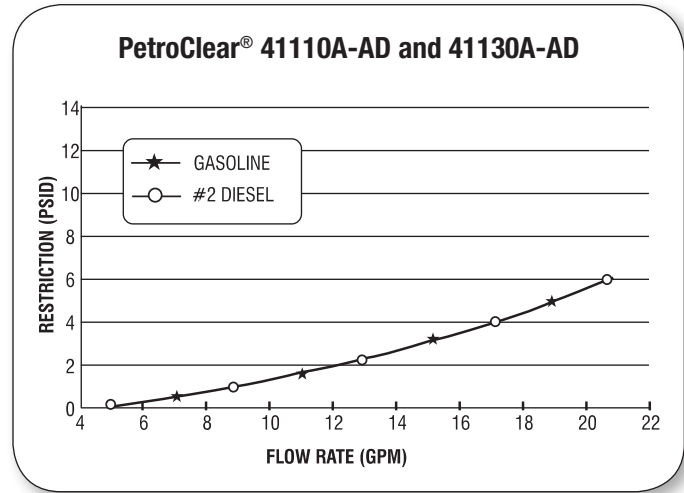
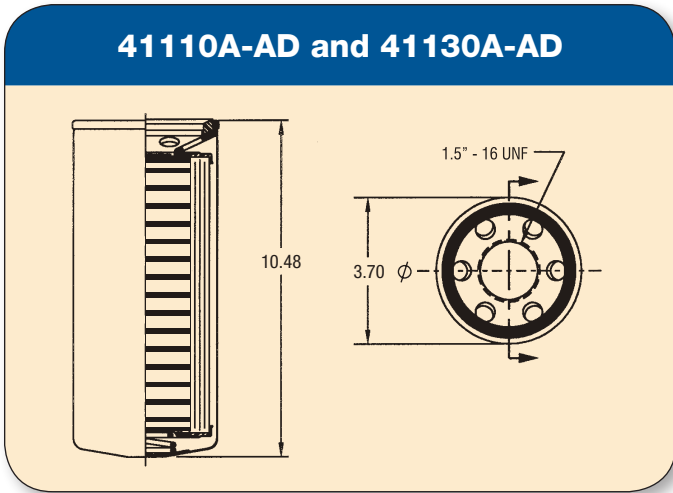

Model	41110A-AD	41130A-AD
Filter Type	Spin-On	Spin-On
Media Type	*Cellulose with Chemical Core	*Cellulose with Chemical Core
Micron Rating	10 Micron (nominal)	30 Micron (nominal)
Diameter	3.70"	3.70"
Height	10.48"	10.48"
Mounting Thread	1.5" – 16 UNF	1.5" – 16 UNF
Flow Rate	25 gpm (94.6 lpm)	25 gpm (94.6 lpm)
Flow	1" flow	1" flow
Shell Thickness	0.020	0.020
Gasket Material	Buna N	Buna N
Collapse (Min.)	150 psid (10.3 bar)	150 psid (10.3 bar)
Burst (Min.)	500 psi (34.5 bar)	500 psi (34.5 bar)
Max. Operating Temp.	250°F (139°C)	250°F (139°C)
Min. Operating Temp.	-20°F (-28.9°C)	-20°F (-28.9°C)

*Particulate Removing and Chemical Core Detects Phase Separation

Available Adapters

Part/Model Number	Description
.75 N1.5-16AD	3/4" NPT Inlet/Outlet Ports, 1.5" – 16 UNF (aluminum)
1.0 N1.5-16AD	1" NPT Inlet/Outlet Ports, 1.5" – 16 UNF (aluminum)
.75B1.5-16ADA	3/4" BSP Inlet/Outlet Ports, 1"-16 UNF (aluminum)
1.00B1.5-16ADA	1" BSP Inlet/Outlet Ports, 1"-16 UNF (aluminum)

411-AD Series

Particulate Removing



41110P-AD and 41130P-AD

Extended Life Particulate
For High-Flow Fuel Dispensers

FOR DISPOSAL INFORMATION PLEASE CONTACT YOUR NEAREST EPA OFFICE.

Benefits

- The 41110P-AD and 41130P-AD are designed to remove particulate from gasoline, Ethanol blended gasolines, diesels, Biodiesel, ULSD (Ultra Low Sulfur Diesel), Kerosene and fuel oils.
- PetroClear® models 41110P-AD and 41130P-AD are particulate spin-on filters. These filters are designed for particulate removal only and WILL NOT REACT TO WATER IN NEAT GASOLINE OR DETECT PHASE SEPARATION IN ETHANOL BLENDED GASOLINE TO SLOW FLOW.
- PetroClear® model 41110P-AD filter offers efficient 10 micron (nominal) particulate removal.
- PetroClear® model 41130P-AD filter offers efficient 30 micron (nominal) particulate removal.
- Textured paint coating helps ensure a simple, mess-free installation and removal process.
- UL® recognized
- Compatible with neat gasoline, Ethanol blended fuels and all diesels including Biodiesels.

PetroClear® Filters are NOT to be used in Aviation Fuel Applications!

Specifications

- The PetroClear® model 41110P-AD utilizes a 10 micron (nominal) cellulose media to remove particulate from gasolines and diesel fuels including Ethanol blended gasoline, Biodiesel and ULSD (Ultra Low Sulfur Diesel). Removes particulate 10 microns (nominal) or larger.
- The PetroClear® model 41130P-AD utilizes a 30 micron (nominal) cellulose media to remove particulate from gasolines and diesel fuels including Ethanol blended gasoline, Biodiesel and ULSD (Ultra Low Sulfur Diesel). Removes particulate 30 microns (nominal) or larger.
- The maximum flow rate for PetroClear® models 41110P-AD and 41130P-AD is 25 gpm (94.6 lpm). Maximum operating pressure is 50 psid (3.4 bar). Collapse pressure is 150 psid (10.3 bar). Maximum operating temperature is 250°F (139°C).
- PetroClear® models 41110P-AD and 41130P-AD utilize a standard 1.5"-16 UNF mounting thread ref. (1" flow) required for most spin-on filter Adapters used in aftermarket and/or high-flow applications, such as in Gilbarco, Wayne, Bennett, Tokheim and other major manufacturers' dispensers.
- Adapters are available for models 41110P-AD and 41130P-AD in aluminum. These single Adapters are available in 3/4" and 1" NPT and BSP inlet/outlet threads.

NOTE: If you experience frequent filter changes, it is recommended that you have fuel samples analyzed to determine the source of contamination, such as water, dirt, rust, bacteria, phase separation, etc.

41110P-AD and 41130P-AD

Extended Life for High-Flow Fuel Dispensers

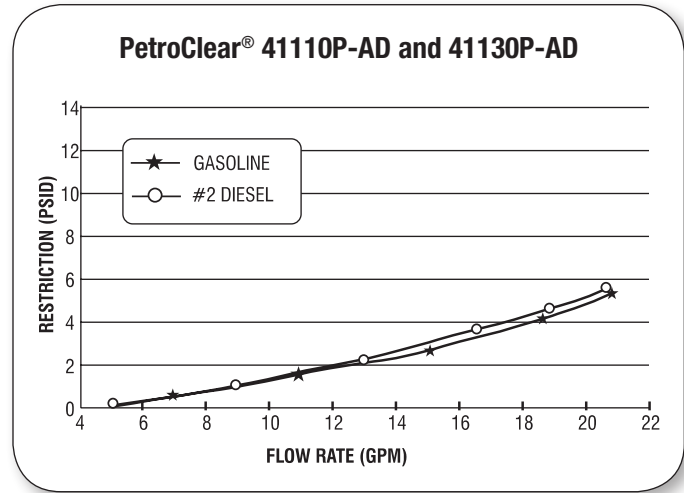
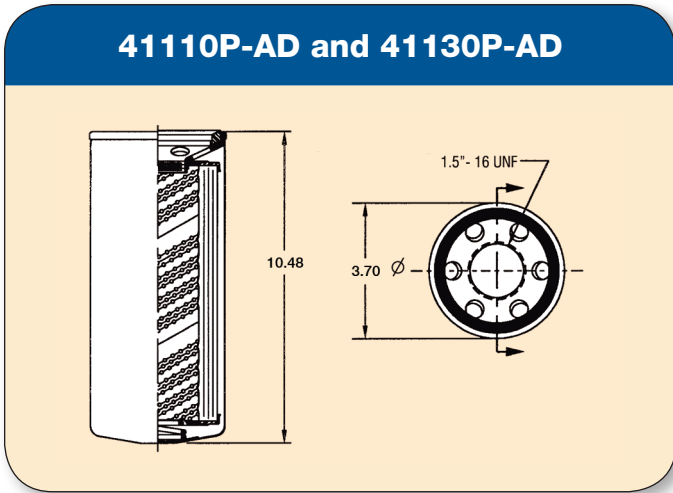

Model	41110P-AD	41130P-AD
Filter Type	Spin-On	Spin-On
Media Type	*Cellulose	*Cellulose
Micron Rating	10 Micron (nominal)	30 Micron (nominal)
Diameter	3.70"	3.70"
Height	10.48"	10.48"
Mounting Thread	1.5" – 16 UNF	1.5" – 16 UNF
Flow Rate	25 gpm (94.6 lpm)	25 gpm (94.6 lpm)
Flow	1" flow	1" flow
Shell Thickness	0.020	0.020
Gasket Material	Buna N	Buna N
Collapse (Min.)	150 psid (10.3 bar)	150 psid (10.3 bar)
Burst (Min.)	500 psi (34.5 bar)	500 psi (34.5 bar)
Max. Operating Temp.	250°F (139°C)	250°F (139°C)

*Particulate Removing

Available Adapters

Part/Model Number	Description
.75 N1.5-16AD	3/4" NPT Inlet/Outlet Ports, 1.5" – 16 UNF (aluminum)
1.0 N1.5-16AD	1" NPT Inlet/Outlet Ports, 1.5" – 16 UNF (aluminum)
.75B1.5-16ADA	3/4" BSP Inlet/Outlet Ports, 1"-16 UNF (aluminum)
1.00B1.5-16ADA	1" BSP Inlet/Outlet Ports, 1"-16 UNF (aluminum)

411 Series

Water Sensing & Particulate Removing



41110W and 41130W

Extended Life Water Sensing
For Dispenser Use

FOR DISPOSAL INFORMATION PLEASE CONTACT YOUR NEAREST EPA OFFICE.

Benefits

- The 41110W and 41130W are designed to remove particulate and to sense both free and emulsified water from neat gasoline, diesel, Biodiesel, ULSD (Ultra Low Sulfur Diesel), Kerosene, and fuel oils. This filter will not sense nor react to water in Ethanol-blended gasoline. (Reaction known as phase separation)
- PetroClear® models 41110W and 41130W are particulate and water sensing spin-on filters. These filters are designed to sense water, both free and emulsified, and slow flow as an indicator of the presence of water in neat gasoline and diesel fuels.
- PetroClear® model 41110W filter offers efficient 10 micron (nominal) particulate removal and senses both free and emulsified water in neat gasoline and diesel fuels.
- PetroClear® model 41130W filter offers efficient 30 micron (nominal) particulate removal and senses both free and emulsified water in neat gasoline and diesel fuels.
- Textured paint coating helps ensure a simple, mess-free installation and removal process.
- UL® recognized
- Will not detect phase separation in Ethanol blended fuels.

PetroClear® Filters are NOT to be used in Aviation Fuel Applications!

Specifications

- The PetroClear® model 41110W utilizes a 10 micron (nominal) cellulose media to remove particulate from gasoline and diesel fuels including Biodiesel and ULSD (Ultra Low Sulfur Diesel). Removes particulate 10 microns (nominal) or larger, with water sensing capability in neat gasoline and diesel fuels.
- The PetroClear® model 41130W utilizes a 30 micron (nominal) cellulose media to remove particulate from gasoline and diesel fuels including Biodiesel and ULSD (Ultra Low Sulfur Diesel). Removes particulate 30 microns (nominal) or larger, with water sensing capability in neat gasoline and diesel fuels.
- Once PetroClear® models 41110W and 41130W have absorbed 12.8 ounces (378 mil) of water from neat gasoline or diesel fuel, flow will be noticeably slow.
- The maximum flow rate for PetroClear® models 41110W and 41130W is 25 gpm (94.6 lpm). Maximum operating pressure is 50 psid (3.4 bar). Collapse pressure is 150 psid (10.3 bar). Maximum operating temperature is 250°F (139°C).
- PetroClear® models 41110W and 41130W utilize a standard 1"-12 UNF mounting thread ref. (3/4" flow) required for most spin-on filter Adapters used in Gilbarco, Wayne, Bennett, Tokheim and other major manufacturers' dispensers, as well as with Adapters used in the aftermarket.
- Adapters are available for models 41110W and 41130W in aluminum and cast iron. These single Adapters are available in both 3/4" and 1" NPT or BSP inlet/outlet threads.

NOTE: If you experience frequent filter changes, it is recommended that you have fuel samples analyzed to determine the source of contamination, such as water, dirt, rust, bacteria, phase separation, etc.

4110W and 41130W

For Fuel Dispensers

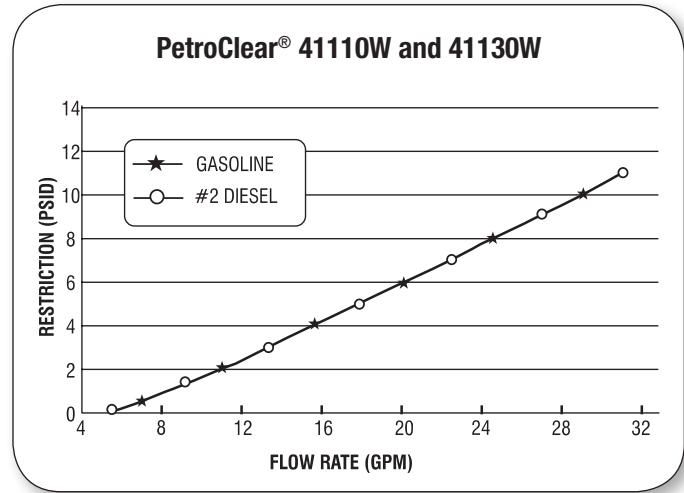
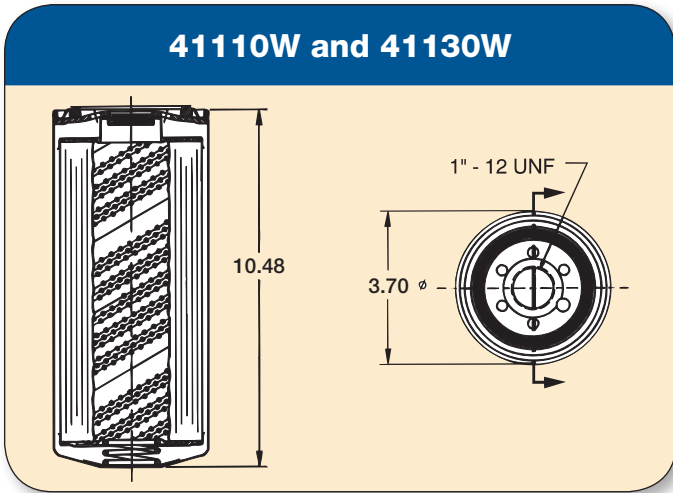

Model	4110W	41130W
Filter Type	Spin-On	Spin-On
Media Type	*Cellulose with Super Absorbent Media	*Cellulose with Super Absorbent Media
Micron Rating	10 Micron (nominal)	30 Micron (nominal)
Diameter	3.70"	3.70"
Height	10.48"	10.48"
Mounting Thread	1" - 12 UNF	1" - 12 UNF
Flow Rate	25 gpm (94.6 lpm)	25 gpm (94.6 lpm)
Flow	3/4" flow	3/4" flow
Shell Thickness	0.020	0.020
Gasket Material	Buna N	Buna N
Collapse (Min.)	150 psid (10.3 bar)	150 psid (10.3 bar)
Burst (Min.)	250 psi (17.2 bar)	250 psi (17.2 bar)
Max. Operating Temp.	250°F (139°C)	250°F (139°C)

*Water Sensing & Particulate Removing

Available Adapters

Part/Model Number	Description
.75 N1-12	3/4" NPT Inlet/Outlet Ports, 1" - 12 UNF (cast iron)
.75 N1-12A	3/4" NPT Inlet/Outlet Ports, 1" - 12 UNF (aluminum)
1.00N-12	1" NPT Inlet/Outlet Ports, 1" - 12 UNF (cast iron)
1.00N1-12A	1" NPT Inlet/Outlet Ports, 1" - 12 UNF (aluminum)
.75 B1-12	3/4" BSP Inlet/Outlet Ports, 1" - 12 UNF (aluminum)
1.00B1-12	1" BSP Inlet/Outlet Ports, 1" - 12 UNF (aluminum)

411-AD Series

Water Sensing & Particulate Removing



41110W-AD and 41130W-AD

Extended Life For High-Flow
Fuel Dispensers

FOR DISPOSAL INFORMATION PLEASE CONTACT YOUR NEAREST EPA OFFICE.

Benefits

- The 41110W-AD and 41130W-AD are designed to remove particulate and to sense both free and emulsified water from neat gasoline, diesel, Biodiesel, ULSD (Ultra Low Sulfur Diesel), Kerosene, fuel oils. This filter will not react to phase separation in alcohol blended gasolines by slowing flow.
- PetroClear® models 41110W-AD and 41130W-AD are particulate and water sensing spin-on filters. These filters are designed to sense water, both free and emulsified, and slow flow as an indicator of the presence of water in neat gasoline and Diesel fuels.
- PetroClear® model 41110W-AD filter offers efficient 10 micron (nominal) particulate removal and senses both free and emulsified water from neat gasoline or diesel fuel.
- PetroClear® model 41130W-AD filter offers efficient 30 micron (nominal) particulate removal and senses both free and emulsified water in neat gasoline and diesel fuels.
- Textured paint coating helps ensure a simple, mess-free installation and removal process.
- UL® recognized
- Will not detect phase separation in Ethanol blended fuels.

PetroClear® Filters are NOT to be used in Aviation Fuel Applications!

Specifications

- The PetroClear® model 41110W-AD utilizes a 10 micron (nominal) cellulose media to remove particulate from gasoline and diesel fuels including Biodiesel and ULSD (Ultra Low Sulfur Diesel). Removes particulate 10 microns (nominal) or larger, with water sensing capability in neat gasoline and diesel fuel.
- The PetroClear® model 41130W-AD utilizes a 30 micron (nominal) cellulose media to remove particulate from gasoline and diesel fuels including Biodiesel and ULSD (Ultra Low Sulfur Diesel). Removes particulate 30 microns (nominal) or larger, with water sensing capability in neat gasoline and diesel fuel.
- Once PetroClear® models 41110W-AD and 41130W-AD have absorbed 12.8 ounces (378 mil) of water from neat gasoline or diesel fuel, flow will be noticeably slow.
- The maximum flow rate for PetroClear® models 41110W-AD and 41130W-AD is 25 gpm (94.6 lpm). Maximum operating pressure is 50 psid (3.4 bar). Collapse pressure is 150 psid (10.3 bar). Maximum operating temperature is 250°F (139°C).
- PetroClear® models 41110W-AD and 41130W-AD utilize a standard 1.5" – 16 UNF mounting thread ref. (1" flow) required for most spin-on filter Adapters used in aftermarket and/or high-flow applications such as in Gilbarco, Wayne, Bennett, Tokheim and other major manufacturers' dispensers.
- Adapters are available for models 41110W-AD and 41130W-AD in aluminum. These single Adapters are available in 3/4" and 1" NPT and BSP inlet/outlet threads.

NOTE: If you experience frequent filter changes, it is recommended that you have fuel samples analyzed to determine the source of contamination, such as water, dirt, rust, bacteria, phase separation, etc.

411-AD Series

Water Sensing & Particulate Removing

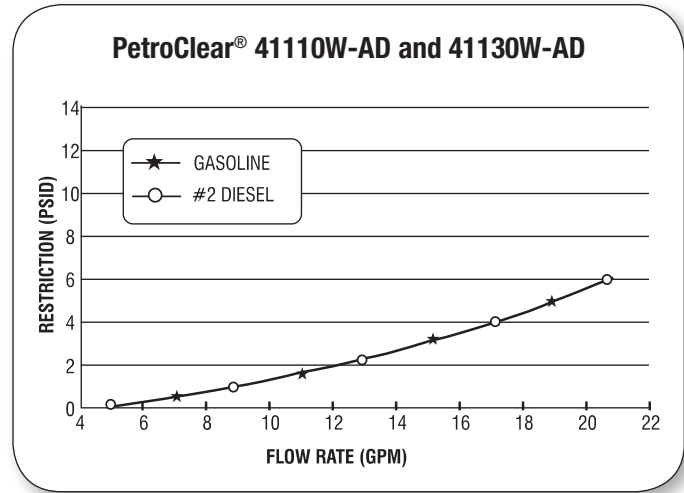
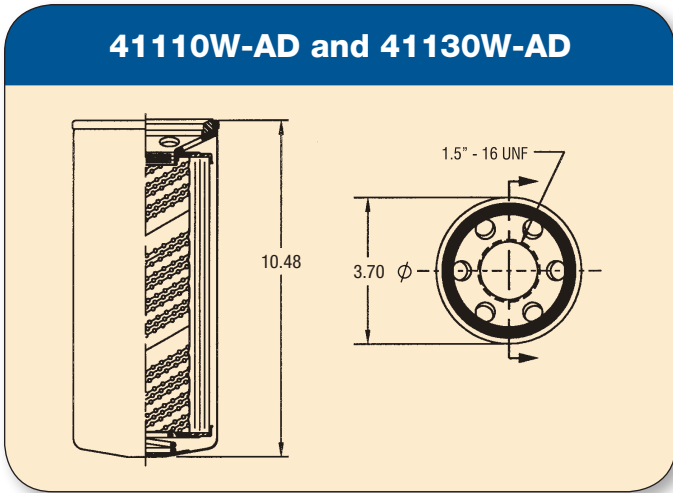

Model	41110W-AD	41130W-AD
Filter Type	Spin-On	Spin-On
Media Type	*Cellulose with Super Absorbent Media	*Cellulose with Super Absorbent Media
Micron Rating	10 Micron (nominal)	30 Micron (nominal)
Diameter	3.70"	3.70"
Height	10.48"	10.48"
Mounting Thread	1.5" – 16 UNF	1.5" – 16 UNF
Flow Rate	25 gpm (94.6 lpm)	25 gpm (94.6 lpm)
Flow	1" flow	1" flow
Shell Thickness	0.020	0.020
Gasket Material	Buna N	Buna N
Collapse (Min.)	150 psid (10.3 bar)	150 psid (10.3 bar)
Burst (Min.)	500 psi (34.5 bar)	500 psi (34.5 bar)
Max. Operating Temp.	250°F (139°C)	250°F (139°C)

*Water Sensing & Particulate Removing

Available Adapters

Part/Model Number	Description
.75 N1.5-16AD	3/4" NPT Inlet/Outlet Ports, 1.5" – 16 UNF (aluminum)
1.0 N1.5-16AD	1" NPT Inlet/Outlet Ports, 1.5" – 16 UNF (aluminum)
.75B1.5-16ADA	3/4" BSP Inlet/Outlet Ports, 1"-16 UNF (aluminum)
1.00B1.5-16ADA	1" BSP Inlet/Outlet Ports, 1"-16 UNF (aluminum)

411 D Series “Dual Purpose”

Removes Particulate,
Detects Phase Separation & Senses Water

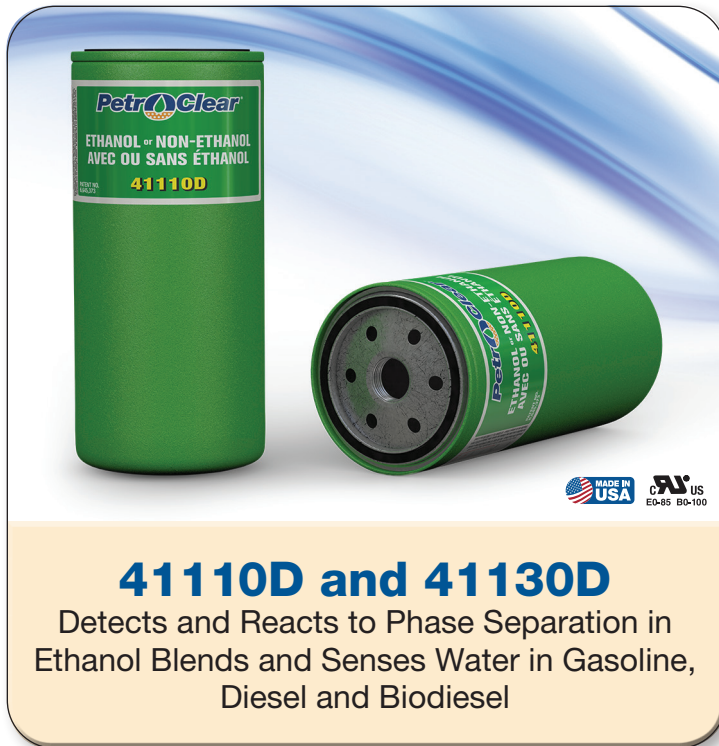
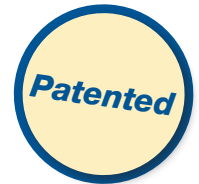

41110D and 41130D

Detects and Reacts to Phase Separation in
Ethanol Blends and Senses Water in Gasoline,
Diesel and Biodiesel

FOR DISPOSAL INFORMATION PLEASE CONTACT YOUR NEAREST EPA OFFICE.

Benefits

- PetroClear® models 41110D and 41130D are spin-on filters designed to remove particulate in gasoline, ethanol blends, diesel and biodiesel. PetroClear® models 41110D and 41130D sense both free and emulsified water in neat gasoline, diesel and biodiesel. PetroClear® models 41110D and 41130D detect and react to phase separation in ethanol blended gasoline and slow flow as an indicator to the presence of phase separation.
- PetroClear® model 41110D offers efficient 10 micron (nominal) particulate removal, senses both free and emulsified water and detects and reacts to phase separation.
- PetroClear® model 41130D offers efficient 30 micron (nominal) particulate removal, senses both free and emulsified water and detects and reacts to phase separation.
- The “dual purpose” models provide protection during the transition from neat gasoline to ethanol blends without the need to change filters.
- Textured paint coating helps ensure a simple, mess-free installation and removal process.
- UL® recognized.

PetroClear® Filters are NOT to be used in Aviation Fuel Applications!

Specifications

- The PetroClear® model 41110D utilizes a 10 micron (nominal) cellulose media to remove particulate 10 microns (nominal) or larger from neat gasoline, ethanol blends, diesel and biodiesel. The PetroClear® model 41110D also senses water in neat gasoline, diesel and biodiesel. The PetroClear® model 41110D provides phase separation detecting capabilities for ethanol-blended gasoline. It utilizes a super absorbent media for sensing water and a chemical core assembly to detect and react to phase separation.
- The PetroClear® model 41130D utilizes a 30 micron (nominal) cellulose media to remove particulate 30 microns (nominal) or larger from neat gasoline, ethanol blends, diesel and biodiesel. The PetroClear® model 41130D also senses water in neat gasoline, diesel and biodiesel. The PetroClear® model 41130D provides phase separation detecting capabilities for ethanol-blended gasoline. It utilizes a super absorbent media for sensing water and a chemical core assembly to detect and react to phase separation.
- Once PetroClear® models 41110D and 41130D have absorbed 12.8 ounces (378 mil) of water, flow will be noticeably slow.
- The center chemical core assembly detects and reacts to phase separation and significantly restricts flow through filters.
- The maximum flow rate for PetroClear® models 41110D and 41130D is 25 gpm (94.6 lpm). Maximum operating pressure is 50 psid (3.4 bar).
- Collapse pressure is 150 psid (10.3 bar). Maximum operating temperature is 250°F (139°C).
- PetroClear® 41110D and 41130D “Dual Purpose” filters utilize a standard 1" – 12 UNF mounting thread ref. (3/4" flow) required for most spin-on filter Adapters used in Gilbarco, Wayne, Bennett, Tokheim and other major manufacturers’ dispensers, as well as with Adapters used in the aftermarket.
- Adapters are available for models 41110D and 41130D in aluminum and cast iron. These single Adapters are available in both 3/4" and 1" NPT and BSP inlet/outlet threads.

NOTE: If you experience frequent filter changes, it is recommended that you have fuel samples analyzed to determine the source of contamination, such as water, dirt, rust, bacteria, phase separation, etc.

41110D and 41130D “Dual Purpose”

Removes Particulate, Detects Phase Separation & Senses Water

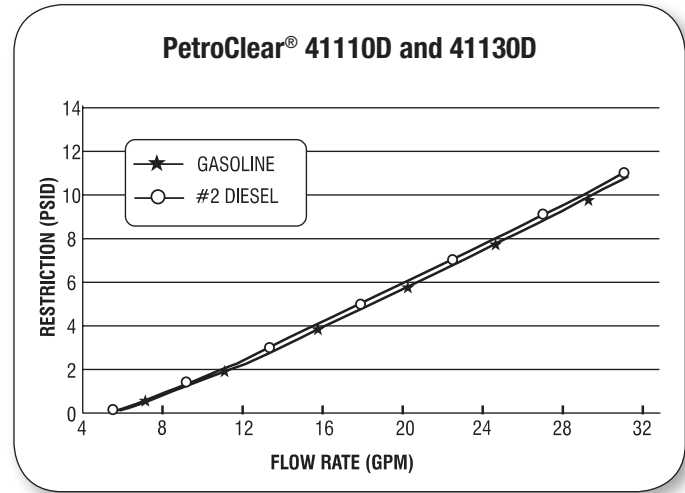
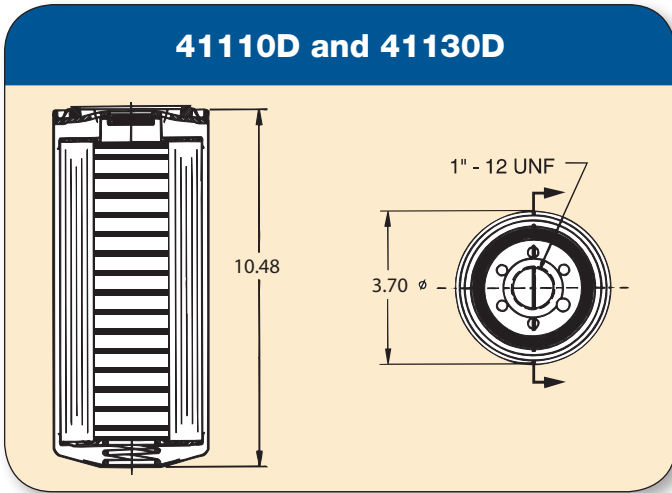

Model	41110D	41130D
Filter Type	Spin-On	Spin-On
Media Type	Cellulose* with Super Absorbent Media** and Chemical Core***	Cellulose* with Super Absorbent Media** and Chemical Core***
Micron Rating	10 Micron (nominal)	30 Micron (nominal)
Diameter	3.70"	3.70"
Height	10.48"	10.48"
Mounting Thread	1" – 12 UNF	1" – 12 UNF
Flow Rate	25 gpm (94.6 lpm)	25 gpm (94.6 lpm)
Flow	3/4" flow	3/4" flow
Shell Thickness	0.020	0.020
Gasket Material	Buna N	Buna N
Collapse (Min.)	150 psid (10.3 bar)	150 psid (10.3 bar)
Burst (Min.)	250 psi (17.2 bar)	250 psi (17.2 bar)
Max. Operating Temp.	250°F (139°C)	250°F (139°C)
Min. Operating Temp.	-20°F (-28.9°C)	-20°F (-28.9°C)

*Particulate Removing, **Water Sensing, ***Detects Phase Separation

Available Adapters

Part/Model Number	Description
.75 N1-12	3/4" NPT Inlet/Outlet Ports, 1" – 12 UNF (cast iron)
.75 N1-12A	3/4" NPT Inlet/Outlet Ports, 1" – 12 UNF (aluminum)
1.00N-12	1" NPT Inlet/Outlet Ports, 1" – 12 UNF (cast iron)
1.00N1-12A	1" NPT Inlet/Outlet Ports, 1" – 12 UNF (aluminum)
.75 B1-12	3/4" BSP Inlet/Outlet Ports, 1" – 12 UNF (aluminum)
1.00B1-12	1" BSP Inlet/Outlet Ports, 1" – 12 UNF (aluminum)

411 D-AD Series “Dual Purpose”

Removes Particulate,
Detects Phase Separation & Senses Water

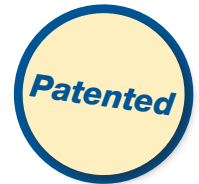

41110D-AD and 41130D-AD

Detects and Reacts to Phase Separation in Ethanol Blends and Senses Water in Gasoline, Diesel and Biodiesel

FOR DISPOSAL INFORMATION PLEASE CONTACT YOUR NEAREST EPA OFFICE.

Benefits

- PetroClear® models 41110D-AD and 41130D-AD are spin-on filters designed to remove particulate in gasoline, ethanol blends, diesel and biodiesel. PetroClear® models 41110D-AD and 41130D-AD sense both free and emulsified water in neat gasoline, diesel and biodiesel. PetroClear® models 41110D-AD and 41130D-AD detect and react to phase separation in Ethanol blended gasoline and slow flow as an indicator to the presence of phase separation.
- PetroClear® model 41110D-AD offers efficient 10 micron (nominal) particulate removal, senses both free and emulsified water and detects and reacts to phase separation.
- PetroClear® model 41130D-AD offers efficient 30 micron (nominal) particulate removal, senses both free and emulsified water and detects and reacts to phase separation.
- The “dual purpose” models provide protection during the transition from neat gasoline to ethanol blends without the need to change filters.
- Textured paint coating helps ensure a simple, mess-free installation and removal process.
- UL® recognized.

PetroClear® Filters are NOT to be used in Aviation Fuel Applications!

Specifications

- The PetroClear® model 41110D-AD utilizes a 10 micron (nominal) cellulose media to remove particulate 10 microns (nominal) or larger from neat gasoline, ethanol blends, diesel and biodiesel. The PetroClear® model 41110D-AD also senses water in neat gasoline, diesel and biodiesel. The PetroClear® model 41110D-AD provides phase separation detecting capabilities for ethanol-blended gasoline. It utilizes a super absorbent media for sensing water and a chemical core assembly to detect and react to phase separation.
- The PetroClear® model 41130D-AD utilizes a 30 micron (nominal) cellulose media to remove particulate 30 microns (nominal) or larger from neat gasoline, ethanol blends, diesel and biodiesel. The PetroClear® model 41130D-AD also senses water in neat gasoline, diesel and biodiesel. The PetroClear® model 41130D-AD provides phase separation detecting capabilities for ethanol-blended gasoline. It utilizes a super absorbent media for sensing water and a chemical core assembly to detect and react to phase separation.
- Once PetroClear® models 41110D-AD and 41130D-AD have absorbed 12.8 ounces (378 mil) of water, flow will be noticeably slow.
- The center chemical core assembly detects and reacts to phase separation and significantly restricts flow through filters.
- The maximum flow rate for PetroClear® models 41110D-AD and 41130D-AD is 25 gpm (94.6 lpm). Maximum operating pressure is 50 psid (3.4 bar).
- Collapse pressure is 150 psid (10.3 bar). Maximum operating temperature is 250°F (139°C).
- PetroClear® models 41110D-AD and 41130D-AD “Dual Purpose” high-flow filters utilize a standard 1.5” – 16 UNF mounting thread ref. (1” flow) required for most spin-on filter adapters used in aftermarket and/or today’s high-flow fuel applications such as in Gilbarco, Wayne, Bennett, Tokheim and other major manufacturers’ dispensers.
- Adapters are available for models 41110D-AD and 41130D-AD in aluminum. These single Adapters are available in both 3/4” and 1” NPT and BSP inlet/outlet threads.

NOTE: If you experience frequent filter changes, it is recommended that you have fuel samples analyzed to determine the source of contamination, such as water, dirt, rust, bacteria, phase separation, etc.

41110D-AD and 41130D-AD “Dual Purpose”

Removes Particulate, Detects Phase Separation & Senses Water

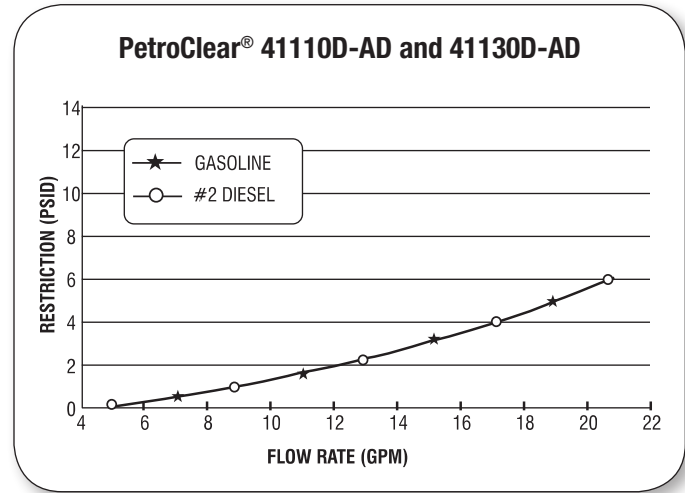
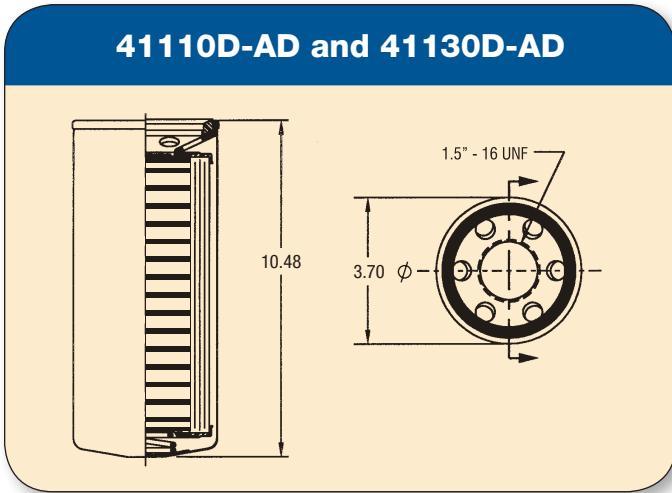

Model	41110D-AD	41130D-AD
Filter Type	Spin-On	Spin-On
Media Type	Cellulose* with Super Absorbent Media** and Chemical Core***	Cellulose* with Super Absorbent Media** and Chemical Core***
Micron Rating	10 Micron (nominal)	30 Micron (nominal)
Diameter	3.70"	3.70"
Height	10.48"	10.48"
Mounting Thread	1.5" – 16 UNF	1.5" – 16 UNF
Flow Rate	25 gpm (94.6 lpm)	25 gpm (94.6 lpm)
Flow	1" flow	1" flow
Shell Thickness	0.020	0.020
Gasket Material	Buna N	Buna N
Collapse (Min.)	150 psid (10.3 bar)	150 psid (10.3 bar)
Burst (Min.)	500 psi (34.5 bar)	500 psi (34.5 bar)
Max. Operating Temp.	250°F (139°C)	250°F (139°C)
Min. Operating Temp.	-20°F (-28.9°C)	-20°F (-28.9°C)

*Particulate Removing, **Water Sensing, ***Detects Phase Separation

Available Adapters

Part/Model Number	Description
.75 N1.5-16AD	3/4" NPT Inlet/Outlet Ports, 1.5" – 16 UNF (aluminum)
1.0 N1.5-16AD	1" NPT Inlet/Outlet Ports, 1.5" – 16 UNF (aluminum)
.75B1.5-16ADA	3/4" BSP Inlet/Outlet Ports, 1"-16 UNF (aluminum)
1.00B1.5-16ADA	1" BSP Inlet/Outlet Ports, 1"-16 UNF (aluminum)

507 Series

Particulate Removing



50710P

For Fuel and Hydraulic Applications

FOR DISPOSAL INFORMATION PLEASE CONTACT YOUR NEAREST EPA OFFICE.

Benefits

- PetroClear® model 50710P is a particulate removing spin-on filter designed for use on fuel and hydraulic suction and return line applications.
- PetroClear® model 50710P is a particulate spin-on filter. It's designed for particulate removal only and WILL NOT REACT TO WATER IN FUELS OR DETECT PHASE SEPARATION IN ETHANOL BLENDED GASOLINE.
- PetroClear® model 50710P filter offers efficient 10 micron (nominal) particulate removal.
- Compatible with Neat Gasoline, Ethanol blended fuels and all Diesel fuels including Biodiesel fuels.

PetroClear® Filters are NOT to be used in Aviation Fuel Applications!

Specifications

- The PetroClear® model 50710P utilizes a 10 micron (nominal) cellulose media to remove particulate from gasoline and diesel fuels including Ethanol blended gasoline, Biodiesel, ULSD (Ultra Low Sulfur Diesel) and most hydraulic fluids. Removes particulate 10 microns (nominal) or larger.
- The maximum flow rate for PetroClear® model 50710P is 40 gpm (151 lpm). Maximum operating pressure is 50 psid (3.4 bar). Collapse pressure is 150 psid (10.3 bar). Maximum operating temperature is 250°F (139°C).
- PetroClear® model 50710P utilizes a standard 1.5"-16 UNF mounting thread ref. (1" flow) required for most spin-on filter adapters used in aftermarket and/or high-flow applications.
- Adapters are available for model 50710P in aluminum. This adapter is available in both NPT or BSP inlet/outlet threads. Inlet/outlet sizes are available in 1" and 1.5" NPT or BSP single adapters. This adapter is also available in a dual style with both 1.5" and 2" inlet/outlet (2"- 4" bolt SAE flange combination).
- Each filter is packaged with a separate gasket that will fit most standard brands of adapter filter mounting bases. Install gasket in adapter's groove by placing in groove at 3 to 4 places and then smoothing gasket between those points. Lubricate with light oil. NOTE: Gasket does not mount on filter!
- If using this filter in a hydraulic/lube oil application, verify that you are applying the filter on a spin-on filter head that has a by-pass valve.

NOTE: If you experience frequent filter changes, it is recommended that you have fuel samples analyzed to determine the source of contamination, such as water, dirt, rust, bacteria, phase separation, etc.

507 Series

Particulate Removing

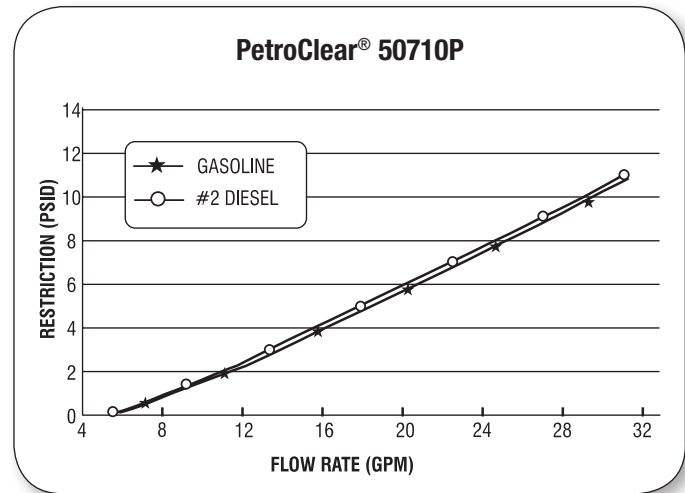
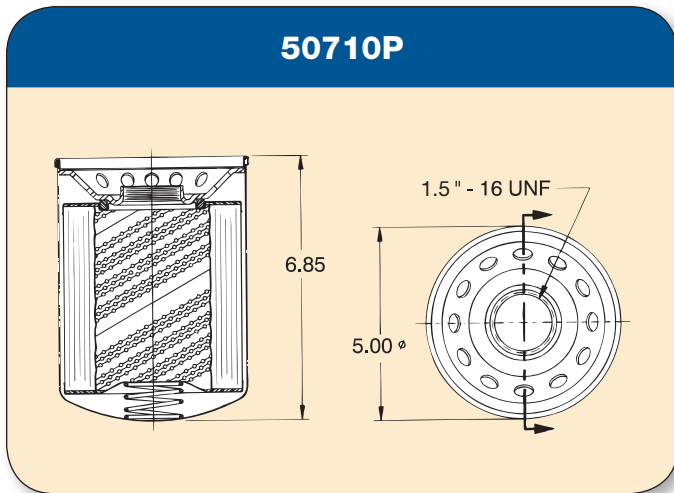

Model	40910W-AD
Filter Type	Spin-On
Media Type	*Cellulose
Micron Rating	10 Micron (nominal)
Diameter	5.00"
Height	6.85"
Mounting Thread	1.5" – 16 UNF
Flow Rate	40 gpm (151 lpm)
Flow	1" flow
Shell Thickness	0.020
Gasket Material	Buna N
Collapse (Min.)	150 psid (10.3 bar)
Burst (Min.)	200 psi (13.5 bar)
Max. Operating Temp.	250°F (139°C)

*Particulate Removing

Available Adapters

Part/Model Number	Description
1.00N1.5-16	1" NPT Inlet/Outlet Ports, 1.5" – 16 UNF (aluminum)
1.00B1.5-16	1" BSP Inlet/Outlet Ports, 1.5" – 16 UNF (aluminum)
1.25N1.5-16A	1-1/4" NPT Inlet/Outlet Ports, 1.5" – 16 UNF (aluminum)
1.50N1.5-16	1-1/2" NPT Inlet/Outlet Ports, 1.5" – 16 UNF (aluminum)
1.5B1.5-16ADA	1.5" BSP Inlet/Outlet Ports, 1.5" – 16 UNF (aluminum)
D1.5B1.5-16	1.5" BSP Inlet/Outlet Ports, 1.5" – 16 UNF (aluminum)
D2.0 N1.5-16*	2" NPT Inlet/Outlet Ports, 1.5" – 16 UNF (aluminum)

*The 4-bolt SAE flange combination allows both 1-1/2" & 2" inlet/outlet combinations.

507 Series

Water Sensing & Particulate Removing



50710W

For Fuel and Hydraulic Applications

Note: Will NOT Sense Water in Ethanol Blended Fuel

FOR DISPOSAL INFORMATION PLEASE CONTACT YOUR NEAREST EPA OFFICE.

Benefits

- PetroClear® model 50710W is a particulate removing and water sensing spin-on filter designed for use on fuel and hydraulic suction and return line applications.
- PetroClear® model 50710W is a particulate and water sensing spin-on filter. These filters are designed to sense water, both free and emulsified, and slow flow as an indicator of the presence of water in neat gasoline, diesel fuels and hydraulic fluids.
- PetroClear® model 50710W filter offers efficient 10 micron (nominal) particulate removal and senses both free and emulsified water in neat gasoline, diesel and hydraulic fluids.
- Will not detect phase separation in Ethanol blended fuels.
- Compatible with Gasoline, Ethanol blended fuels and Diesel fuels, including Biodiesel.
- Textured paint coating helps ensure a simple, mess-free installation and removal process.

PetroClear® Filters are NOT to be used in Aviation Fuel Applications!

Specifications

- The PetroClear® model 50710W utilizes a 10 micron (nominal) cellulose media to remove particulate from gasoline and diesel fuels, Biodiesel and ULSD (Ultra Low Sulfur Diesel). Removes particulate 10 microns (nominal) or larger, with water sensing capability in neat gasoline and diesel fuels.
- The maximum flow rate for PetroClear® model 50710W is 40 gpm (151 lpm). Maximum operating pressure is 50 psid (3.4 bar). Collapse pressure is 150 psid (10.3 bar). Maximum operating temperature is 250°F (139°C).
- PetroClear® model 50710W utilizes a standard 1.5"-16 UNF mounting thread ref. (1" flow) required for most spin-on filter adapters used in aftermarket and/or high-flow applications.
- An adapter is available for model 50710W in aluminum. These adapters are available in both NPT or BSP inlet/outlet threads. Inlet/outlet sizes are available in 3/4" and 1" single adapters. This adapter is also available in a dual style with both 1.5" and 2" inlet/outlet (2"-4" bolt SAE flange combination).
- Each filter is packaged with a separate gasket that will fit most standard brands of adapter filter mounting bases. Install gasket in adapter's groove by placing in groove at 3 to 4 places and then smoothing gasket between those points. Lubricate with light oil. NOTE: Gasket does not mount on filter!
- If using this filter in a hydraulic/lube oil application, verify that you are applying the filter on a spin-on filter head that has a by-pass valve.

NOTE: If you experience frequent filter changes, it is recommended that you have fuel samples analyzed to determine the source of contamination, such as water, dirt, rust, bacteria, phase separation, etc.

507 Series

Water Sensing & Particulate Removing

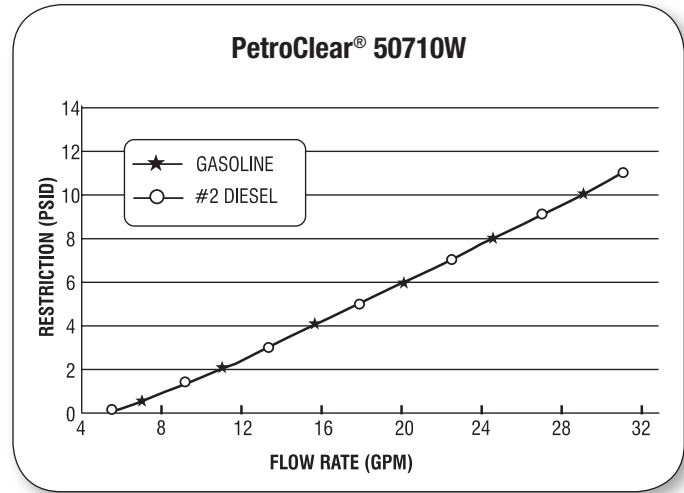
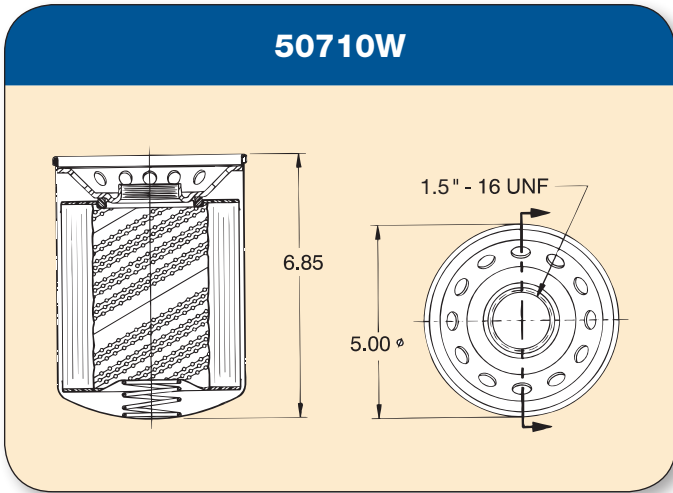

Model	50710W
Filter Type	Spin-On
Media Type	Cellulose with super absorbent media
Micron Rating	10 Micron (nominal)
Diameter	5.00"
Height	6.85"
Mounting Thread	1.5" – 16 UNF
Flow Rate	40 gpm (151 lpm)
Flow	1" flow
Shell Thickness	0.020
Gasket Material	Buna N
Collapse (Min.)	150 psid (10.3 bar)
Burst (Min.)	200 psi (13.5 bar)
Max. Operating Temp.	250°F (139°C)

Available Adapters

Part/Model Number	Description
.75 N1.5-16AD	3/4" NPT Inlet/Outlet Ports, 1.5" – 16 UNF (aluminum)
1.0 N1.5-16AD	1" NPT Inlet/Outlet Ports, 1.5" – 16 UNF (aluminum)
.75B1.5-16ADA	3/4" BSP Inlet/Outlet Ports, 1"-16 UNF (aluminum)
1.00B1.5-16ADA	1" BSP Inlet/Outlet Ports, 1"-16 UNF (aluminum)

511 Series “Alert”

Particulate Removal and Phase Separation Detection in Alcohol Blended Fuels



51110A and 51130A

For High-Flow Fuel Dispensers

Detects Phase Separation in Ethanol Blended Gasoline

FOR DISPOSAL INFORMATION PLEASE CONTACT YOUR NEAREST EPA OFFICE.

Benefits

- PetroClear® model 51110A is a particulate removing and Phase Separation Detecting spin-on filter designed for aftermarket cost efficient filtration of fuels at high volume fueling locations such as truck stops, card lock sites, and industrial and commercial applications.
- The PetroClear® model 51110A “Alert” is a spin on filter designed to remove particulate and to detect and react to phase separation in Ethanol blended gasoline phase separation. IT WILL NOT SENSE NOR REACT TO WATER IN NON-ALCOHOL BLENDED GASOLINE (NEAT GASOLINE).
- PetroClear® model 51110A filter offers efficient 10 micron (nominal) particulate removal and detects phase separation in ethanol blended gasolines.
- PetroClear® model 51110A is a spin-on filter designed to remove particulate, detect and stop flow of phase separation (Ethanol water) in Ethanol blended fuels.
- Textured paint coating helps ensure a simple, mess-free installation and removal process.

PetroClear® Filters are NOT to be used in Aviation Fuel Applications!

Specifications

- The maximum flow rate for PetroClear® model 51110A is 40 gpm (151 lpm). Maximum operating pressure is 50 psi (3.4 bar). Collapse pressure is 150 psid (10.3 bar). Maximum operating temperature is 250°F (139°C).
- PetroClear® model 51110A utilizes a standard 1.5”-16 UNF mounting thread ref. (1” flow) required for most spin-on filter adapters used in aftermarket and/or high-flow applications.
- Adapters are available for model 51110A in aluminum. These adapters are available in both NPT or BSP inlet/outlet threads. Inlet/outlet sizes are available in 1” and 1.5” single adapters. Adapters are also available in a dual style with both 1.5” and 2” inlet/outlet (2”- 4 bolt SAE flange combination).
- Each filter is packaged with a separate gasket that will fit most standard brands of adapter filter mounting bases. Install gasket in adapter’s groove by placing in groove at 3 to 4 places and then smoothing gasket between those points. Lubricate with light oil. NOTE: Gasket does not mount on filter!
- The chemical center core assembly detects and reacts to phase separation and significantly restricts flow through filters.
- The PetroClear® model 51110A utilizes a 10 micron (nominal) cellulose media to remove particulate from Ethanol blended gasoline. Removes particulate 10 microns (nominal) or larger.
- The “Alert” models 51110A is designed to detect and react to phase separation in Ethanol blended gasoline.

NOTE: If you experience frequent filter changes, it is recommended that you have fuel samples analyzed to determine the source of contamination, such as water, dirt, rust, bacteria, phase separation, etc.

511 Series "Alert"

Detects Phase Separation

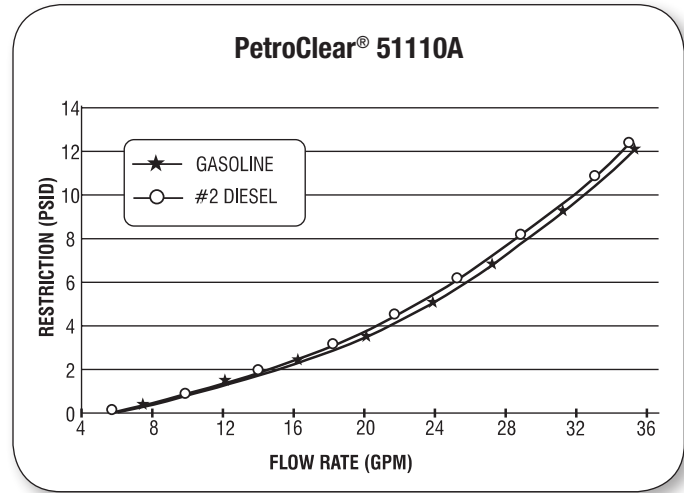
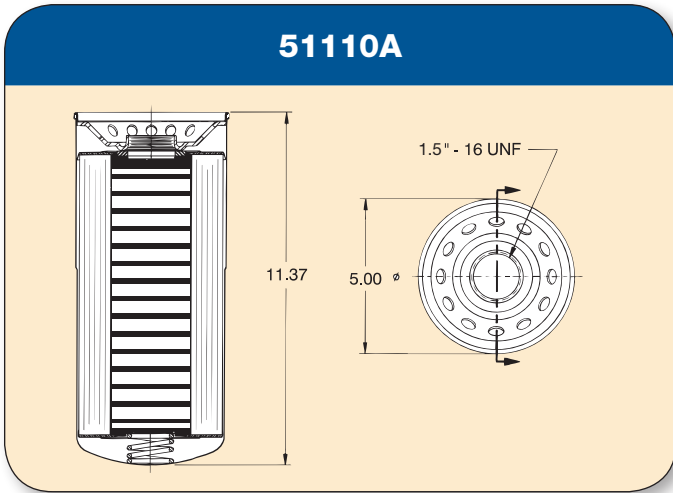

Model	51110A	51130A
Filter Type	Spin-On	Spin-On
Media Type	*Cellulose with Chemical Core	*Cellulose with Chemical Core
Micron Rating	10 Micron (nominal)	30 Micron (nominal)
Diameter	5.00"	5.00"
Height	11.37"	11.37"
Mounting Thread	1.5" – 16 UNF	1.5" – 16 UNF
Flow Rate	40 gpm (151 lpm)	40 gpm (151 lpm)
Flow	1" flow	1" flow
Shell Thickness	0.020	0.020
Gasket Material	Buna N	Buna N
Collapse (Min.)	150 psid (10.3 bar)	150 psid (10.3 bar)
Burst (Min.)	250 psi (17.2 bar)	250 psi (17.2 bar)
Max. Operating Temp.	250°F (139°C)	250°F (139°C)

*Particulate removing and chemical core detects phase separation.

Available Adapters

Part/Model Number	Description
1.00N1.5-16	1" NPT Inlet/Outlet Ports, 1.5" – 16 UNF (aluminum)
1.00B1.5-16	1" BSP Inlet/Outlet Ports, 1.5" – 16 UNF (aluminum)
1.25N1.5-16A	1-1/4" NPT Inlet/Outlet Ports, 1.5" – 16 UNF (aluminum)
1.50N1.5-16	1-1/2" NPT Inlet/Outlet Ports, 1.5" – 16 UNF (aluminum)
1.5B1.5-16ADA	1.5" BSP Inlet/Outlet Ports, 1.5" – 16 UNF (aluminum)
D1.5B1.5-16	1.5" BSP Inlet/Outlet Ports, 1.5" – 16 UNF (aluminum)
D2.0 N1.5-16*	2" NPT Inlet/Outlet Ports, 1.5" – 16 UNF (aluminum)

*The 4-bolt SAE flange combination allows both 1-1/2" & 2" inlet/outlet combinations.

511 Series

Particulate Removing



51103P, 51110P and 51130P

Extended Life For High-Flow Fuel Dispensers

FOR DISPOSAL INFORMATION PLEASE CONTACT YOUR NEAREST EPA OFFICE.

Specifications

- PetroClear® model 51103P utilizes a 3 micron (nominal) cellulose media to remove particulate from gasoline and diesel fuels including Ethanol blended gasoline, Biodiesel, ULSD (Ultra Low Sulfur Diesel), Kerosene, fuel oils and synthetic fluids. Removes particulate 3 microns (nominal) or larger.
- PetroClear® model 51110P utilizes a 10 micron (nominal) cellulose media to remove particulate from gasoline and diesel fuels including Ethanol blended gasoline, Biodiesel, ULSD (Ultra Low Sulfur Diesel), Kerosene, fuel oils and synthetic fluids. Removes particulate 10 microns (nominal) or larger.
- PetroClear® model 51130P utilizes a 30 micron (nominal) cellulose media to remove particulate from gasoline and diesel fuels including Ethanol blended gasoline, Biodiesel, ULSD (Ultra Low Sulfur Diesel), Kerosene, fuel oils and synthetic fluids. Removes particulate 30 microns (nominal) or larger.
- The maximum flow rate for PetroClear® models 51103P, 51110P and 51130P is 40 gpm (151 lpm). Maximum operating pressure is 50 psid (3.4 bar). Collapse pressure is 150 psid (10.3 bar). Maximum operating temperature is 250°F (139°C).
- PetroClear® models 51103P, 51110P and 51130P utilize a standard 1.5"-16 UNF mounting thread ref. (1" flow) required for most spin-on filter adapters used in aftermarket and/or high-flow applications.
- Adapters are available for models 51103P, 51110P and 51130P in aluminum. These adapters are available in both NPT or BSP inlet/outlet threads. Inlet/outlet sizes are available in 1" and 1.5" single adapters. Adapters are also available in a dual style with both 1.5" and 2" inlet/outlet (2"-4" bolt SAE flange combination).
- Each filter is packaged with a separate gasket that will fit most standard brands of adapter filter mounting bases. Install gasket in adapter's groove by placing in groove at 3 to 4 places and then smoothing gasket between those points. Lubricate with light oil. NOTE: Gasket does not mount on filter!
- If using this filter in a hydraulic/lube oil application, verify that you are applying the filter on a spin-on filter head that has a by-pass valve.

Benefits

- PetroClear® 511P filters are particulate removing spin-on filters designed for aftermarket cost efficient particulate filtration of fuels at high volume fueling locations such as truck stops, card lock sites, and industrial and commercial applications.
- PetroClear® models 51103P, 51110P and 51130P spin-on filters are designed to remove particulate from neat gasoline, Ethanol blended gasoline, diesel, Biodiesel, ULSD (Ultra Low Sulfur Diesel), Kerosene, fuel oils, lube oils and synthetic fluids.
- The PetroClear® 511P filter series is designed for particulate removal only and WILL NOT REACT TO WATER IN NEAT GASOLINE OR DETECT PHASE SEPARATION IN ETHANOL BLENDED GASOLINE.
- PetroClear® model 51103P filter offers efficient 03 micron (nominal) particulate removal.
- PetroClear® model 51110P filter offers efficient 10 micron (nominal) particulate removal.
- PetroClear® model 51130P filter offers efficient 30 micron (nominal) particulate removal.

PetroClear® Filters are NOT to be used in Aviation Fuel Applications!

NOTE: If you experience frequent filter changes, it is recommended that you have fuel samples analyzed to determine the source of contamination, such as water, dirt, rust, bacteria, phase separation, etc.

511 Series

Particulate Removing

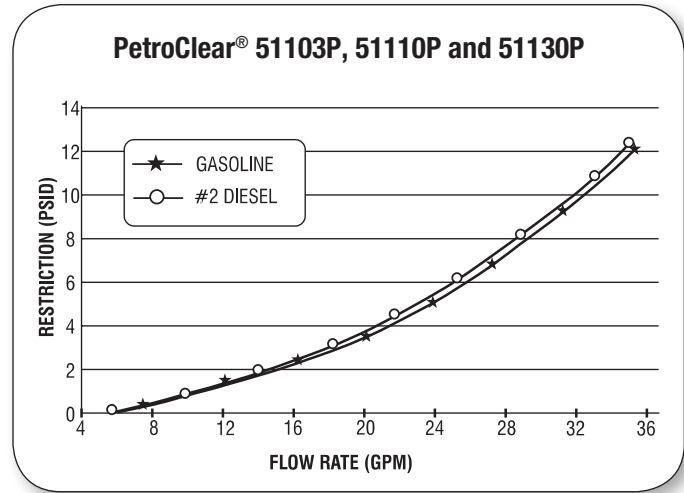
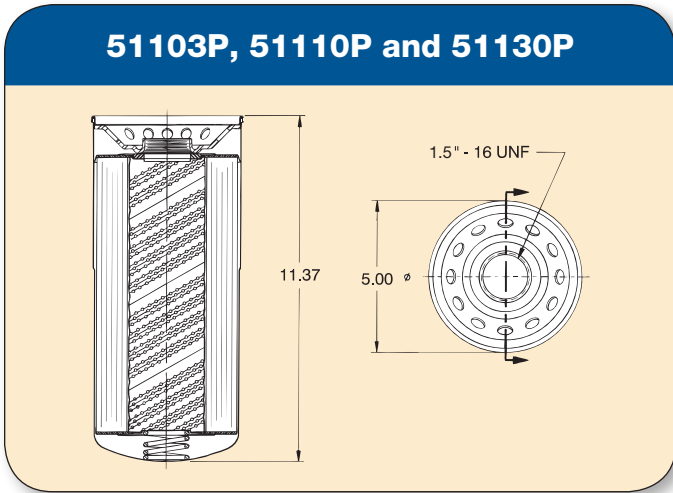

Model	51103P	51110P	51130P
Filter Type	Spin-On	Spin-On	Spin-On
Media Type	*Cellulose	*Cellulose	*Cellulose
Micron Rating	03 Micron (nominal)	10 Micron (nominal)	30 Micron (nominal)
Diameter	5.00"	5.00"	5.00"
Height	11.37"	11.37"	11.37"
Mounting Thread	1.5" -16 UNF	1.5" -16 UNF	1.5" -16 UNF
Flow Rate	40 gpm (151 lpm)	40 gpm (151 lpm)	40 gpm (151 lpm)
Flow	1" flow	1" flow	1" flow
Shell Thickness	0.020	0.020	0.020
Gasket Material	Buna N	Buna N	Buna N
Collapse (Min.)	150 psid (10.3 bar)	150 psid (10.3 bar)	150 psid (10.3 bar)
Burst (Min.)	250 psi (17.2 bar)	250 psi (17.2 bar)	250 psi (17.2 bar)
Max. Operating Temp.	250°F (139°C)	250°F (139°C)	250°F (139°C)

*Particulate Removing

Available Adapters

Part/Model Number	Description
1.00N1.5-16	1" NPT Inlet/Outlet Ports, 1.5" - 16 UNF (aluminum)
1.00B1.5-16	1" BSP Inlet/Outlet Ports, 1.5" - 16 UNF (aluminum)
1.25N1.5-16A	1-1/4" NPT Inlet/Outlet Ports, 1.5" - 16 UNF (aluminum)
1.50N1.5-16	1-1/2" NPT Inlet/Outlet Ports, 1.5" - 16 UNF (aluminum)
1.5B1.5-16ADA	1.5" BSP Inlet/Outlet Ports, 1.5" - 16 UNF (aluminum)
D1.5B1.5-16	1.5" BSP Inlet/Outlet Ports, 1.5" - 16 UNF (aluminum)
D2.0 N1.5-16*	2" NPT Inlet/Outlet Ports, 1.5" - 16 UNF (aluminum)

*The 4-bolt SAE flange combination allows both 1-1/2" & 2" inlet/outlet combinations.

511 Series

Water Sensing & Particulate Removing



51110W and 51130W

For High-Flow Fuel Dispensers
Extended Life Water Sensing

Note: Will NOT Sense Water in Ethanol Blended Fuel

FOR DISPOSAL INFORMATION PLEASE CONTACT YOUR NEAREST EPA OFFICE.

Specifications

- The PetroClear® model 51110W utilizes a 10 micron (nominal) cellulose super absorbent media to remove particulate and sense water in neat gasoline, Diesel fuels, Biodiesel and ULSD (Ultra Low Sulfur Diesel), kerosene, lube oils, fuel oils, and synthetic fluids. Removes particulate 10 microns (nominal) or larger.
- The PetroClear® model 51130W utilizes a 30 micron (nominal) cellulose super absorbent media to remove particulate and sense water in neat gasoline, Diesel fuels, Biodiesel, ULSD (Ultra Low Sulfur Diesel), kerosene, lube oils, fuel oils, and synthetic fluids. Removes particulate 30 microns (nominal) or larger.
- The maximum flow rate for PetroClear® models 51110W and 51130W is 40 gpm (151 lpm). Maximum operating pressure is 50 psid (3.4 bar). Collapse pressure is 150 psid (10.3 bar). Maximum operating temperature is 250°F (139°C).
- PetroClear® models 51110W and 51130W utilize a standard 1.5"-16 UNF mounting thread ref. (1" flow) required for most spin-on filter adapters used in aftermarket and/or high-flow applications.
- Adapters are available for models 51110W and 51130W in aluminum. These adapters are available in both NPT and BSP inlet/outlet threads. Inlet/outlet sizes are available in 1" and 1-1/2" single adapters. Adapters are also available in a dual style with both 1.5" and 2" inlet/outlet (2"- 4" bolt SAE flange combination).
- Once PetroClear® models 51110W and 51130W have absorbed 28.9 ounces (855 mil) of water from neat gasoline or diesel fuels, flow will be noticeably slow.
- Each filter is packaged with a separate gasket that will fit most standard brands of adapter filter mounting bases. Install gasket in adapter's groove by placing in groove at 3 to 4 places and then smoothing gasket between those points. Lubricate with light oil.
NOTE: Gasket does not mount on filter!

Benefits

- PetroClear® models 51110W and 51130W are particulate removing and water sensing spin-on filters designed for aftermarket, cost efficient particulate filtration of fuels at high volume fueling locations such as truck stops, card lock sites, and industrial and commercial applications.
- The 51110W and 51130W are designed to remove particulate and to sense both free and emulsified water from neat gasoline, diesel, Biodiesel, ULSD (Ultra Low Sulfur Diesel), Kerosene, fuel oils, lube oils and synthetic fluids.
- PetroClear® models 51110W and 51130W are particulate and water sensing spin-on filters. These filters are designed to sense water, both free and emulsified, and slow flow as an indicator of the presence of water in neat gasoline and diesel fuels. This filter will not sense or react to water in Ethanol blended gasoline.
- PetroClear® model 51110W filter offers efficient 10 micron (nominal) particulate removal and senses both free and emulsified water.
- PetroClear® model 51130W filter offers efficient 30 micron (nominal) particulate removal and senses both free and emulsified water.
- PetroClear® models 51110W and 51130W will not detect phase separation should it occur in Ethanol blended fuels.
- Textured paint coating helps ensure a simple, mess-free installation and removal process.

PetroClear® Filters are NOT to be used in Aviation Fuel Applications!

NOTE: If you experience frequent filter changes, it is recommended that you have fuel samples analyzed to determine the source of contamination, such as water, dirt, rust, bacteria, phase separation, etc.

511 Series

Water Sensing & Particulate Removing

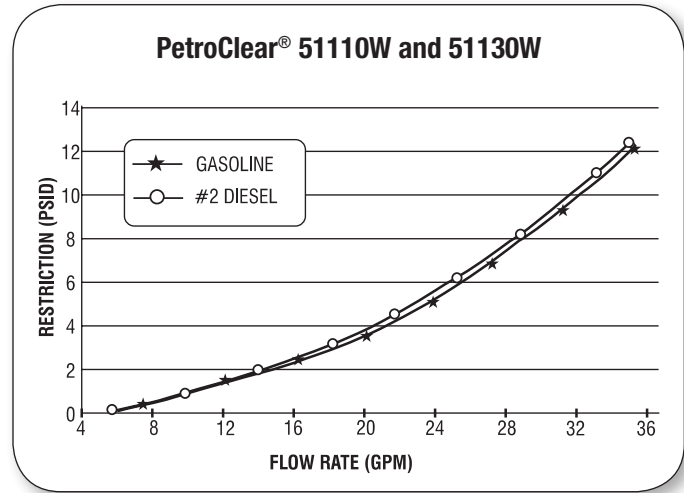
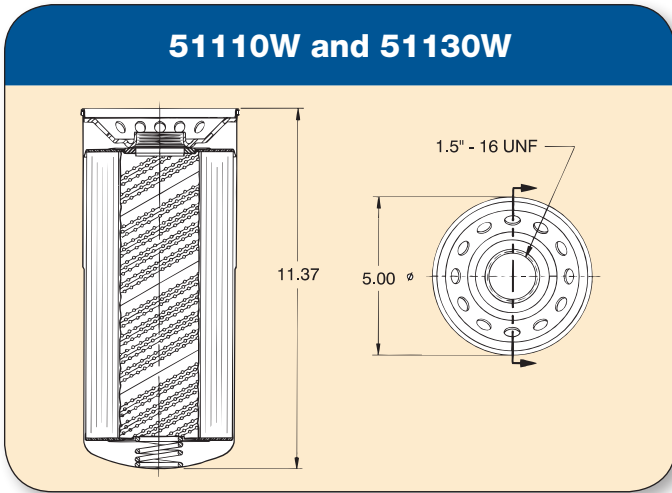

Model	51110W	51130W
Filter Type	Spin-On	Spin-On
Media Type	*Cellulose Super Absorbent Media	* Cellulose Super Absorbent Media
Micron Rating	10 Micron (nominal)	30 Micron (nominal)
Diameter	5.00"	5.00"
Height	11.37"	11.37"
Mounting Thread	1.5" -16 UNF	1.5" -16 UNF
Flow Rate	40 gpm (151 lpm)	40 gpm (151 lpm)
Flow	1" flow	1" flow
Shell Thickness	0.020	0.020
Gasket Material	Buna N	Buna N
Collapse (Min.)	150 psid (10.3 bar)	150 psid (10.3 bar)
Burst (Min.)	250 psi (17.2 bar)	250 psi (17.2 bar)
Max. Operating Temp.	250°F (139°C)	250°F (139°C)

*Particulate Removing and Water Sensing

Available Adapters

Part/Model Number	Description
1.00N1.5-16	1" NPT Inlet/Outlet Ports, 1.5" - 16 UNF (aluminum)
1.00B1.5-16	1" BSP Inlet/Outlet Ports, 1.5" - 16 UNF (aluminum)
1.25N1.5-16A	1-1/4" NPT Inlet/Outlet Ports, 1.5" - 16 UNF (aluminum)
1.50N1.5-16	1-1/2" NPT Inlet/Outlet Ports, 1.5" - 16 UNF (aluminum)
1.5B1.5-16ADA	1.5" BSP Inlet/Outlet Ports, 1.5" - 16 UNF (aluminum)
D1.5B1.5-16	1.5" BSP Inlet/Outlet Ports, 1.5" - 16 UNF (aluminum)
D2.0 N1.5-16*	2" NPT Inlet/Outlet Ports, 1.5" - 16 UNF (aluminum)

*The 4-bolt SAE flange combination allows both 1-1/2" & 2" inlet/outlet combinations.

405 Series

Agricultural Application Particulate Removing



40510PA and 40530PA
Agricultural

FOR DISPOSAL INFORMATION PLEASE CONTACT YOUR NEAREST EPA OFFICE.

Specifications

- The PetroClear® model 40510PA utilizes a 10 micron (nominal) cellulose media to remove particulate from gasolines and diesel fuels including Ethanol blended gasoline, Biodiesel and ULSD (Ultra Low Sulfur Diesel). Removes particulate 10 microns (nominal) or larger.
- The PetroClear® model 40530PA utilizes a 30 micron (nominal) cellulose media to remove particulate from gasolines and diesel fuels including Ethanol blended gasoline, Biodiesel and ULSD (Ultra Low Sulfur Diesel). Removes particulate 30 microns (nominal) or larger.
- The maximum flow rate for PetroClear® models 40510PA and 40530PA is 25 gpm (94.6 lpm). Maximum operating pressure is 50 psid (3.4 bar). Collapse pressure is 150 psid (10.3 bar). Maximum operating temperature is 250°F (139°C).
- PetroClear® models 40510PA and 40530PA utilize a standard 1.375"-12 UNF mounting thread ref. (1" flow) required for most spin-on filter Adapters used in aftermarket and agricultural applications.
- Models 40510PA and 40530PA utilize an epoxy coated interior shell to eliminate oxidation (rusting) which can cause pinhole leaks from the inside.
- Adapters are available for models 40510PA and 40530PA in cast iron. These single Adapters are available in 1" NPT inlet/outlet threads.

Benefits

- PetroClear® models 40510PA and 40530PA are particulate removing spin-on filters designed for aftermarket use on a variety of applications from power pumps and agricultural applications as well as, commercial and industrial applications.
- Designed to remove particulate from fuels, Ethanol blended gasolines, diesels, Biodiesel, ULSD (Ultra Low Sulfur Diesel), kerosene and fuel oils.
- PetroClear® models 40510PA and 40530PA are particulate spin-on filters. These filters are designed for particulate removal only and WILL NOT REACT TO WATER IN FUELS OR PHASE SEPARATION IN ETHANOL BLENDED GASOLINE TO SLOW FLOW.
- PetroClear® model 40510PA filter offers efficient 10 micron (nominal) particulate removal.
- PetroClear® model 40530PA filter offers efficient 30 micron (nominal) particulate removal.
- Compatible with Gasoline, Diesel, Kerosene, Fuel Oils, Ethanol blended fuels and Biodiesel fuels.

PetroClear® Filters are NOT to be used in Aviation Fuel Applications!

NOTE: If you experience frequent filter changes, it is recommended that you have fuel samples analyzed to determine the source of contamination, such as water, dirt, rust, bacteria, phase separation, etc.

40510PA and 40530PA

Agricultural

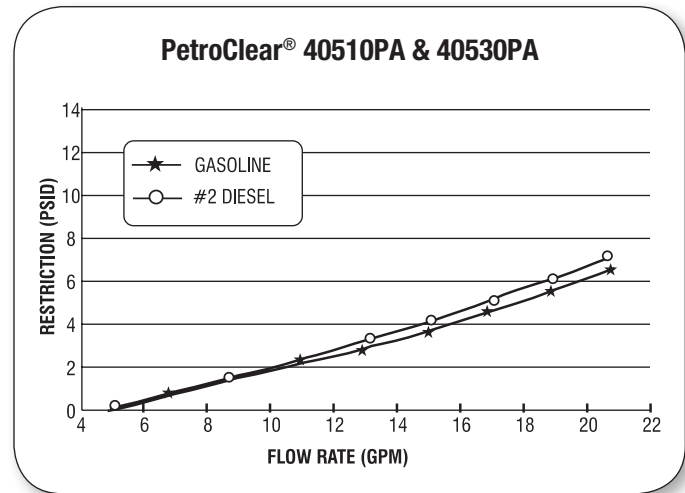
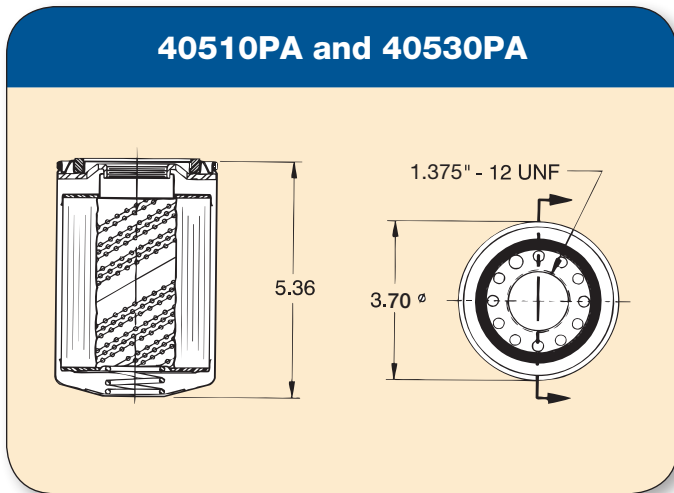

Model	40510PA	40530PA
Filter Type	Spin-On	Spin-On
Media Type	*Cellulose	* Cellulose
Micron Rating	10 Micron (nominal)	30 Micron (nominal)
Diameter	3.70"	3.70"
Height	5.36"	5.36"
Mounting Thread	1.375" - 12 UNF	1.375" - 12 UNF
Flow Rate	25 gpm (94.6 lpm)	25 gpm (94.6 lpm)
Flow	1" flow	1" flow
Shell Thickness	0.020	0.020
Gasket Material	Buna N	Buna N
Collapse (Min.)	150 psid (10.3 bar)	150 psid (10.3 bar)
Burst (Min.)	250 psi (17.2 bar)	250 psi (17.2 bar)
Max. Operating Temp.	250°F (139°C)	250°F (139°C)

*Particulate Removing

Available Adapters

Part/Model Number	Description
1.00N13/8-12	1" NPT Inlet/Outlet Ports, 1.375"-12 UNF (cast iron)

405 SERIES

Agricultural Application Particulate Removing & Water Sensing



40510WA and 40530WA
Water Sensing Agricultural
Water Sensing in Neat Gasoline and Diesels

FOR DISPOSAL INFORMATION PLEASE CONTACT YOUR NEAREST EPA OFFICE.

Specifications

- The PetroClear® model 40510WA utilizes a 10 micron (nominal) cellulose media to remove particulate from gasolines and diesel fuels including Biodiesel and ULSD (Ultra Low Sulfur Diesel). Removes particulate 10 microns (nominal) or larger. It utilizes a super absorbent media that is laminated to the filter media for water sensing capabilities in neat gasoline and diesel fuels.
- The PetroClear® model 40530WA utilizes a 30 micron (nominal) cellulose media to remove particulate from gasolines and diesel fuels including Biodiesel and ULSD (Ultra Low Sulfur Diesel). Removes particulate 30 microns (nominal) or larger. It utilizes a super absorbent media that is laminated to the filter media for water sensing capabilities in neat gasoline and diesel fuels.
- Once PetroClear® models 40510WA and 40530WA have absorbed 5.9 ounces (175 mil) of water in neat gasoline or diesel fuels, flow will be slow and will be noticeable.
- The maximum flow rate for PetroClear® models 40510WA and 40530WA is 25 gpm (94.6 lpm). Maximum operating pressure is 50 psid (3.4 bar). Collapse pressure is 150 psid (10.3 bar). Maximum operating temperature is 250°F (139°C).
- PetroClear® models 40510WA and 40530WA utilize a standard 1.375" – 12 UNF mounting thread ref. (1" flow) required for most spin-on filter Adapters used in agricultural applications.
- PetroClear® models 40510WA and 40530WA utilize an epoxy coated interior shell to eliminate oxidation (rusting) that can cause pinhole leaks from the inside of the filter shell.
- Adapters are available for models 40510WA and 40530WA in cast iron. These single Adapters are available in 1" NPT inlet/outlet threads.

Benefits

- PetroClear® models 40510WA and 40530WA are particulate removing and water sensing spin-on filters designed to remove particulate and to sense both free and emulsified water from neat gasoline, diesel, Biodiesel, ULSD (Ultra Low Sulfur Diesel), kerosene and fuel oils.
- PetroClear® models 40510WA and 40530WA are particulate and water sensing spin-on filters. These filters are designed to sense water, both free and emulsified, and slow flow as an indicator of the presence of water in neat gasoline. **THIS FILTER WILL NOT DETECT OR REACT TO WATER IN ETHANOL BLENDED GASOLINE.** (A reaction known as phase separation)
- PetroClear® model 40510WA filter offers efficient 10 micron (nominal) particulate removal and senses both free and emulsified water in neat gasoline and diesel fuels.
- PetroClear® model 40530WA filter offers efficient 30 micron (nominal) particulate removal and senses both free and emulsified water in neat gasoline and diesel fuels.
- Will not detect phase separation in Ethanol blended fuels.
- Textured paint coating helps ensure a simple, mess-free installation and removal process.

PetroClear® Filters are NOT to be used in Aviation Fuel Applications!

40510WA and 40530WA

For Fuel Dispensers

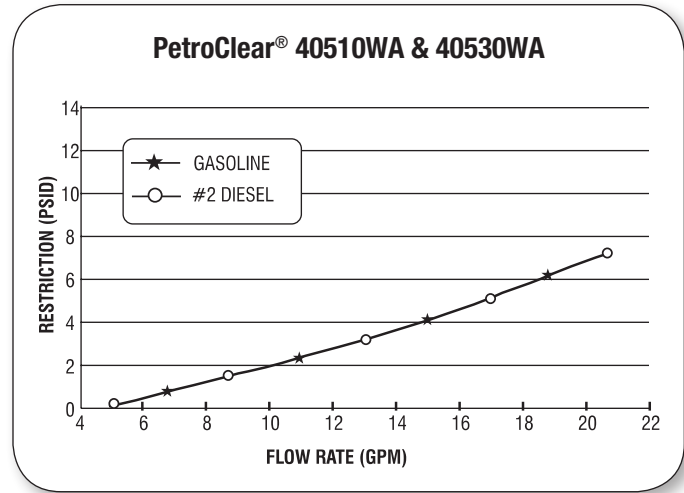
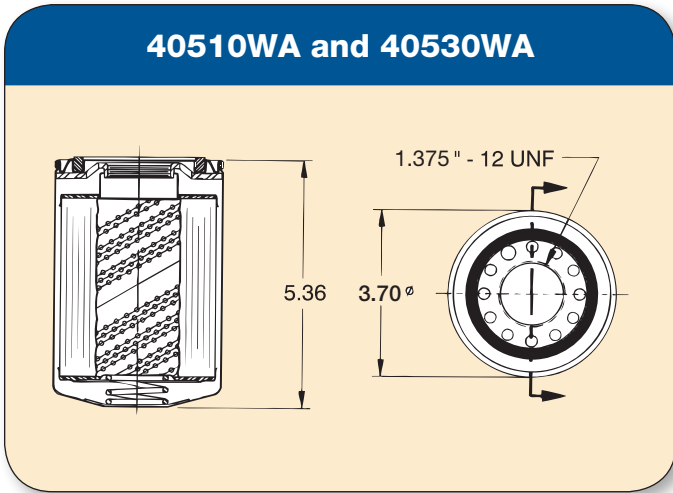

Model	40510WA	40530WA
Filter Type	Spin-On	Spin-On
Media Type	*Cellulose with Super Absorbent Media	*Cellulose with Super Absorbent Media
Micron Rating	10 Micron (nominal)	30 Micron (nominal)
Diameter	3.70"	3.70"
Height	5.36"	5.36"
Mounting Thread	1.375" - 12 UNF	1.375" - 12 UNF
Flow Rate	25 gpm (94.6 lpm)	25 gpm (94.6 lpm)
Flow	1" flow	1" flow
Shell Thickness	0.020	0.020
Gasket Material	Buna N	Buna N
Collapse (Min.)	150 psid (10.3 bar)	150 psid (10.3 bar)
Burst (Min.)	250 psi (17.2 bar)	250 psi (17.2 bar)
Max. Operating Temp.	250°F (139°C)	250°F (139°C)

*Water Sensing & Particulate Removing

Available Adapters

Part/Model Number	Description
1.00N13/8-12	1" NPT Inlet/Outlet Ports, 1.375" -12 UNF (cast iron)

408 SERIES

Particulate Removing Agricultural with Drain Valve



40810PA-DV & 40830PA-DV

Agriculture with Petcock Type Drain Valve
(Not for Commercial Dispenser Use)

FOR DISPOSAL INFORMATION PLEASE CONTACT YOUR NEAREST EPA OFFICE.

Specifications

- The PetroClear® model 40810PA-DV utilizes a 10 micron (nominal) cellulose media to remove particulate from gasoline and diesel fuels including Ethanol blended gasolines, Biodiesel and ULSD (Ultra Low Sulfur Diesel). Removes particulate 10 microns (nominal) or larger.
- The PetroClear® model 40830PA-DV utilizes a 30 micron (nominal) cellulose media to remove particulate from gasoline and diesel fuels including Ethanol blended gasolines, Biodiesel and ULSD (Ultra Low Sulfur Diesel). Removes particulate 30 microns (nominal) or larger.
- The maximum flow rate for PetroClear® models 40810PA-DV and 40830PA-DV is 25 gpm (94.6 lpm). Maximum operating pressure is 50 psid (3.4 bar). Collapse pressure is 150 psid (10.3 bar). Maximum operating temperature is 250°F (139°C).
- PetroClear® models 40810PA-DV and 40830PA-DV utilize a standard 1.375"-12 UNF mounting thread ref. (1" flow) required for most spin-on filter Adapters used in aftermarket and agricultural applications.
- Models 40810PA-DV and 40830PA-DV utilize a silicone treated media that repels water from fuel and prevents the water from passing through the filter into consumers' vehicles. The water settles to the dome end of PetroClear® models 40810PA-DV and 40830PA-DV. A petcock type drain valve located in the bottom of the filters permits convenient drainage of collected water.
- Adapters are available for models 40810PA-DV and 40830PA-DV in cast iron. These single Adapters are available in 1" NPT inlet/outlet threads.

Benefits

- PetroClear® models 40810PA-DV and 40830PA-DV are particulate removing spin-on filters designed for aftermarket cost efficient particulate filtration from gasoline, Ethanol blended gasolines, diesels, Biodiesel, ULSD (Ultra Low Sulfur Diesel), Kerosene and fuel oils.
- PetroClear® models 40810PA-DV and 40830PA-DV are particulate spin-on filters. These filters are designed for particulate only and WILL NOT REACT TO WATER IN GASOLINE OR DIESEL FUEL OR TO PHASE SEPARATION IN ALCOHOL BLENDED GASOLINES BY SLOWING FLOW.
- PetroClear® model 40810PA-DV filter offers efficient 10 micron (nominal) particulate removal.
- PetroClear® model 40830PA-DV filter offers efficient 30 micron (nominal) particulate removal.
- Compatible with all alcohol and non-alcohol blended fuels and all types of diesels.
- Not approved for use on retail fuel dispensers.

PetroClear® Filters are NOT to be used in Aviation Fuel Applications!

NOTE: If you experience frequent filter changes, it is recommended that you have fuel samples analyzed to determine the source of contamination, such as water, dirt, rust, bacteria, phase separation, etc.

40810PA-DV and 40830PA-DV

Agriculture with Petcock Type Drain Valve

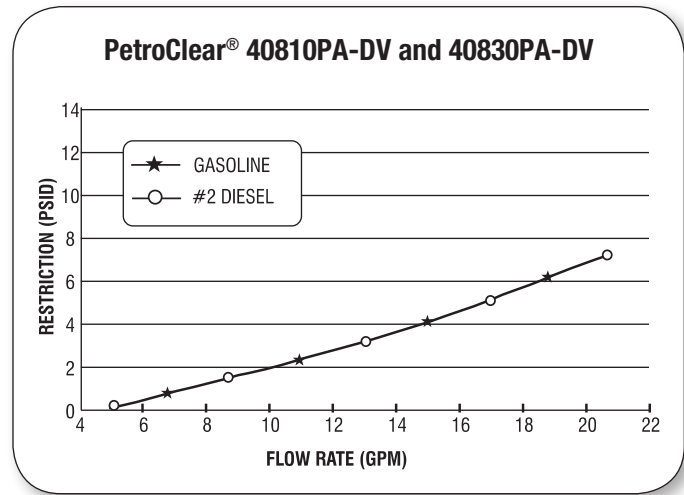
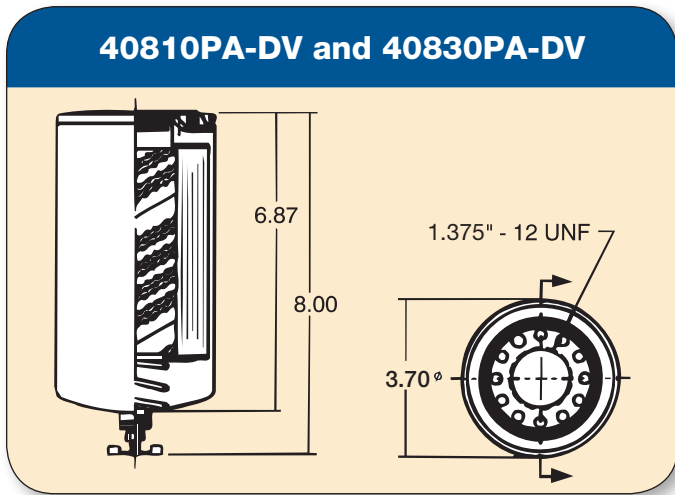

Model	40810PA-DV	40830PA-DV
Filter Type	Spin-On	Spin-On
Media Type	*Cellulose with Silicone Treatment	*Cellulose with Silicone Treatment
Micron Rating	10 Micron (nominal)	30 Micron (nominal)
Diameter	3.70"	3.70"
Height	6.87"	6.87"
Mounting Thread	1.375" - 12 UNF	1.375" - 12 UNF
Flow Rate	25 gpm (94.6 lpm)	25 gpm (94.6 lpm)
Flow	1" flow	1" flow
Shell Thickness	0.020	0.020
Gasket Material	Buna N	Buna N
Collapse (Min.)	150 psid (10.3 bar)	150 psid (10.3 bar)
Burst (Min.)	250 psi (17.2 bar)	250 psi (17.2 bar)
Max. Operating Temp.	250°F (139°C)	250°F (139°C)

*Silicone Treated & Particulate Removing

Available Adapters

Part/Model Number	Description
1.00N13/8-12	1" NPT Inlet/Outlet Ports, 1.375" -12 UNF (cast iron)

409 SERIES

Agricultural Water Sensing & Particulate Removing



40910WA and 40930WA

Extended Life Water Sensing Agricultural Water Sensing in Neat Gasoline and Diesels

FOR DISPOSAL INFORMATION PLEASE CONTACT YOUR NEAREST EPA OFFICE.

Benefits

- PetroClear® models 40910WA and 40930WA are particulate removing and water sensing spin-on filters designed to remove particulate and to sense both free and emulsified water from neat gasoline, diesel, Biodiesel, ULSD (Ultra Low Sulfur Diesel), kerosene and fuel oils.
- PetroClear® models 40910WA and 40930WA are particulate and water sensing spin-on filters. These filters are designed to sense water, both free and emulsified, and slow flow as an indicator of the presence of water in neat gasoline and diesel fuels. This filter will not sense nor react to water in Ethanol blended gasoline. (Reaction known as phase separation)
- PetroClear® model 40910WA filter offers efficient 10 micron (nominal) particulate removal and senses both free and emulsified water in neat gasoline and diesel fuel.
- PetroClear® model 40930WA filter offers efficient 30 micron (nominal) particulate removal and senses both free and emulsified water in neat gasoline and diesel fuel.
- Will not detect phase separation in Ethanol blended fuels.
- Compatible with Biodiesel, Kerosene, Fuel Oil, ULSD (Ultra Low Sulfur Diesel), and Diesel fuels.
- Textured paint coating helps ensure a simple, mess-free installation and removal process.

PetroClear® Filters are NOT to be used in Aviation Fuel Applications!

Specifications

- The PetroClear® model 40910WA utilizes a 10 micron (nominal) cellulose media to remove particulate from gasolines and diesel fuels including Biodiesel and ULSD (Ultra Low Sulfur Diesel). Removes particulate 10 microns (nominal) or larger, and utilizes a super absorbent media that is laminated to the filter media for water sensing capabilities in neat gasoline and diesel fuel.
- The PetroClear® model 40930WA utilizes a 30 micron (nominal) cellulose media to remove particulate from gasolines and diesel fuels including Biodiesel and ULSD (Ultra Low Sulfur Diesel). Removes particulate 30 microns (nominal) or larger, and utilizes a super absorbent media that is laminated to the filter media for water sensing capabilities in neat gasoline and diesel fuel.
- Once PetroClear® models 40910WA and 40930WA have absorbed 10.7 ounces (315 mil) of water from neat gasoline or diesel fuel, flow will be noticeably slow.
- The maximum flow rate for PetroClear® models 40910WA and 40930WA is 25 gpm (94.6 lpm). Maximum operating pressure is 50 psid (3.4 bar). Collapse pressure is 150 psid (10.3 bar). Maximum operating temperature is 250°F (139°C).
- PetroClear® models 40910WA and 40930WA utilize a standard 1.375"-12 UNF mounting thread ref. (1" flow) required for most spin-on filter adapters used in aftermarket and agricultural applications.
- PetroClear® models 40910WA and 40930WA utilize an epoxy coated interior shell to eliminate oxidation (rusting), which can cause pinhole leaks from the inside of the filter shell.
- Adapters are available for models 40910WA and 40930WA in cast iron. These single adapters are available in 1" NPT inlet/outlet thread.

NOTE: If you experience frequent filter changes, it is recommended that you have fuel samples analyzed to determine the source of contamination, such as water, dirt, rust, bacteria, phase separation, etc.

40910WA AND 40930WA

Agricultural

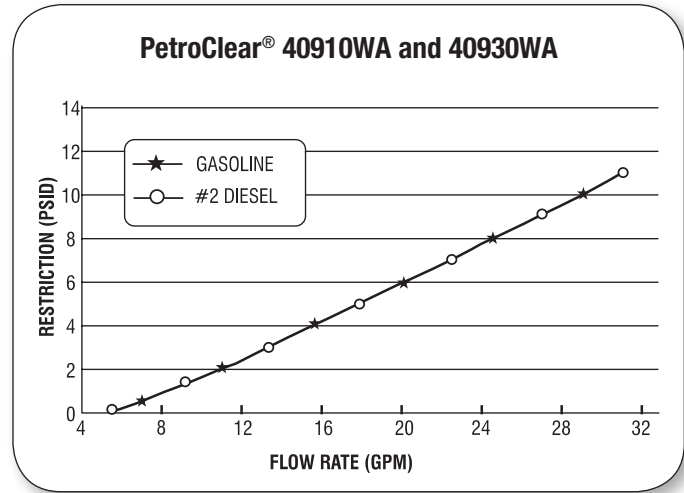
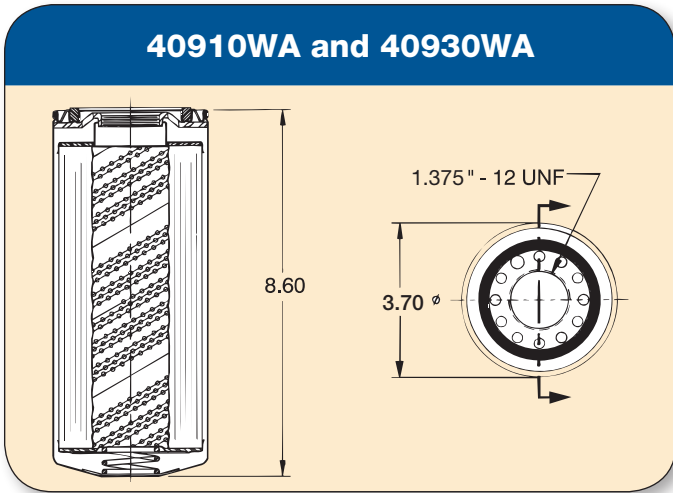

Model	40910WA	40930WA
Filter Type	Spin-On	Spin-On
Media Type	*Cellulose with Super Absorbent Media	*Cellulose with Super Absorbent Media
Micron Rating	10 Micron (nominal)	30 Micron (nominal)
Diameter	3.70"	3.70"
Height	8.60"	8.60"
Mounting Thread	1.375" – 12 UNF	1.375" – 12 UNF
Flow Rate	25 gpm (94.6 lpm)	25 gpm (94.6 lpm)
Flow	1" flow	1" flow
Shell Thickness	0.020	0.020
Gasket Material	Buna N	Buna N
Collapse (Min.)	150 psid (10.3 bar)	150 psid (10.3 bar)
Burst (Min.)	250 psi (17.2 bar)	250 psi (17.2 bar)
Max. Operating Temp.	250°F (139°C)	250°F (139°C)

*Water Sensing & Particulate Removing

Available Adapters

Part/Model Number	Description
1.00N13/8-12	1" NPT Inlet/Outlet Ports, 1.375" –12 UNF (cast iron)

E Series

Particulate Removing



PCP-E10 and PCP-E30
Replacement Element

FOR DISPOSAL INFORMATION PLEASE CONTACT YOUR NEAREST EPA OFFICE.

Specifications

- PetroClear® model PCP-E10 utilizes a 10 micron (nominal) cellulose media to remove particulate from gasoline and diesel fuels including Ethanol blended gasoline, Biodiesel, ULSD (Ultra Low Sulfur Diesel), Kerosene, fuel oils and synthetic fluids. Removes particulate 10 microns (nominal) or larger.
- PetroClear® model PCP-E30 utilizes a 30 micron (nominal) cellulose media to remove particulate from gasoline and diesel fuels including Ethanol blended gasoline, Biodiesel, ULSD (Ultra Low Sulfur Diesel), Kerosene, fuel oils and synthetic fluids. Removes particulate 30 microns (nominal) or larger.
- The maximum flow rate for PetroClear® models PCP-E10 and PCP-E30 is 30 gpm (114 lpm). Maximum operating pressure is 50 psid (3.4 bar). Collapse pressure is 150 psid (10.3 bar). Maximum operating temperature is 250°F (139°C).
- PetroClear® models PCP-E10 and PCP-E30 replacement elements fit the Cim-Tek® Centurion Series housings and other brands with a 5" x 9" element.

Benefits

- PetroClear® models PCP-E10 and PCP-E30 are particulate removing replacement element type filters designed for aftermarket, cost efficient particulate filtration of fuels at high volume fueling locations such as truck stops, card lock sites, and industrial and commercial applications.
- PetroClear® models PCP-E10 and PCP-E30 are particulate removing replacement element type filters designed to remove particulate from neat gasoline, Ethanol blended gasoline, diesel, Biodiesel, ULSD (Ultra Low Sulfur Diesel), Kerosene, fuel oils, lube oils and synthetic fluids.
- PetroClear® models PCP-E10 and PCP-E30 are particulate replacement element type filters. These filters are designed for particulate removal only and WILL NOT REACT TO WATER IN NEAT GASOLINE OR DETECT PHASE SEPARATION IN ETHANOL BLENDED GASOLINE.
- PetroClear® model PCP-E10 filter offers efficient 10 micron (nominal) particulate removal.
- PetroClear® model PCP-E30 filter offers efficient 30 micron (nominal) particulate removal.

PetroClear® Filters are NOT to be used in Aviation Fuel Applications!

NOTE: If you experience frequent filter changes, it is recommended that you have fuel samples analyzed to determine the source of contamination, such as water, dirt, rust, bacteria, phase separation, etc.

E Series

Particulate Removing

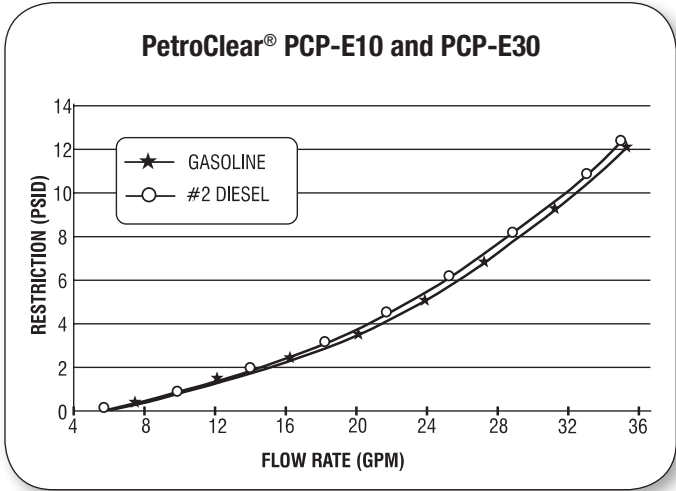
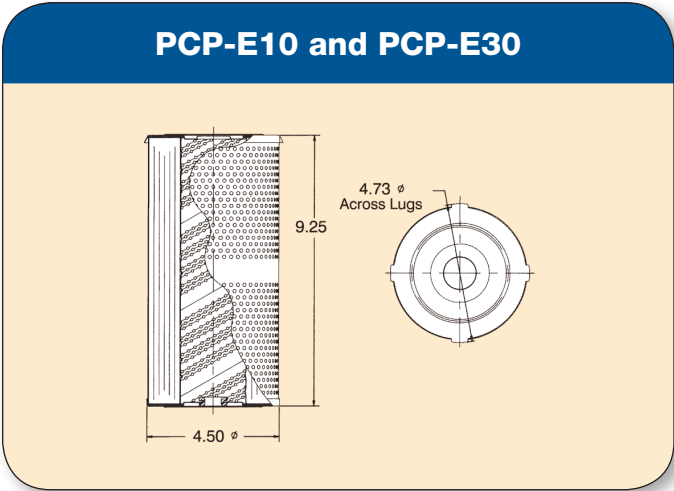

Model	PCP-E10	PCP-E30
Filter Type	Element	Element
Media Type	*Cellulose	*Cellulose
Micron Rating	10 Micron (nominal)	30 Micron (nominal)
Diameter	4.50"	4.50"
Height	9.25"	9.25"
Flow Rate	30 gpm (114 lpm)	30 gpm (114 lpm)
Gasket Material	Buna N	Buna N
Collapse (Min.)	150 psid (10.3 bar)	150 psid (10.3 bar)
Max. Operating Temp.	250°F (139°C)	250°F (139°C)

*Particulate Removing

E Series

Water Sensing & Particulate Removing



PCW-E10 and PCW-E30
Replacement Element

FOR DISPOSAL INFORMATION PLEASE CONTACT YOUR NEAREST EPA OFFICE.

Specifications

- The PetroClear® model PCW-E10 utilizes a 10 micron (nominal) cellulose super absorbent media to remove particulate and sense water in neat gasoline, Diesel fuels, Biodiesel and ULSD (Ultra Low Sulfur Diesel), kerosene, lube oils, fuel oils, and synthetic fluids. Removes particulate 10 microns (nominal) or larger.
- The PetroClear® model PCW-E30 utilizes a 30 micron (nominal) cellulose super absorbent media to remove particulate and sense water in neat gasoline, Diesel fuels, Biodiesel, ULSD (Ultra Low Sulfur Diesel), kerosene, lube oils, fuel oils, and synthetic fluids. Removes particulate 30 microns (nominal) or larger.
- The maximum flow rate for PetroClear® models PCW-E10 and PCW-E30 is 30 gpm (114 lpm). Maximum operating pressure is 50 psid (3.4 bar). Collapse pressure is 150 psid (10.3 bar). Maximum operating temperature is 250°F (139°C).
- PetroClear® models PCW-E10 and PCW-E30 replacement elements fit the Cim-Tek® Centurion Series housings and other brands with a 5" x 9" element.

Benefits

- PetroClear® models PCW-E10 and PCW-E30 are particulate removing and water sensing replacement element type filters designed for aftermarket, cost efficient particulate filtration of fuels at high volume fueling locations such as truck stops, card lock sites, and industrial and commercial applications.
- The PCW-E10 and PCW-E30 are designed to remove particulate and to sense both free and emulsified water from neat gasoline, diesel, Biodiesel, ULSD (Ultra Low Sulfur Diesel), Kerosene and fuel oils.
- PetroClear® models PCW-E10 and PCW-E30 are particulate and water sensing replacement element type filters. These filters are designed to sense water, both free and emulsified, and slow flow as an indicator of the presence of water in neat gasoline. This filter will not sense or react to water in Ethanol blended fuels.
- PetroClear® models PCW-E10 and PCW-E30 will not detect phase separation should it occur in Ethanol blended fuels.
- PetroClear® model PCE-E-10 Filter offers efficient 10 micron (nominal) particulate removal with water sensing.
- PetroClear® model PCW-E30 Filter offers efficient 30 micron (nominal) particulate removal with water sensing.

PetroClear® Filters are NOT to be used in Aviation Fuel Applications!

NOTE: If you experience frequent filter changes, it is recommended that you have fuel samples analyzed to determine the source of contamination, such as water, dirt, rust, bacteria, phase separation, etc.

PCW-E10 and PCW-E30

For Aftermarket Fueling Applications

PCW-E10 and PCW-E30

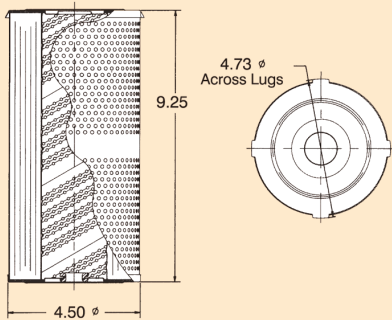

PCW-E10 and PCW-E30

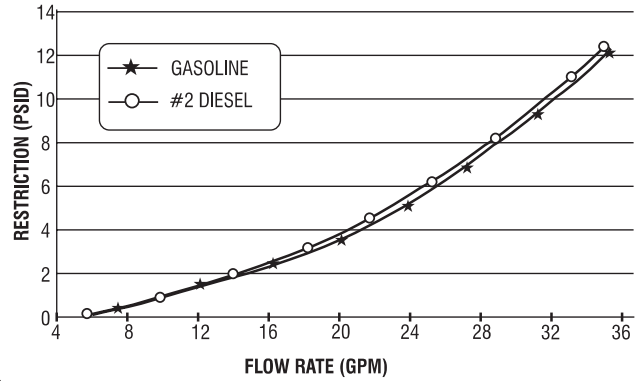

Model	PCW-E10	PCW-E30
Filter Type	Element	Element
Media Type	*Cellulose with Super Absorbent Media	*Cellulose with Super Absorbent Media
Micron Rating	10 Micron (nominal)	30 Micron (nominal)
Diameter	4.50"	4.50"
Height	9.25"	9.25"
Flow Rate	30 gpm (114 lpm)	30 gpm (114 lpm)
Gasket Material	Buna N	Buna N
Collapse (Min.)	150 psid (10.3 bar)	150 psid (10.3 bar)
Max. Operating Temp.	250°F (139°C)	250°F (139°C)

*Water Sensing in Neat Gasoline and Particulate Removing

618 Series

Particulate Removing



61810EP and 61830EP
Replacement Element

FOR DISPOSAL INFORMATION PLEASE CONTACT YOUR NEAREST EPA OFFICE.

Specifications

- PetroClear® model 61810EP utilizes a 10 micron (nominal) cellulose media to remove particulate from gasoline and diesel fuels including Ethanol blended gasoline, Biodiesel, ULSD (Ultra Low Sulfur Diesel), Kerosene, fuel oils and synthetic fluids. Removes particulate 10 microns (nominal) or larger.
- PetroClear® model 61830EP utilizes a 30 micron (nominal) cellulose media to remove particulate from gasoline and diesel fuels including Ethanol blended gasoline, Biodiesel, ULSD (Ultra Low Sulfur Diesel), Kerosene, fuel oils and sythetic fluids. Removes particulate 30 microns (nominal) or larger.
- The maximum flow rate for PetroClear® models 61810EP and 61830EP is 120 gpm (450 lpm). Maximum operating pressure is 50 psid (3.4 bar).
- PetroClear® models 61810EP and 61830EP replacement elements fit the Cim-Tek®, Commercial, Cuno, Facet, Hilco, Hycon, Hytrex, Kaydon, Nugent and Peco housings and other brands with a 6" x 18" element.

Benefits

- PetroClear® models 61810EP and 61830EP are particulate removing replacement element type filters designed to remove particulate from neat gasoline, Ethanol blended gasoline, diesel, Biodiesel, ULSD (Ultra Low Sulfur Diesel), Kerosene, fuel oils, lube oils and synthetic fluids.
- PetroClear® models 61810EP and 61830EP are particulate replacement element type filters. These filters are designed for particulate removal only and WILL NOT REACT TO WATER IN NEAT GASOLINE OR DETECT PHASE SEPARATION IN ETHANOL BLENDED GASOLINE.
- PetroClear® model 61810EP filter offers efficient 10 micron (nominal) particulate removal.
- PetroClear® model 61830EP filter offers efficient 30 micron (nominal) particulate removal.

PetroClear® Filters are NOT to be used in Aviation Fuel Applications!

NOTE: If you experience frequent filter changes, it is recommended that you have fuel samples analyzed to determine the source of contamination, such as water, dirt, rust, bacteria, phase separation, etc.

61810EP and 61830EP Industrial Replacement Cartridges

61810EP and 61830EP

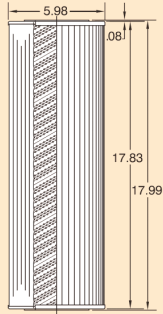

61810EP and 61830EP

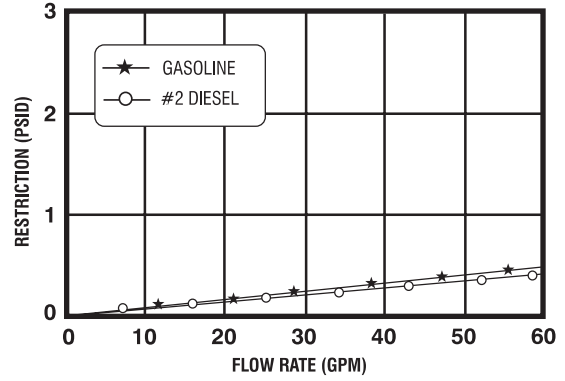

Model	61810EP	61830EP
Filter Type	Element	Element
Media Type	*Cellulose	*Cellulose
Micron Rating	10 Micron (nominal)	30 Micron (nominal)
Diameter	5.98"	5.98"
Height	17.99"	17.99"
Flow Rate	120 gpm (405 lpm)	120 gpm (405 lpm)
Gasket Material	Buna N	Buna N
Collapse (Min.)	150 psid (10.3 bar)	150 psid (10.3 bar)
Max. Operating Temp.	250°F (139°C)	250°F (139°C)

*Particulate Removing

618 Series

Water Sensing & Particulate Removing



61805EW, 61810EW and 61830EW

Industrial Replacement Element

FOR DISPOSAL INFORMATION PLEASE CONTACT YOUR NEAREST EPA OFFICE.

Specifications

- The PetroClear® model 61805EW utilizes a 5 micron (nominal) cellulose super absorbent media to remove particulate and sense water in neat gasoline, Diesel fuels, Biodiesel and ULSD (Ultra Low Sulfur Diesel), kerosene, lube oils, fuel oils, and synthetic fluids. Removes particulate 5 microns (nominal) or larger.
- The PetroClear® model 61810EW utilizes a 10 micron (nominal) cellulose super absorbent media to remove particulate and sense water in neat gasoline, Diesel fuels, Biodiesel and ULSD (Ultra Low Sulfur Diesel), kerosene, lube oils, fuel oils, and synthetic fluids. Removes particulate 10 microns (nominal) or larger.
- The PetroClear® model 61830EW utilizes a 30 micron (nominal) cellulose super absorbent media to remove particulate and sense water in neat gasoline, Diesel fuels, Biodiesel, ULSD (Ultra Low Sulfur Diesel), kerosene, lube oils, fuel oils, and synthetic fluids. Removes particulate 30 microns (nominal) or larger.
- The maximum flow rate for PetroClear® models 61805EW, 61810EW and 61830EW is 120 gpm (450 lpm). Maximum operating pressure is 50 psid (3.4 bar).
- PetroClear® models 61805EW, 61810EW and 61830EW replacement elements fit the Cim-Tek®, Commercial, Cuno, Facet, Hilco, Hycon, Hytex, Kaydon, Nugent and Peco housings and other brands with a 6" x 18" element.

Benefits

- PetroClear® models 61805EW, 61810EW and 61830EW are particulate removing and water sensing replacement element type filters designed for aftermarket, cost efficient particulate filtration of fuels at high volume fueling locations such as truck stops, card lock sites, and industrial and commercial applications.
- The 61805EW, 61810EW and 61830EW are designed to remove particulate and to sense both free and emulsified water from neat gasoline, diesel, Biodiesel, ULSD (Ultra Low Sulfur Diesel), Kerosene and fuel oils.
- PetroClear® models 61805EW, 61810EW and 61830EW are particulate and water sensing replacement element type filters. These filters are designed to sense water, both free and emulsified, and slow flow as an indicator of the presence of water in neat gasoline. This filter will not sense or react to water in Ethanol blended gasoline.
- PetroClear® model 61805EW filter offers efficient 5 micron (nominal) particulate removal and senses both free and emulsified water.
- PetroClear® model 61810EW filter offers efficient 10 micron (nominal) particulate removal and senses both free and emulsified water.
- PetroClear® model 61830EW filter offers efficient 30 micron (nominal) particulate removal and senses both free and emulsified water.
- PetroClear® models 61805EW, 61810EW and 61830EW will not detect phase separation should it occur in Ethanol blended fuels.

PetroClear® Filters are NOT to be used in Aviation Fuel Applications!

NOTE: If you experience frequent filter changes, it is recommended that you have fuel samples analyzed to determine the source of contamination, such as water, dirt, rust, bacteria, phase separation, etc.

61805EW, 61810EW and 61830EW

Industrial Replacement Cartridges

61805EW, 61810EW and 61830EW

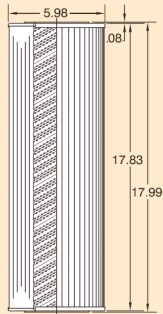

61805EW, 61810EW and 61830EW

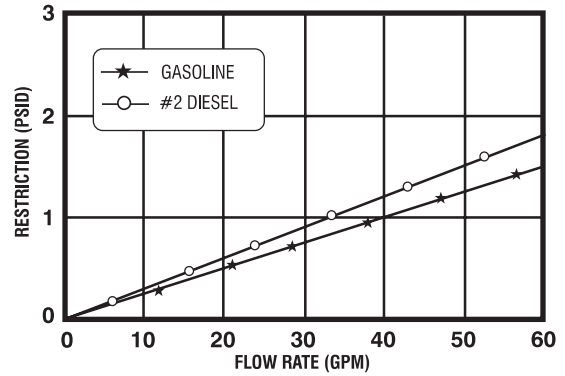

Model	61805EW	61810EW	61830EW
Filter Type	Element	Element	Element
Media Type	*Cellulose with Super Absorbent Media	*Cellulose with Super Absorbent Media	*Cellulose with Super Absorbent Media
Micron Rating	5 Micron (nominal)	10 Micron (nominal)	30 Micron (nominal)
Diameter	5.98"	5.98"	5.98"
Height	17.99"	17.99"	17.99"
Flow Rate	120 gpm (405 lpm)	120 gpm (405 lpm)	120 gpm (405 lpm)
Gasket Material	Buna N	Buna N	Buna N
Collapse (Min.)	150 psid (10.3 bar)	150 psid (10.3 bar)	150 psid (10.3 bar)
Max. Operating Temp.	250°F (139°C)	250°F (139°C)	250°F (139°C)

*Water Sensing in Neat Gasoline and Particulate Removing

DEF-E Series

Diesel Exhaust Fluid Dispenser Filter Element



DEF-E5 and DEF-E10

For Diesel Exhaust Fluid Dispensers

FOR DISPOSAL INFORMATION PLEASE CONTACT YOUR NEAREST EPA OFFICE.

Benefits

- The PetroClear® models DEF-E5 and DEF-E10 Diesel Exhaust Fluid Dispenser Filter Elements* filter urea crystals and other contaminants to prevent them from reaching a vehicle's on-board DEF filter.
- PetroClear® models DEF-E5 and DEF-E10 Diesel Exhaust Fluid Dispenser Filter Elements help prevent Selective Catalytic Reduction systems from malfunctioning while also extending the life of on-board DEF filters.
- PetroClear® model DEF-E5 Diesel Exhaust Fluid Dispenser Filter Element offers efficient 5 micron (absolute) particulate removal.
- PetroClear® model DEF-E10 Diesel Exhaust Fluid Filter Dispenser Element offers efficient 10 micron (absolute) particulate removal.
- 5.6 square feet of media surface area provides high throughput and particle retention.
- PetroClear® models DEF-E5 and DEF-E10 Diesel Exhaust Fluid Filter Dispenser Elements feature Absolute-Rated Beta 5000 (99.98%) retention efficiency.
- The PetroClear® models DEF-E5 and DEF-E10 Diesel Exhaust Fluid Dispenser Filter Elements' rigid, molded cage provides structural integrity for reliable performance.
- The PetroClear® models DEF-E5 and DEF-E10 Diesel Exhaust Fluid Filter Dispenser Elements' gradient, fixed pore structure increases dirt-holding capacity.
- PetroClear® models DEF-E5 and DEF-E10 Diesel Exhaust Fluid Filter Dispenser Elements' filter media, outer cage, core and end caps are constructed of polypropylene.
- PetroClear® models DEF-E5 and DEF-E10 Diesel Exhaust Fluid Dispenser Filter Elements includes an ethylene-propylene rubber (EPR) gasket for leak-free operation.

Specifications

- The PetroClear® model DEF-E5 Diesel Exhaust Fluid Dispenser Filter Element utilizes a 5 micron (absolute) polypropylene media to remove particulate in Diesel Exhaust Fluid.
- The PetroClear® model DEF-E10 Diesel Exhaust Fluid Dispenser Filter Element utilizes a 10 micron (absolute) polypropylene media to remove particulate in Diesel Exhaust Fluid.
- The maximum flow rate for PetroClear® models DEF-E5 and DEF-E10 Diesel Exhaust Fluid Dispenser Filter Elements is 7 GPM. The maximum differential (collapse) pressure is 75 psid at 70°F, 40 psid at 176°F.
- The maximum operating temperature is 176°F.

*The PetroClear® models DEF-HSS1.0N and DEF-HSS1.0B Diesel Exhaust Fluid Dispenser Filter Housings are sold separately.

DEF-E5 and DEF-E10

Diesel Exhaust Fluid Dispenser Filter Element

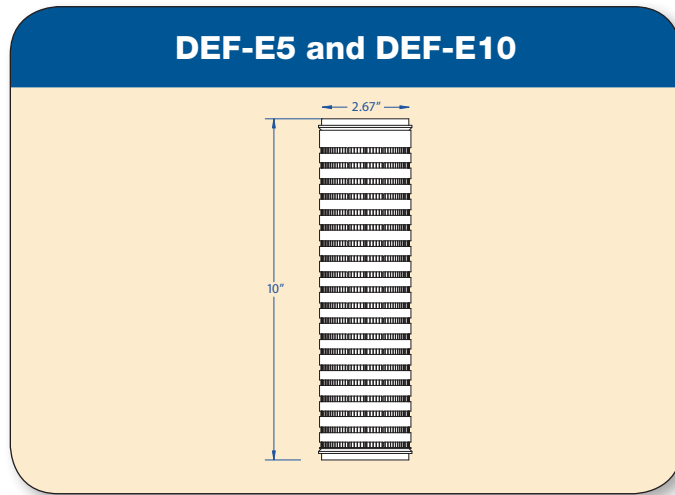

Model	DEF-E5	DEF-E10
Filter Type	Element	Element
Media Type	Polypropylene	Polypropylene
Micron Rating	5	10
Gasket Material	EPR	EPR
Diameter	2.67"	2.67"
Height	10"	10"
Flow Rate	7 GPM	7 GPM
Max. Differential (Collapse) Pressure	75 psid at 70°F, 40 psid at 176°F	75 psid at 70°F, 40 psid at 176°F
Max. Operating Temp.	176°F	176°F

PetroClear® Diesel Exhaust Fluid Dispenser Filter Housing sold separately.

DEF-H Series

Diesel Exhaust Fluid Dispenser Filter Housing



FOR DISPOSAL INFORMATION PLEASE CONTACT YOUR NEAREST EPA OFFICE.

Benefits

- PetroClear® models DEF-HSS1.0N and DEF-HSS1.0B Diesel Exhaust Fluid Dispenser Filter Housings feature heavy duty 316L stainless steel construction for maximum durability.
- 316L stainless steel offers improved resistance to corrosion in some applications.
- The PetroClear® models DEF-HSS1.0N and DEF-HSS1.0B Diesel Exhaust Fluid Dispenser Filter Housings' ring nut closure facilitates quick cartridge change-outs.
- The PetroClear® model DEF-HSS1.0N Diesel Exhaust Fluid Dispenser Filter Housing includes 1" NPT inlet/outlet connections.
- The PetroClear® model DEF-HSS1.0B Diesel Exhaust Fluid Dispenser Filter Housing includes 1" BSPT inlet/outlet connections.
- Models DEF-HSS1.0N and DEF-HSS1.0B gasket material is ethylene-propylene rubber (EPR).
- Models DEF-HSS1.0N and DEF-HSS1.0B feature spring-loaded knife edge seals that provide positive sealing for filter element*.
- Models DEF-HSS1.0N and DEF-HSS1.0B include mounting bracket kit and wrench.

Specifications

- The PetroClear® models DEF-HSS1.0N and DEF-HSS1.0B Diesel Exhaust Fluid Dispenser Filter Housings' Head/Shell are constructed of 316L stainless steel.
- The PetroClear® models DEF-HSS1.0N and DEF-HSS1.0B Diesel Exhaust Fluid Dispenser Filter Housing drains are 316L stainless steel plugs.
- The PetroClear® models DEF-HSS1.0N and DEF-HSS1.0B Diesel Exhaust Fluid Dispenser Filter Housing rings are nickel-plated brass.
- The PetroClear® models DEF-HSS1.0N and DEF-HSS1.0B Diesel Exhaust Fluid Dispenser Filter Housing gaskets are ethylene-propylene rubber (EPR).
- The maximum flow rate for PetroClear® models DEF-HSS1.0N and DEF-HSS1.0B is 7 GPM. The maximum operating pressure is 300 psid at 200°F.

* PetroClear® model DEF-E5 and DEF-E10 Diesel Exhaust Fluid Dispenser Filter Elements are sold separately.

DEF-HSS1.0N and DEF-HSS1.0B

Diesel Exhaust Fluid Dispenser Filter Housing

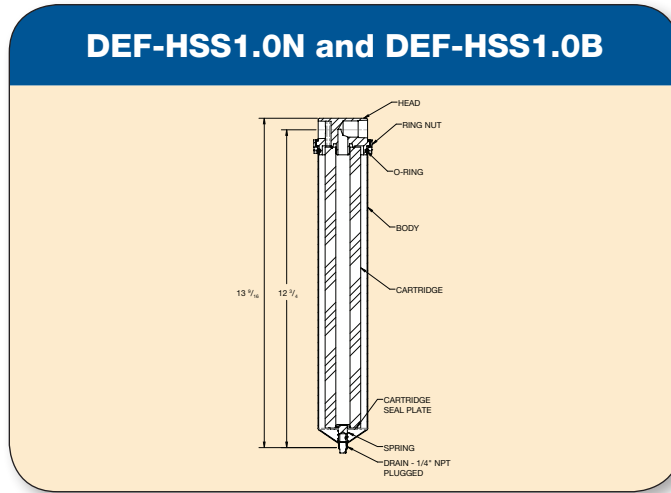

Model	DEF-HSS1.0N	DEF-HSS1.0B
Filter Type	Housing	Housing
Housing Material	316L SS	316L SS
Gasket Material	EPR	EPR
Housing Height	13 9/16"	13 9/16"
Element Height*	10"	10"
Element Diameter*	2.67"	2.67"
Connection	1" NPT	1" BSPT
Maximum Operating Pressure	300 psig at 200°F	300 psig at 200°F

PetroClear® models DEF-E5 and DEF-E10 Diesel Exhaust Fluid Dispenser Filter Element sold separately.

Tank Vent



TANK VENT TV-2
Cap and Base

FOR DISPOSAL INFORMATION PLEASE CONTACT YOUR NEAREST EPA OFFICE.

Benefits

- The PetroClear® TV-2 is designed for use on above ground storage and transfer tanks for assorted gasolines and diesels. It can also be used for small lubricant and non-pressurized hydraulic reservoirs.
- The PetroClear® TV-2 is designed to hold a constant tank pressure reducing evaporation loss, reduce contamination intake and prevent over expansion and contraction of the tank.
- Fuel temperature in a tank rises during the day causing the contents to expand creating pressure which needs to be vented before it can do damage to the tank. At night the fuel cools causing a vacuum when the contents contract pulling the tank inward. The vacuum needs to be eliminated to prevent damage to the tank. By maintaining a semi-closed system, the amount of fuel vapors that escape into the atmosphere and the amount of moisture taken into the tank are reduced.
- The PetroClear® TV-2 helps control fuel quality by keeping moisture out.
- It provides an easy opening for filling of a tank.
- Reduces the loss of fuel due to evaporation during fuel storage.
- The PetroClear® TV-2 reduces content spills in transfer reservoirs during transport by closing the system.
- The PetroClear® TV-2 provides a means for securing contents with a padlock.

Specifications

- The TV-2 Base has a 2" NPT thread that will fit most standard tank fill pipes.
- The TV-2 Cap is Zinc oxide coated to prevent rust. The cast iron base is powder coated to prevent rust.
- The TV-2 will vent at 2.5 lbs of pressure.
- The TV-2 will open at 1.5 ounces of vacuum.



Tank Vent TV-RC-2

Tank Vent Replacement Cap for TV-2

- This replacement cap fits the TV-2 base (shown above) and purchased separately.

PetroClear® is a technological product of Champion Laboratories, Inc. Changes may occur based upon technology, process and material innovation as Champion Laboratories, Inc. strives to attain the highest levels of performance and customer satisfaction. These changes may occur without notification.

07/2023 TV-2

NOTE: If you experience frequent filter changes, it is recommended that you have fuel samples analyzed to determine the source of contamination, such as water, dirt, rust, bacteria, phase separation, etc.

TC 1-12 and TC 1.5-16-AD Adapter Test Cap



Benefits

- PetroClear® Adapter Test Cap models TC 1-12 and TC 1.5-16-AD are designed to be installed on the Adapter base in place of a spin-on filter on a fuel dispenser. The Test Cap will allow service technicians to test and calibrate dispensers without the restriction or cost of a filter.
- PetroClear® model TC 1-12 is designed to fit on a filter Adapter base with a 1"-12 UNF mounting thread (3/4" flow).
- PetroClear® model TC-1.5-16-AD is designed to fit on a filter Adapter base with 1.5"-16 UNF mounting thread (1" flow). Examples: Gilbarco, Wayne, Bennet, Tokheim and other major manufacturers' dispensers.
- PetroClear® Test Caps are not designed to be permanently installed in place of a filter. The product is not warranted against failure after prolonged use.



Specifications

- PetroClear® Test Caps have a welded 1" Hex Nut on the dome end of the Test Cap to aid in both installation and removal.
- PetroClear® Test Caps are designed for a maximum operating pressure of 100 psi.
- Test Cap model TC-1-12 and TC 1.5-16-AD utilize an epoxy-coated shell to eliminate oxidation which can cause pinhole leaks from the inside.

FOR DISPOSAL INFORMATION PLEASE CONTACT YOUR NEAREST EPA OFFICE.

NOTE: If you experience frequent filter changes, it is recommended that you have fuel samples analyzed to determine the source of contamination, such as water, dirt, rust, bacteria, phase separation, etc.

TC 1-12 and TC 1.5-16-AD

Adapter Test Cap

Adapter TEST CAP TC 1-12

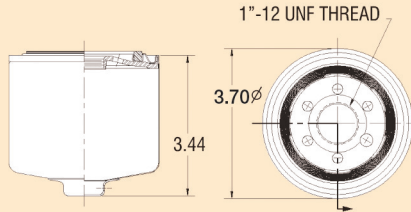

Adapter TEST CAP TC 1.5-16-AD

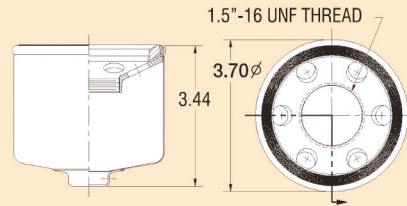

Model	TC 1-12	TC 1.5-16-AD
Filter Type	Spin-on	Spin-on
Diameter	3.70"	3.70"
Height	3.44"	3.44"
Flow	3/4" flow	1" flow
Gasket Material	Buna N	Buna N

Filter Cutter



FC 1 HD

To Allow for Inspection of Filter to Determine Type of Contamination.

FOR DISPOSAL INFORMATION PLEASE CONTACT YOUR NEAREST EPA OFFICE.

Benefits

- Easily cuts through spin-on filter shell housings. Operates on the same principle as a tubing cutter.
- Simply drain filter, remove gasket, place the filter flat on the cutter body, tighten the black knob to push the cutter wheel against the filter, then turn the filter several times and the shell will separate from mounting plate, exposing the filter element for easy inspection.
- Rollers make it easy to turn the filter.
- Constructed of heavy-duty aircraft quality aluminum and composite materials.
- The effective design ensures a straight cut.
- Cutting wheel is easily replaceable.
- Maintenance technicians know the importance of cutting a filter open and checking the media in the filter. In the past, this has been a difficult, dangerous and frustrating job to complete.
- Light weight, compact and easy to use.
- Cutting wheels are made of hardened and tempered steel.

All fluids within the filters should be emptied prior to opening the spin-on filter housing.

Specifications

- Aluminum and composite material construction eliminates oxidation (rust) and potential for sparks.
- Dimensions: 3.5" wide x 16.5" long (closed position), 20.75" (fully opened).
- Will cut open most spin-on filters ranging from 3" diameter to over 5" diameter.
- Replacement cutting wheels are available at many local hardware stores. General brand tubing cutter wheels - part number RW121/2. ID .193" x OD .725".

PetroClear® is a technological product of Champion Laboratories, Inc. Changes may occur based upon technology, process and material innovation as Champion Laboratories, Inc. strives to attain the highest levels of performance and customer satisfaction. These changes may occur without notification.

07/2023 Filter Cutter

NOTE: If you experience frequent filter changes, it is recommended that you have fuel samples analyzed to determine the source of contamination, such as water, dirt, rust, bacteria, phase separation, etc.

SALES & MARKETING Materials

PetroClear
PARTICULATE MATIÈRE PARTICULAIRE
40510P-AD

PetroClear
ETHANOL - NON-ETHANOL AVEC OU SANS ETHANOL
40510D-AD

PetroClear
WATER SENSING REACTION À L'EAU
40510W-AD

PetroClear
ETHANOL ETHANOL
40510A-AD

Clear Selection. Ultimate Protection.

Clear Selection. Ultimate Protection.

Feature Benefits

- Engineered to clean and remove particulate (dirt) from fuel
- Ability to detect and react to phase separation in ethanol blended fuel
- Available in both 10 and 30 micron ratings
- TruSeal® joint coating helps ensure a simple, snap-free installation and removal process

Customer Value

- Helps keep fuel clean in order to protect customer's vehicle from harmful contaminants
- Designed to prevent engine-damaging phase-separated fuel from being ingested into customer's vehicles
- Provides the owner the ability to detect particulate during the specific needs of their operation

Feature Benefits

- Engineered to clean and remove particulate (dirt) from fuel
- Ability to detect and react to free and emulsified water in non-ethanol blended fuel, diesel, biodiesel, ULSJ (Ultra Low Sulfur Diesel), kerosene and turpentine
- Also compatible with industrial fuels
- TruSeal® joint coating helps ensure a simple, snap-free installation and removal process

Customer Value

- Helps prevent ethanol-blended fuel that has been contaminated by water from being combusted by customer's automotive engines
- In the event water is present in non-ethanol blended fuel, the dispenser's flow will naturally allow settling action, prevent the blend from being ingested
- Filter is also able to remove particulate (dirt) and water in non-ethanol blended fuel

Feature Benefits

- Engineered to clean and remove particulate (dirt) from fuel
- Compatible with non-ethanol blended fuels, ethanol blended fuel and all blends, including biodiesel and all blends, from 2 to 30 percent
- Available in a number of micron ratings, from 2 to 30 microns
- TruSeal® joint coating helps ensure a simple, snap-free installation and removal process

Customer Value

- Helps keep fuel clean in order to protect customer's vehicle from harmful contaminants
- Offers the ability to filter multiple sizes of fuels, regardless of ethanol or ethanol content
- Helps prevent the smaller particulate from damaging engine components

Feature Benefits

- Engineered to clean and remove particulate (dirt) from fuel
- Defects and reacts to phase separation in ethanol blended fuel, and emulsified water in non-ethanol blended fuel
- This patented dual filter provides protection during the transition from non-ethanol to ethanol blends without changing filters
- TruSeal® joint coating helps ensure a simple, snap-free installation and removal process

Customer Value

- Provides dispenser the ability to remedy a variety of fuels, including both non-ethanol blended and ethanol blended fuels
- In the event water or gasoline is present in fuel, the filter will naturally allow the owner to a proper dispenser to prevent
- Designed to prevent phase-separation

PetroClear
Clear Selection. Ultimate Protection.

1-800-851-5990
PetroClear.com

Color-Coded for Quick, Easy and Accurate

Family	Ethanol Blended Gasoline or 100% Gasoline	Ethanol Blended Gasoline Only	100% Gasoline Diesel, Biodiesel
Problem(s)	Particulate (dirt), Phase Separation	Particulate (dirt), Phase Separation	Particulate (dirt)
Solution	PetroClear ETHANOL - NON-ETHANOL AVEC OU SANS ETHANOL 40510D-AD	PetroClear ETHANOL ETHANOL 40510A-AD	PetroClear WATER SENSING REACTION À L'EAU 40510W-AD
	Phase Separation Detection & Water Sensing & Particulate Removing	Phase Separation Detection "Alert" & Particulate Removing	Water Sensing & Particulate Removing

PetroClear
WATER SENSING & PARTICULATE REMOVING
40510W-AD
FUEL DISPENSER FILTER

PetroClear
ETHANOL - NON-ETHANOL AVEC OU SANS ETHANOL
40510D-AD
FUEL DISPENSER FILTER

PetroClear
ETHANOL ETHANOL
40510A-AD
FUEL DISPENSER FILTER

200 Bank Street, St. John's, New Brunswick A1B 1X6 | Tel: (506) 693-0000 | Fax: (506) 693-0008
Outside U.S.: (410) 444-0111 | Fax: Canada: (514) 444-0111 | PetroClear.com

Your Vehicle's Fuel is Protected by
PetroClear
The Last Line of Defense

NOTE: If you experience frequent filter changes, it is recommended that you have fuel samples analyzed to determine the source of contamination, such as water, dirt, rust, bacteria, phase separation, etc.

Fuel Dispenser Filters for Gilbarco®, Wayne® and other Popular Brands

PetroClear® state-of-the-art filters are available in a number of micron ratings to keep fuel clean and flowing easily.

Particulate Removing Only

Spin-on filters designed to remove particulate from neat gasoline, Ethanol blended gasoline, diesel, Biodiesel, ULSD (Ultra Low Sulfur Diesel), kerosene, fuel oils and Ethanol fuels.

Water Sensing & Particulate Removing

Spin-on filters designed to remove particulate and to sense both free and emulsified water from gasoline, diesel, Biodiesel, ULSD (Ultra Low Sulfur Diesel), Kerosene and fuel oils.

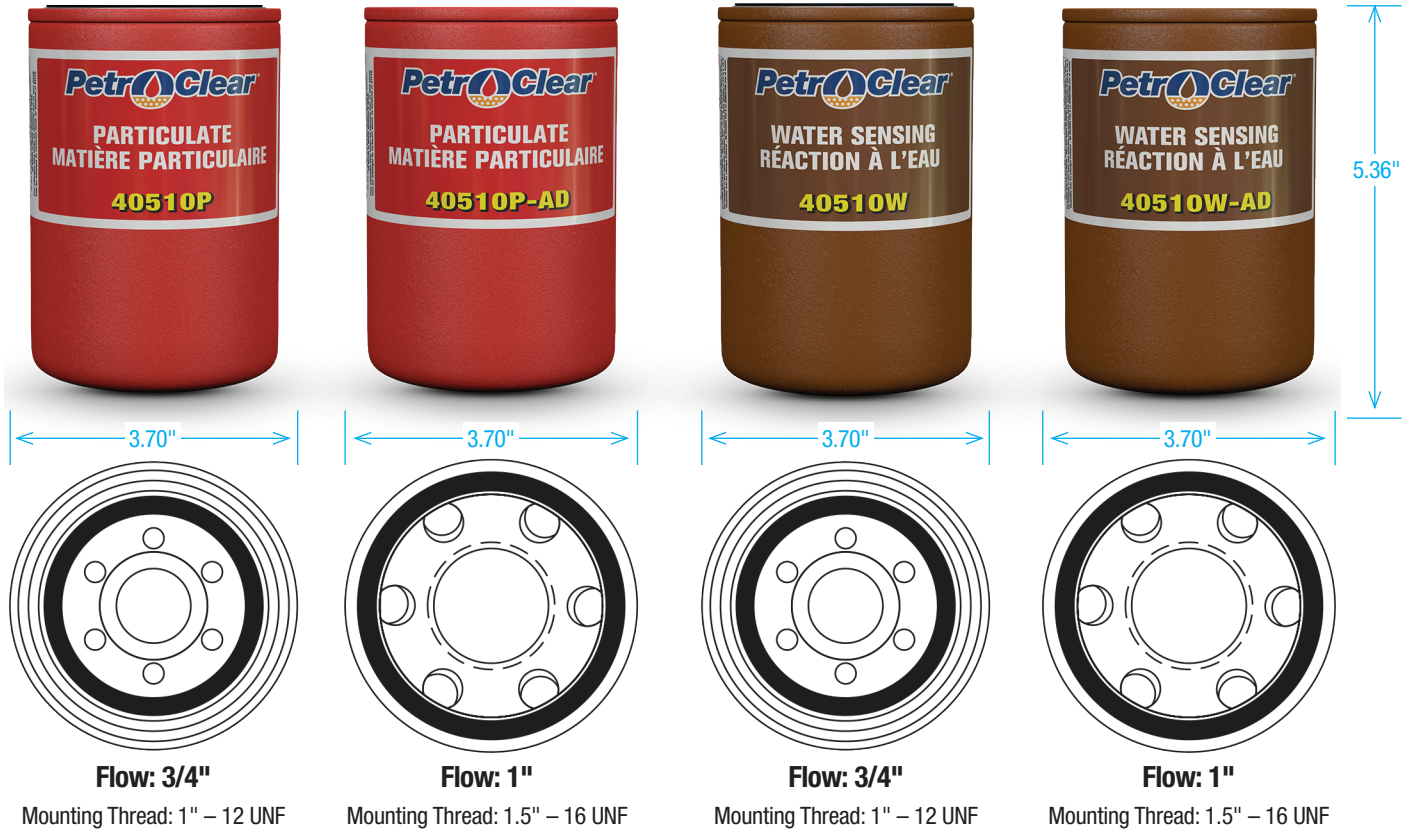

Filter Type	Spin-On
Media Type	Cellulose (Particulate Removing)
Micron Rating	2, 5, 10 and 30 Microns (nominal)
Shell Thickness	0.020
Flow Rate	25 gpm (94.6 lpm)
Gasket Material	Buna N
Collapse (Min.)	150 psid (10.3 bar)
Burst (Min.)	3/4" flow -250 psi (17.2 bar) 1" flow -500 psi (34.5 bar)
Max. Operating Temp.	250°F (139°C)
Min. Operating Temp.	-20°F (-28.9°C)
Other Features	UL Recognized

Not for use with aviation fuel.

Filter Type	Spin-On
Media Type	Cellulose with Super Absorbent Media (Water Sensing & Particulate Removing)
Micron Rating	10 and 30 Microns (nominal)
Shell Thickness	0.020
Flow Rate	25 gpm (94.6 lpm)
Gasket Material	Buna N
Collapse (Min.)	150 psid (10.3 bar)
Burst (Min.)	3/4" flow -250 psi (17.2 bar) 1" flow -500 psi (34.5 bar)
Max. Operating Temp.	250°F (139°C)
Min. Operating Temp.	-20°F (-28.9°C)
Other Features	UL Recognized

Not for use with aviation fuel.

NOTE: If you experience frequent filter changes, it is recommended that you have fuel samples analyzed to determine the source of contamination, such as water, dirt, rust, bacteria, phase separation, etc.



Particulate Removing Only

Spin-on filters designed for aftermarket cost efficient particulate filtration of fuels at high volume fueling locations such as truck stops, card lock sites, and industrial and commercial applications.

Water Sensing & Particulate Removing

Spin-on filters designed for aftermarket, cost efficient particulate filtration of fuels at high volume fueling locations such as truck stops, card lock sites, and industrial and commercial applications.



Flow: 1"
 Mounting Thread: 1.5" – 16 UNF
 Media Type: Cellulose

Cross Reference

CIM-TEK	PetroClear	CIM-TEK	PetroClear
70806 / 300-02	40502P	70075 / 450HS-10	40910W-AD
70808 / 400-02	40502P-AD	70076 / 450HS-30	40930W-AD
70122 / 300MB-10	40510A	70063 / 800HS-10	51110W
70120 / 400MB-10	40510A-AD	70068 / 800HS-30	51130W
70122 / 300MB-10	40510D	70019 / 800-10	51110P
70120 / 400MB-10	40510D-AD	70020 / 800-30	51130P
70059 / 300HS-10	40510W	30002 / E10	PCP-E10
70064 / 300HS-30	40530W	30004 / E30	PCP-E30
70010 / 300-10	40510P	30033 / EHS 10	PCW-E10
70012 / 300-30	40530P	30036 / EHS 30	PCW-E30
70060 / 400HS-10	40510W-AD	30001 / 500B-30	L3561F
70065 / 400HS-30	40530W-AD	30008 / E-1300-10	61810EP
70015 / 400-10	40510P-AD	30009 / E-1300-30	61830EP
70016 / 400-30	40530P-AD	30034 / E-1300HS-10	61810EW
70002 / 200E-10	40810P-DV	30037 / E-1300HS-30	61830EW
70046 / 200E-30	40830P-DV	50003 / 200H-3/4	75N1-12
70004 / 200AE-10	40810PA-DV	50181	75N1-12A
70045 / 200AE-30	40830PA-DV	50002 / 200H-1	1.0N1-12
70003 / 250E-10	40910P	50004 / 200AH	1.0N1-3/8-12
70094 / 260-10	40910P	50109	1.0N1.5-16
70061 / 260AHS-10	40910WA	50163	1.5N1.5-16
70066 / 260AHS-30	40930WA	50011	D2.0N1.5-16
70005 / 250AE-10	40910PA	50032	1.0N1 5-16AD
70089 / 250AE-30	40930PA	60001 / Pre-Vent	TV-2
70034 / 450-10	40910P-AD	60003 / Pre-Vent Cap	TV-RC-2
70027 / 450-30	40930P-AD	50001 / 200C	TC 1-12

Adapters

See the Adapter Reference section of this filtration handbook for more information on Adapter specifications and availability.

Flow: 1"
 Mounting Thread: 1.5" – 16 UNF
 Media Type: Cellulose with Super Absorbent Media

Filter Type	Spin-On	Spin-On
Micron Rating	03, 10 and 30 microns (nominal)	10 and 30 microns (nominal)
Shell Thickness	0.020	0.020
Flow Rate	40 gpm (151Lpm)	40 gpm (151Lpm)
Gasket Material	Buna N	Buna N
Collapse (Min.)	150 psid (10.3 bar)	150 psid (10.3 bar)
Burst (Min.)	250 psi (17.2 bar)	250 psi (17.2 bar)
Max. Operating Temp.	250°F (139°C)	250°F (139°C)
Other Features	UL Recognized	UL Recognized

Not for use with aviation fuel.

Fuel Dispenser Filters for Gilbarco®, Wayne® and other Popular Brands

PetroClear® state-of-the-art filters are available in a number of micron ratings to keep fuel clean and flowing easily.

Water Sensing and Particulate Removing

Our W Series (Brown) spin-on filters are designed to remove particulate and sense water in gasoline, diesel, Biodiesel, ULSD (Ultra Low Sulfur Diesel), Kerosene and fuel oils.

In the event that water is present in your site's fuel, these filters will noticeably slow the flow of your dispenser, prevent the dispensing of contaminated fuel, and allow site managers to address this issue.

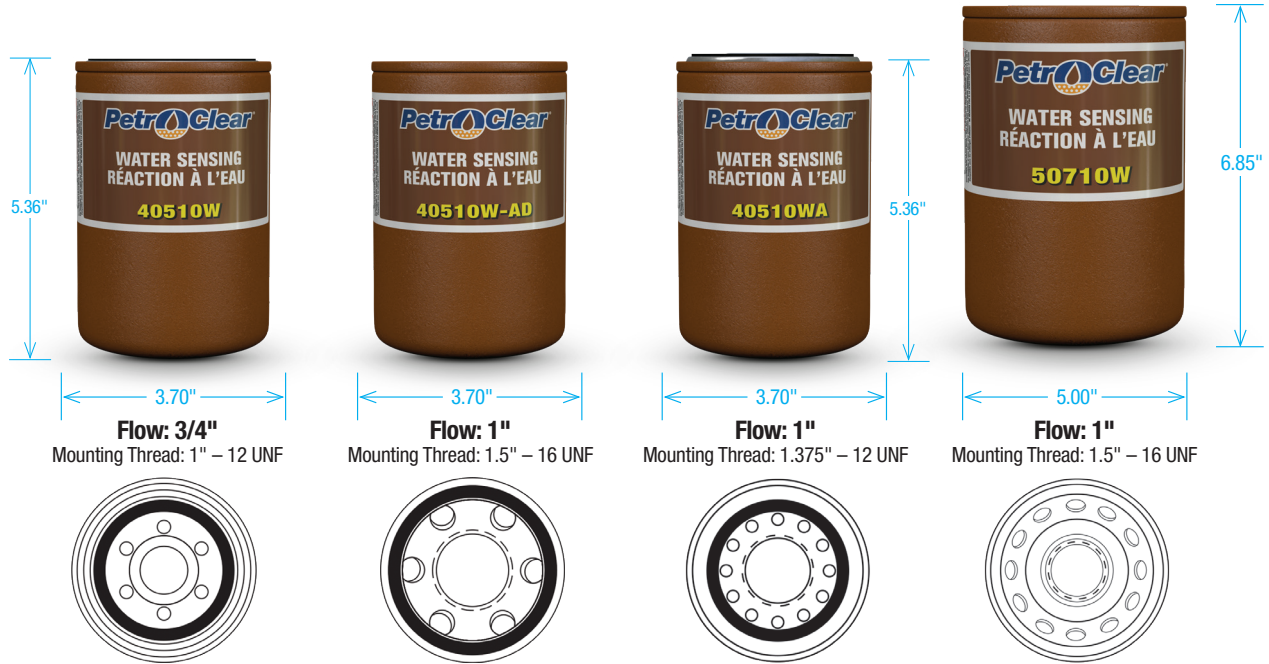

Filter Name	40510W	40510W-AD	40510WA*	50710W
Filter Type	Spin-On	Spin-On	Spin-On	Spin-On
Media Type	Cellulose with Super Absorbent Media	Cellulose with Super Absorbent Media	Cellulose with Super Absorbent Media	Cellulose with Super Absorbent Media
Micron Rating	10 and 30 Microns (nominal)	10 and 30 Microns (nominal)	10 and 30 Microns (nominal)	10 Microns (nominal)
Shell Thickness	0.020	0.020	0.020	0.020
Flow Rate	25 gpm (94.6 lpm)	25 gpm (94.6 lpm)	25 gpm (94.6 lpm)	40 gpm (151Lpm)
Gasket Material	Buna N	Buna N	Buna N	Buna N
Collapse (Min.)	150 psid (10.3 bar)	150 psid (10.3 bar)	150 psid (10.3 bar)	150 psid (10.3 bar)
Burst (Min.)	250 psi (17.2 bar)	500 psi (34.5 bar)	250 psi (17.2 bar)	200 psi (13.5 bar)
Max. Operating Temp.	250°F (139°C)	250°F (139°C)	250°F (139°C)	250°F (139°C)
Min. Operating Temp.	-20°F (-28.9°C)	-20°F (-28.9°C)	-20°F (-28.9°C)	-20°F (-28.9°C)
Other Features	UL Recognized	UL Recognized	Epoxy Coated Shell	

*For Agricultural Use Only

Not for use with aviation fuel.

NOTE: If you experience frequent filter changes, it is recommended that you have fuel samples analyzed to determine the source of contamination, such as water, dirt, rust, bacteria, phase separation, etc.



Water Sensing & Particulate Removing

These W (Brown) series spin-on filters are designed for aftermarket, cost efficient particulate filtration of fuels at high volume fueling locations such as truck stops, card lock sites, and industrial and commercial applications.

With water-sensing capabilities, they will detect the presence of free and emulsified water in your fuel, helping prevent engine damaging water from being dispensed into vehicle tanks.

40910W also available in both high-flow (AD) and agricultural models.



Flow: 3/4"

Mounting Thread: 1" – 12 UNF
Media Type: Cellulose with Super Absorbent Media

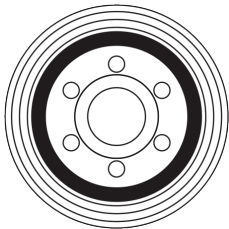

Flow: 1"

Mounting Thread: 1.5" – 16 UNF
Media Type: Cellulose with Super Absorbent Media

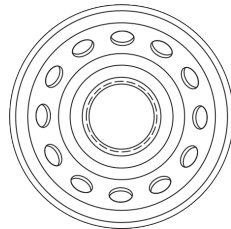

Filter Type	Spin-On
Micron Rating	10 and 30 microns (nominal)
Shell Thickness	0.020
Flow Rate	40910W: 25 gpm (94.6 Lpm) 51110W: 40 gpm (151Lpm)
Gasket Material	Buna N
Collapse (Min.)	150 psid (10.3 bar)
Burst (Min.)	40910W: 250 psi (17.2 bar) 51110W: 250 psi (17.2 bar)
Max. Operating Temp.	250°F (139°C)
Other Features	UL Recognized

Cross Reference

CIM-TEK	PetroClear	CIM-TEK	PetroClear
70806 / 300-02	40502P	70075 / 450HS-10	40910W-AD
70808 / 400-02	40502P-AD	70076 / 450HS-30	40930W-AD
70122 / 300MB-10	40510A	70063 / 800HS-10	51110W
70120 / 400MB-10	40510A-AD	70068 / 800HS-30	51130W
70122 / 300MB-10	40510D	70019 / 800-10	51110P
70120 / 400MB-10	40510D-AD	70020 / 800-30	51130P
70059 / 300HS-10	40510W	30002 / E10	PCP-E10
70064 / 300HS-30	40530W	30004 / E30	PCP-E30
70010 / 300-10	40510P	30033 / EHS 10	PCW-E10
70012 / 300-30	40530P	30036 / EHS 30	PCW-E30
70060 / 400HS-10	40510W-AD	30001 / 500B-30	L3561F
70065 / 400HS-30	40530W-AD	30008 / E-1300-10	61810EP
70015 / 400-10	40510P-AD	30009 / E-1300-30	61830EP
70016 / 400-30	40530P-AD	30034 / E-1300HS-10	61810EW
70002 / 200E-10	40810P-DV	30037 / E-1300HS-30	61830EW
70046 / 200E-30	40830P-DV	50003 / 200H-3/4	75N1-12
70004 / 200AE-10	40810PA-DV	50181	75N1-12A
70045 / 200AE-30	40830PA-DV	50002 / 200H-1	1.0N1-12
70003 / 250E-10	40910P	50004 / 200AH	1.0N1-3/8-12
70094 / 260-10	40910P	50109	1.0N1.5-16
70061 / 260AHS-10	40910WA	50163	1.5N1.5-16
70066 / 260AHS-30	40930WA	50011	D2.0N1.5-16
70005 / 250AE-10	40910PA	50032	1.0N1 5-16AD
70089 / 250AE-30	40930PA	60001 / Pre-Vent	TV-2
70034 / 450-10	40910P-AD	60003 / Pre-Vent Cap	TV-RC-2
70027 / 450-30	40930P-AD	50001 / 200C	TC 1-12

Adapters

See the Adapter Reference section of this filtration handbook for more information on Adapter specifications and availability.

Not for use with aviation fuel.



200 South Fourth Street | Albion, Illinois 62806-1313
Toll Free: 800-851-5990 | Fax: 800-545-1508
Outside U.S.: 618-445-6011 | Fax Outside U.S. & Canada: 618-445-4040

PetroClear.com



Fuel Dispenser Filters for Gilbarco®, Wayne® and other Popular Brands

PetroClear® state-of-the-art filters are available in a number of micron ratings to keep fuel clean and flowing easily.

Phase Separation Detection “Alert” & Particulate Removing

Spin-on filters designed to remove particulate from Ethanol blended fuels and protect against Phase Separation.

Phase Separation Detection & Water Sensing & Particulate Removing

Spin-on filters designed to remove particulate and to sense both free and emulsified water from neat gasoline or Ethanol blended gasoline and protect against Phase Separation.

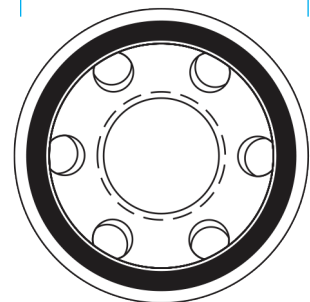
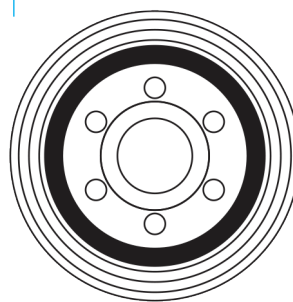
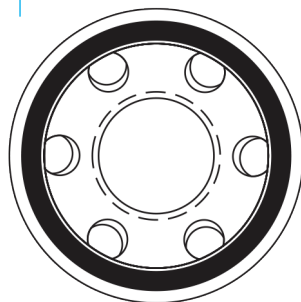
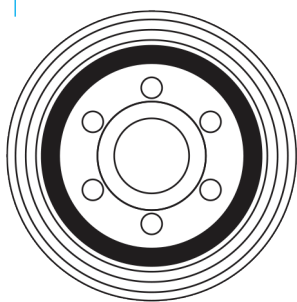

Flow: 3/4"

Flow: 1"

Flow: 3/4"

Flow: 1"

Mounting Thread: 1" – 12 UNF

Mounting Thread: 1.5" – 16 UNF

Mounting Thread: 1" – 12 UNF

Mounting Thread: 1.5" – 16 UNF

Filter Type	Spin-On
Media Type	Cellulose with Chemical Core (Particulate Removing & Detects Phase Separation)
Micron Rating	10 or 30 Microns (nominal)
Shell Thickness	0.020
Flow Rate	25 gpm (94.6 lpm)
Gasket Material	Buna N
Collapse (Min.)	150 psid (10.3 bar)
Burst (Min.)	3/4" flow -250 psi (17.2 bar) 1" flow - 500 (34.5 bar)
Max. Operating Temp.	250°F (139°C)
Min. Operating Temp.	-20°F (-28.9°C)
Other Features	UL Recognized

Filter Type	Spin-On
Media Type	Cellulose with Super Absorbent Media and Chemical Core
Micron Rating	10 or 30 Microns (nominal)
Shell Thickness	0.020
Flow Rate	25 gpm (94.6 lpm)
Gasket Material	Buna N
Collapse (Min.)	150 psid (10.3 bar)
Burst (Min.)	3/4" flow -250 psi (17.2 bar) 1" flow - 500 (34.5 bar)
Max. Operating Temp.	250°F (139°C)
Min. Operating Temp.	-20°F (-28.9°C)
Other Features	UL Recognized

Not for use with aviation fuel.

Not for use with aviation fuel.

NOTE: If you experience frequent filter changes, it is recommended that you have fuel samples analyzed to determine the source of contamination, such as water, dirt, rust, bacteria, phase separation, etc.



Phase Separation Detection “Alert” & Particulate Removing

Spin-on filters designed to remove particulate from Ethanol blended fuels and protect against Phase Separation.

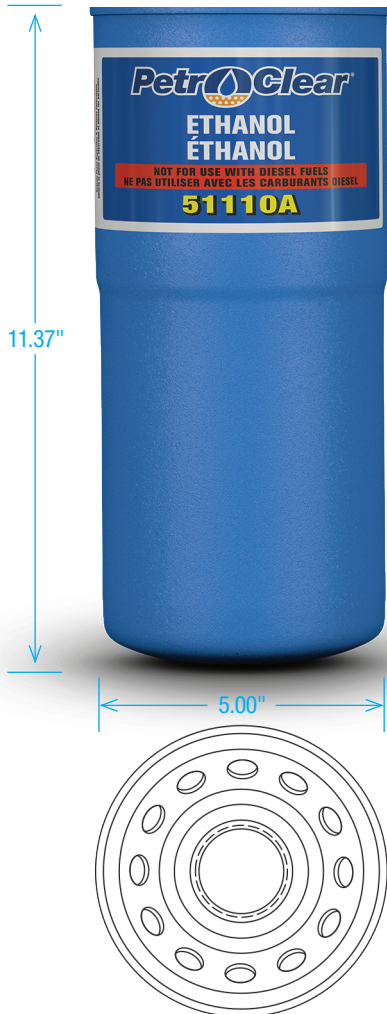

Flow: 1"

Mounting Thread: 1.5" – 16 UNF

Filter Type	Spin-On
Media Type	Cellulose with Chemical Core
Micron Rating	10 Microns (nominal)
Shell Thickness	0.020
Flow Rate	40 gpm (151Lpm)
Gasket Material	Buna N
Collapse (Min.)	150 psid (10.3 bar)
Burst (Min.)	250 psi (17.2 bar)
Other Features	UL Recognized

Not for use with aviation fuel.

Cross Reference

CIM-TEK	PetroClear	CIM-TEK	PetroClear
70806 / 300-02	40502P	70075 / 450HS-10	40910W-AD
70808 / 400-02	40502P-AD	70076 / 450HS-30	40930W-AD
70122 / 300MB-10	40510A	70063 / 800HS-10	51110W
70120 / 400MB-10	40510A-AD	70068 / 800HS-30	51130W
70122 / 300MB-10	40510D	70019 / 800-10	51110P
70120 / 400MB-10	40510D-AD	70020 / 800-30	51130P
70059 / 300HS-10	40510W	30002 / E10	PCP-E10
70064 / 300HS-30	40530W	30004 / E30	PCP-E30
70010 / 300-10	40510P	30033 / EHS 10	PCW-E10
70012 / 300-30	40530P	30036 / EHS 30	PCW-E30
70060 / 400HS-10	40510W-AD	30001 / 500B-30	L3561F
70065 / 400HS-30	40530W-AD	30008 / E-1300-10	61810EP
70015 / 400-10	40510P-AD	30009 / E-1300-30	61830EP
70016 / 400-30	40530P-AD	30034 / E-1300HS-10	61810EW
70002 / 200E-10	40810P-DV	30037 / E-1300HS-30	61830EW
70046 / 200E-30	40830P-DV	50003 / 200H-3/4	75N1-12
70004 / 200AE-10	40810PA-DV	50181	75N1-12A
70045 / 200AE-30	40830PA-DV	50002 / 200H-1	1.0N1-12
70003 / 250E-10	40910P	50004 / 200AH	1.0N1-3/8-12
70094 / 260-10	40910P	50109	1.0N1.5-16
70061 / 260AHS-10	40910WA	50163	1.5N1.5-16
70066 / 260AHS-30	40930WA	50011	D2.0N1.5-16
70005 / 250AE-10	40910PA	50032	1.0N1 5-16AD
70089 / 250AE-30	40930PA	60001 / Pre-Vent	TV-2
70034 / 450-10	40910P-AD	60003 / Pre-Vent Cap	TV-RC-2
70027 / 450-30	40930P-AD	50001 / 200C	TC 1-12

Adapters

See the Adapter Reference section of this filtration handbook for more information on Adapter specifications and availability.



200 South Fourth Street | Albion, Illinois 62806-1313

Toll Free: 800-851-5990 | Fax: 800-545-1508

Outside U.S.: 618-445-6011 | Fax Outside U.S. & Canada: 618-445-4040

PetroClear.com



Fuel Dispenser Filters for Gilbarco®, Wayne® and other Popular Brands

PetroClear® state-of-the-art filters are available in a number of micron ratings to keep fuel clean and flowing easily.

Particulate Removing Only

Our P Series (Red) spin-on filters are designed to remove particulate from neat gasoline, Ethanol blended gasoline, diesel, Biodiesel, ULSD (Ultra Low Sulfur Diesel), kerosene, fuel oils and Ethanol fuels.

Offered with the widest range of available micron ratings, from 2 to 30 (nominal), you can be assured that there will be a filter in this series that meets the particulate removing needs of your site.

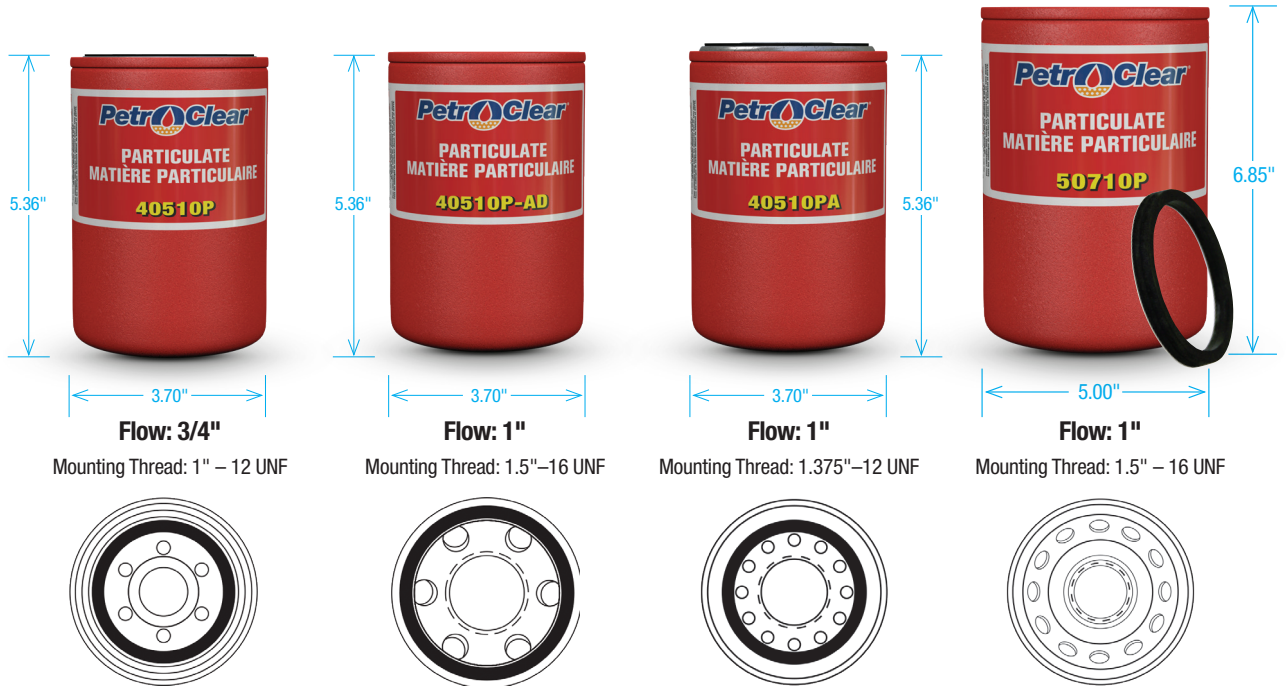

Filter Name	40510P	40510P-AD	40510PA*	50710P
Filter Type	Spin-On	Spin-On	Spin-On	Spin-On
Media Type	Cellulose (Particulate Removing)	Cellulose (Particulate Removing)	Cellulose (Particulate Removing)	Cellulose (Particulate Removing)
Micron Rating	2, 5, 10 and 30 Microns (nominal)	2, 5, 10 and 30 Microns (nominal)	10 and 30 Microns (nominal)	10 Microns (nominal)
Shell Thickness	0.020	0.020	0.020	0.020
Flow Rate	25 gpm (94.6 lpm)	25 gpm (94.6 lpm)	25 gpm (94.6 lpm)	40 gpm (151 lpm)
Gasket Material	Buna N	Buna N	Buna N	Buna N
Collapse (Min.)	150 psid (10.3 bar)	150 psid (10.3 bar)	150 psid (10.3 bar)	150 psid (10.3 bar)
Burst (Min.)	3/4" flow -250 psi (17.2 bar)	1" flow -500 psi (34.5 bar)	1" flow -250 psi (17.2 bar)	1" flow -200 psi (13.5 bar)
Max. Operating Temp.	250°F (139°C)	250°F (139°C)	250°F (139°C)	250°F (139°C)
Min. Operating Temp.	-20°F (-28.9°C)	-20°F (-28.9°C)	-20°F (-28.9°C)	-20°F (-28.9°C)
Other Features	UL Recognized	UL Recognized	Epoxy Coated Shell	

*For Agricultural Use Only

Not for use with aviation fuel.

NOTE: If you experience frequent filter changes, it is recommended that you have fuel samples analyzed to determine the source of contamination, such as water, dirt, rust, bacteria, phase separation, etc.





Particulate Removing Only

These spin-on filters are designed for the aftermarket, cost efficient particulate filtration of fuels at high volume fueling locations such as truck stops, card lock sites, and industrial and commercial applications.



Flow: 3/4"
Mounting Thread: 1" – 12 UNF
Media Type: Cellulose



Flow: 3/4"
Mounting Thread: 1" – 12 UNF
Media Type: Silicon Treated Cellulose
(Not for Commercial Dispenser Use)



Flow: 1"
Mounting Thread: 1.5" – 16 UNF
Media Type: Cellulose

Filter Type	40910P	40810P-DV	51110P
Filter Type	Spin-On	Spin-On	Spin-On
Micron Rating	10 and 30 microns (nominal)	10 and 30 microns (nominal)	03, 10 and 30 microns (nominal)
Shell Thickness	0.020	0.020	0.020
Flow Rate	25 gpm (94.6 lpm)	25 gpm (94.6 lpm)	40 gpm (151Lpm)
Gasket Material	Buna N	Buna N	Buna N
Collapse (Min.)	150 psid (10.3 bar)	150 psid (10.3 bar)	150 psid (10.3 bar)
Burst (Min.)	250 psi (17.2 bar)	250 psi (17.2 bar)	250 psi (17.2 bar)
Max. Operating Temp.	250°F (139°C)	250°F (139°C)	250°F (139°C)

Not for use with aviation fuel.

Cross Reference

CIM-TEK	PetroClear	CIM-TEK	PetroClear
70806 / 300-02	40502P	70075 / 450HS-10	40910W-AD
70808 / 400-02	40502P-AD	70076 / 450HS-30	40930W-AD
70122 / 300MB-10	40510A	70063 / 800HS-10	51110W
70120 / 400MB-10	40510A-AD	70068 / 800HS-30	51130W
70122 / 300MB-10	40510D	70019 / 800-10	51110P
70120 / 400MB-10	40510D-AD	70020 / 800-30	51130P
70059 / 300HS-10	40510W	30002 / E10	PCP-E10
70064 / 300HS-30	40530W	30004 / E30	PCP-E30
70010 / 300-10	40510P	30033 / EHS 10	PCW-E10
70012 / 300-30	40530P	30036 / EHS 30	PCW-E30
70060 / 400HS-10	40510W-AD	30001 / 500B-30	L3561F
70065 / 400HS-30	40530W-AD	30008 / E-1300-10	61810EP
70015 / 400-10	40510P-AD	30009 / E-1300-30	61830EP
70016 / 400-30	40530P-AD	30034 / E-1300HS-10	61810EW
70002 / 200E-10	40810P-DV	30037 / E-1300HS-30	61830EW
70046 / 200E-30	40830P-DV	50003 / 200H-3/4	75N1-12
70004 / 200AE-10	40810PA-DV	50181	75N1-12A
70045 / 200AE-30	40830PA-DV	50002 / 200H-1	1.0N1-12
70003 / 250E-10	40910P	50004 / 200AH	1.0N1-3/8-12
70094 / 260-10	40910P	50109	1.0N1.5-16
70061 / 260AHS-10	40910WA	50163	1.5N1.5-16
70066 / 260AHS-30	40930WA	50011	02.0N1.5-16
70005 / 250AE-10	40910PA	50032	1.0N1 5-16AD
70089 / 250AE-30	40930PA	60001 / Pre-Vent	TV-2
70034 / 450-10	40910P-AD	60003 / Pre-Vent Cap	TV-RC-2
70027 / 450-30	40930P-AD	50001 / 200C	TC 1-12

Adapters

See the Adapter Reference section of this filtration handbook for more information on Adapter specifications and availability.



200 South Fourth Street | Albion, Illinois 62806-1313

Toll Free: 800-851-5990 | Fax: 800-545-1508

Outside U.S.: 618-445-6011 | Fax Outside U.S. & Canada: 618-445-4040

PetroClear.com



Fuel Dispenser Filters for Gilbarco®, Wayne® and other Popular Brands

PetroClear® state-of-the-art filters are available in a number of micron ratings to keep fuel clean and flowing easily.

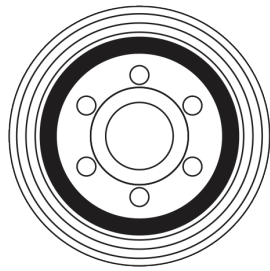

Flow 3/4"

Mounting Thread: 1" – 12 UNF

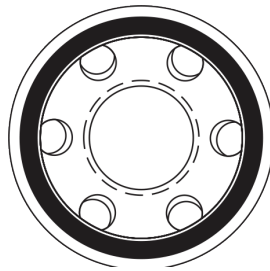

Flow: 1"

Mounting Thread: 1.5" – 16 UNF

Filter Type	Spin-On
Media Type	Cellulose with Super Absorbent Media and Chemical Core (Particulate Removing)
Micron Rating	10 or 30 Microns (nominal)
Shell Thickness	0.020
Flow Rate	25 gpm (94.6 lpm)
Gasket Material	Buna N
Collapse (Min.)	150 psid (10.3 bar)
Burst (Min.)	3/4" flow -250 psi (17.2 bar) (40510D) 1" flow-500 psi (34.5 bar) (40510D-AD)
Max. Operating Temp.	250°F (139°C)
Min. Operating Temp.	-20°F (-28.9°C)
Other Features	UL Recognized

Not for use with aviation fuel.

D Series –“Dual Purpose”

Patented technology makes our “Dual Purpose” filters the only filters on the market that protect during the transition from non-ethanol fuels to ethanol blends, or vice-versa, without changing filters. These filters are designed to remove particulate, offer water sensing capabilities in non-ethanol blends, and also detect phase separation in ethanol blended fuels.

Cross Reference

CIM-TEK	PetroClear	CIM-TEK	PetroClear
70806 / 300-02.....	40502P	70075 / 450HS-10.....	40910W-AD
70808 / 400-02.....	40502P-AD	70076 / 450HS-30.....	40930W-AD
70122 / 300MB-10.....	40510A	70063 / 800HS-10.....	51110W
70120 / 400MB-10.....	40510A-AD	70068 / 800HS-30.....	51130W
70122 / 300MB-10.....	40510D	70019 / 800-10.....	51110P
70120 / 400MB-10.....	40510D-AD	70020 / 800-30.....	51130P
70059 / 300HS-10.....	40510W	30002 / E10.....	PCP-E10
70064 / 300HS-30.....	40530W	30004 / E30.....	PCP-E30
70010 / 300-10.....	40510P	30033 / EHS 10.....	PCW-E10
70012 / 300-30.....	40530P	30036 / EHS 30.....	PCW-E30
70060 / 400HS-10.....	40510W-AD	30001 / 500B-30.....	L3561F
70065 / 400HS-30.....	40530W-AD	30008 / E-1300-10.....	61810EP
70015 / 400-10.....	40510P-AD	30009 / E-1300-30.....	61830EP
70016 / 400-30.....	40530P-AD	30034 / E-1300HS-10.....	61810EW
70002 / 200E-10.....	40810P-DV	30037 / E-1300HS-30.....	61830EW
70046 / 200E-30.....	40830P-DV	50003 / 200H-3/4.....	.75N1-12
70004 / 200AE-10.....	40810PA-DV	50181.....	.75N1-12A
70045 / 200AE-30.....	40830PA-DV	50002 / 200H-1.....	1.0N1-12
70003 / 250E-10.....	40910P	50004 / 200AH.....	1.0N1-3/8-12
70094 / 260-10.....	40910P	50109.....	1.0N1.5-16
70061 / 260AHS-10.....	40910WA	50163.....	1.5N1.5-16
70066 / 260AHS-30.....	40930WA	50011.....	D2.0N1.5-16
70005 / 250AE-10.....	40910PA	50032.....	1.0N1 5-16AD
70089 / 250AE-30.....	40930PA	60001 / Pre-Vent.....	TV-2
70034 / 450-10.....	40910P-AD	60003 / Pre-Vent Cap.....	TV-RC-2
70027 / 450-30.....	40930P-AD	50001 / 200C.....	TC 1-12

Adapters

See the Adapter Reference section of this filtration handbook for more information on Adapter specifications and availability.



200 South Fourth Street | Albion, Illinois 62806-1313

Toll Free: 800-851-5990 | Fax: 800-545-1508

Outside U.S.: 618-445-6011 | Fax Outside U.S. & Canada: 618-445-4040

PetroClear.com

NOTE: If you experience frequent filter changes, it is recommended that you have fuel samples analyzed to determine the source of contamination, such as water, dirt, rust, bacteria, phase separation, etc.



Fuel Dispenser Filters for Gilbarco®, Wayne® and other Popular Brands

PetroClear® state-of-the-art filters are available in a number of micron ratings to keep fuel clean and flowing easily.

405 Series “Alert”

Our “Alert” series spin-on filters are designed to effectively remove particulate from Ethanol blended fuels. In addition to these particulate removing capabilities, they also offer stop flow capabilities in the event of fuel phase separation.

Should phase separated fuel begin to pump from a dispenser with an “alert” series filter present, the flow of the dispenser will noticeably slow, preventing contaminated fuel from being pumped into the consumer’s vehicle.

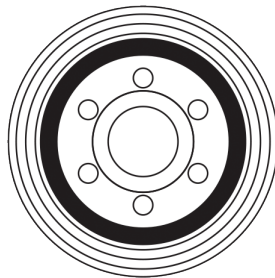

Flow: 3/4" Mounting Thread: 1" – 12 UNF

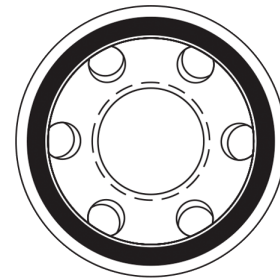

Flow: 1" Mounting Thread: 1.50" – 16 UNF

Filter Type	Spin-On
Media Type	Cellulose with Chemical Core
Micron Rating	10 and 30 Microns (nominal)
Shell Thickness	0.020
Flow Rate	25 gpm (94.6 lpm)
Gasket Material	Buna N
Collapse (Min.)	150 psid (10.3 bar)
Burst (Min.)	250 psi (17.2 bar)
Max. Operating Temp.	250°F (139°C)
Min. Operating Temp.	-20°F (-28.9°C)
Other Features	UL Recognized

Filter Type	Spin-On
Media Type	Cellulose with Chemical Core
Micron Rating	10 and 30 Microns (nominal)
Shell Thickness	0.020
Flow Rate	25 gpm (94.6 lpm)
Gasket Material	Buna N
Collapse (Min.)	150 psid (10.3 bar)
Burst (Min.)	500 psi (34.5 bar)
Max. Operating Temp.	250°F (139°C)
Min. Operating Temp.	-20°F (-28.9°C)
Other Features	UL Recognized

Not for use with aviation fuel.

Not for use with aviation fuel.

NOTE: If you experience frequent filter changes, it is recommended that you have fuel samples analyzed to determine the source of contamination, such as water, dirt, rust, bacteria, phase separation, etc.

Phase Separation Detection “Alert” & Particulate Removing

These spin-on filters are designed for the aftermarket, cost efficient particulate filtration of fuels at high volume fueling locations such as truck stops, card lock sites, and industrial and commercial applications. With phase separation sensing capabilities, it is engineered to noticeably slow dispenser flow in the presence of phase separated fuel, allowing site managers to address this issue.



Cross Reference

CIM-TEK	PetroClear	CIM-TEK	PetroClear
70806 / 300-02	40502P	70075 / 450HS-10	40910W-AD
70808 / 400-02	40502P-AD	70076 / 450HS-30	40930W-AD
70122 / 300MB-10	40510A	70063 / 800HS-10	51110W
70120 / 400MB-10	40510A-AD	70068 / 800HS-30	51130W
70122 / 300MB-10	40510D	70019 / 800-10	51110P
70120 / 400MB-10	40510D-AD	70020 / 800-30	51130P
70059 / 300HS-10	40510W	30002 / E10	PCP-E10
70064 / 300HS-30	40530W	30004 / E30	PCP-E30
70010 / 300-10	40510P	30033 / EHS 10	PCW-E10
70012 / 300-30	40530P	30036 / EHS 30	PCW-E30
70060 / 400HS-10	40510W-AD	30001 / 500B-30	L3561F
70065 / 400HS-30	40530W-AD	30008 / E-1300-10	61810EP
70015 / 400-10	40510P-AD	30009 / E-1300-30	61830EP
70016 / 400-30	40530P-AD	30034 / E-1300HS-10	61810EW
70002 / 200E-10	40810P-DV	30037 / E-1300HS-30	61830EW
70046 / 200E-30	40830P-DV	50003 / 200H-3/4	75N1-12
70004 / 200AE-10	40810PA-DV	50181	75N1-12A
70045 / 200AE-30	40830PA-DV	50002 / 200H-1	1.0N1-12
70003 / 250E-10	40910P	50004 / 200AH	1.0N1-3/8-12
70094 / 260-10	40910P	50109	1.0N1.5-16
70061 / 260AHS-10	40910WA	50163	1.5N1.5-16
70066 / 260AHS-30	40930WA	50011	D2.0N1.5-16
70005 / 250AE-10	40910PA	50032	1.0N1 5-16AD
70089 / 250AE-30	40930PA	60001 / Pre-Vent	TV-2
70034 / 450-10	40910P-AD	60003 / Pre-Vent Cap	TV-RC-2
70027 / 450-30	40930P-AD	50001 / 200C	TC 1-12

Adapters

See the Adapter Reference section of this filtration handbook for more information on Adapter specifications and availability.

Flow: 1"

Mounting Thread: 1.5" – 16 UNF

Filter Type	Spin-On
Media Type	Cellulose with Chemical Core
Micron Rating	10 Microns (nominal)
Shell Thickness	0.020
Flow Rate	40 gpm (151Lpm)
Gasket Material	Buna N
Collapse (Min.)	150 psid (10.3 bar)
Burst (Min.)	250 psi (17.2 bar)
Other Features	UL Recognized

Not for use with aviation fuel.



200 South Fourth Street | Albion, Illinois 62806-1313
 Toll Free: 800-851-5990 | Fax: 800-545-1508
 Outside U.S.: 618-445-6011 | Fax Outside U.S. & Canada: 618-445-4040

PetroClear.com



Filtros para surtidores de combustible para Gilbarco®, Wayne® y otras marcas populares

Los filtros PetroClear® de tecnología avanzada están disponibles en un número de tamaños en micrones para mantener el combustible limpio y con buena fluidez.

Sólo eliminación de partículas

Filtros giratorios diseñados para eliminar partículas de gasolina pura, gasolina con mezcla de etanol, diesel, biodiesel, ULSD (diesel con contenido de azufre ultra bajo), queroseno, combustibles de etanol y aceites combustibles.

Detección de agua y eliminación de partículas

Filtros giratorios diseñados para eliminar partículas y detectar agua libre y emulsificada proveniente de gasolina, diesel, biodiesel, ULSD (diesel con contenido de azufre ultra bajo), queroseno y aceites combustibles.

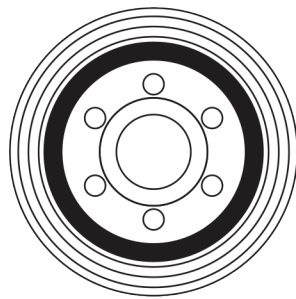

Flujo: 3/4"

Rosca de montaje: 1" – 12 UNF

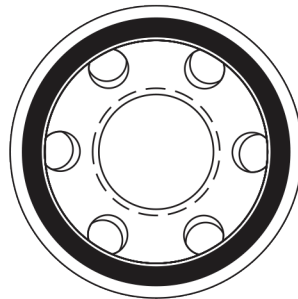

Flujo: 1"

Rosca de montaje: 1.5" – 16 UNF

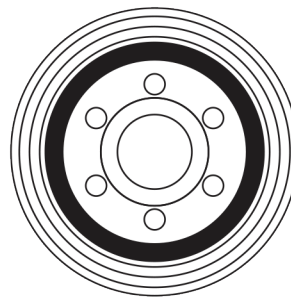

Flujo: 3/4"

Rosca de montaje: 1" – 12 UNF

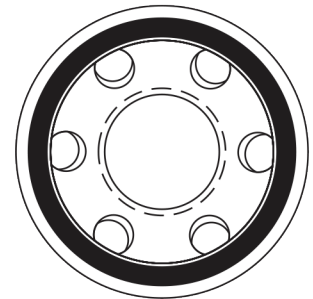

Flujo: 1"

Rosca de montaje: 1.5" – 16 UNF

Tipo de filtro	Giratorio
Tipo de medio	*Celulosa
Tamaño en micrones	2, 5, 10 y 30 micrones (nominal) (Nominal = 75% de eficiencia)
Espesor de la estructura	0.020
Material de la junta	Buna N
Presión de colapso (mínima)	150 psid (10.3 bar)
Presión de ruptura (mínima)	P-250 psi (17.2 bar) AD-500 psi (34.5 bar)
Temperatura operativa máxima	250°F (139°C)
Temperatura operativa mínima	-20°F (-28.9°C)
Otras características	reconocido por UL

Tipo de filtro	Giratorio
Tipo de medio	*Celulosa con medios super absorbentes
Tamaño en micrones	10 y 30 micrones (nominal) (Nominal = 75% de eficiencia)
Espesor de la estructura	0.020
Material de la junta	Buna N
Presión de colapso (mínima)	150 psid (10.3 bar)
Presión de ruptura (mínima)	W-250 psi (17.2 bar) AD-500 psi (34.5 bar)
Temperatura operativa máxima	250°F (139°C)
Temperatura operativa mínima	-20°F (-28.9°C)
Otras características	reconocido por UL

Los filtros PetroClear no deben utilizarse en aplicaciones de combustibles para aviación.

Los filtros PetroClear no deben utilizarse en aplicaciones de combustibles para aviación.

NOTA: Si experimenta frecuentes cambios de filtros, se recomienda que haga analizar las muestras de combustible para determinar la fuente de contaminación, tal como agua, suciedad, herrumbre, bacterias, separación de fases, etc.



Sólo eliminación de partículas

Filtros giratorios diseñados para la filtración de partículas de manera eficiente con respecto a costos en el mercado de posventa, en ubicaciones de abastecimiento de combustible de gran volumen tales como paradas de camiones, sitios de cerradura mediante tarjeta magnética y aplicaciones industriales y comerciales.

Detección de agua y eliminación de partículas

Filtros giratorios diseñados para la filtración de partículas de manera eficiente con respecto a costos en el mercado de posventa, en ubicaciones de abastecimiento de combustible de gran volumen tales como paradas de camiones, sitios de cerradura mediante tarjeta magnética y aplicaciones industriales y comerciales.

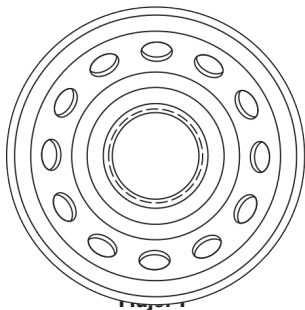

Rosca de montaje: 1.5" – 16 UNF
Tipo de medio: Celulosa

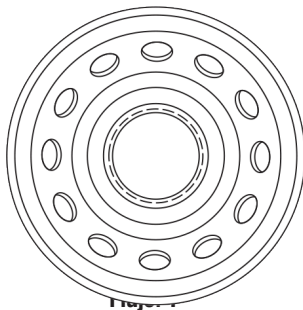

Rosca de montaje: 1.5" – 16 UNF
Tipo de medio: Celulosa con medios super absorbentes

Tipo de filtro	Giratorio
Tamaño en micrones	03, 10 y 30 micrones (nominal) (Nominal = 75% de eficiencia)
Espesor de la estructura	0.020
Material de la junta	Buna N
Presión de colapso (mínima)	150 psid (10.3 bar)
Presión de ruptura (mínima)	250 psi (17.2 bar)
Temperatura operativa máxima	250°F (139°C)
Otras características	UL reconocido

Los filtros PetroClear no deben utilizarse en aplicaciones de combustibles para aviación.

Referencia cruzada

*No es un cierre positivo

CIM-TEK	PetroClear	CIM-TEK	PetroClear
70806 / 300-02	40502P	70075 / 450HS-10	40910W-AD
70808 / 400-02	40502P-AD	70076 / 450HS-30	40930W-AD
70122 / 300MB-10	40510A	70063 / 800HS-10	51110W
70120 / 400MB-10	40510A-AD	70068 / 800HS-30	51130W
70122 / 300MB-10	40510D	70019 / 800-10	51110P
70120 / 400MB-10	40510D-AD	70020 / 800-30	51130P
70059 / 300HS-10	40510W	30002 / E10	PCP-E10
70064 / 300HS-30	40530W	30004 / E30	PCP-E30
70010 / 300-10	40510P	30033 / EHS 10	PCW-E10
70012 / 300-30	40530P	30036 / EHS 30	PCW-E30
70060 / 400HS-10	40510W-AD	30001 / 500B-30	L3561F
70065 / 400HS-30	40530W-AD	30008 / E-1300-10	61810EP
70015 / 400-10	40510P-AD	30009 / E-1300-30	61830EP
70016 / 400-30	40530P-AD	30034 / E-1300HS-10	61810EW
70002 / 200E-10	40810P-DV	30037 / E-1300HS-30	61830EW
70046 / 200E-30	40830P-DV	50003 / 200H-3/4	75N1-12
70004 / 200AE-10	40810PA-DV	50181	75N1-12A
70045 / 200AE-30	40830PA-DV	50002 / 200H-1	1.0N1-12
70003 / 250E-10	40910P	50004 / 200AH	1.0N1-3/8-12
70094 / 260-10	40910P	50109	1.0N1.5-16
70061 / 260AHS-10	40910WA	50163	1.5N1.5-16
70066 / 260AHS-30	40930WA	50011	D2.0N1.5-16
70005 / 250AE-10	40910PA	50032	1.0N1 5-16AD
70089 / 250AE-30	40930PA	60001 / Pre-Vent	TV-2
70034 / 450-10	40910P-AD	60003 / Pre-Vent Cap	TV-RC-2
70027 / 450-30	40930P-AD	50001 / 200C	TC 1-12

Adaptadores

Consulte la sección referencia de este manual de filtración para obtener más información sobre la disponibilidad y las especificaciones del adaptador.



200 South Fourth Street | Albion, Illinois 62806-1313
 Gratis: 800-851-5990 | Fax: 800-545-1508
 Fuera de EE. UU.: 618-445-6011 | Fax fuera de EE. UU.
 y Canadá: 618-445-4040 PetroClear.com





Replacing Filters is Now as Quick, Easy and Accurate as...

Pick A Color!



Phase Separation Detection & Water Sensing & Particulate Removing



Phase Separation Detection "Alert" & Particulate Removing



Water Sensing & Particulate Removing



Particulate Removing Only

NEW Large Print Labels



200 South Fourth Street | Albion, Illinois 62806-1313
Toll Free: 800-851-5990 | Fax: 800-545-1508
Outside U.S.: 618-445-6011
Fax Outside U.S. & Canada: 618-445-4040

PetroClear.com

Additional Print Materials



Dispenser Sticker



Product Trifold



Inside dispenser poster



Pocket Folder

NOTE: If you experience frequent filter changes, it is recommended that you have fuel samples analyzed to determine the source of contamination, such as water, dirt, rust, bacteria, phase separation, etc.

SPANISH SALES & MARKETING Materials

1-800-851-5990 • PetroClear.com

Guía de las Etiquetas de "TODO PARECE EN SU ETIQUETA."

Su Código de Parte le explique todo! Su Diámetro, Altura, Micras

Claves de Códigos

40530A-

Diámetro del Filtro: 3.65" sea como 4"

Altura del Filtro: 5.36" sea como 5"

Filtración en Micras: 3000

Función (ver Flujo)

Función:

- A** = (Anuncio) Detección de Separación de Fases con Filtración de Partículas
- D** = (Doble) Detección de Agua Y Separación de Fases
- P** = Partículas Filtración Solamente
- W** = Detección de Agua y Filtración de Partículas
- DW** = Winhula de Drenaje
- PA** = Partículas para Agrícola. (1-3/8 - 12 UNF Flujo de 1")
- WA** = Detección de Agua y Filtración de Partículas para Agrícola. (1-3/8 - 12 UNF Flujo de 1")

Referencia de Colores les Ayuda para Identificación Rápida de

ROJO Filtración de Partículas Solamente

CAFÉ Detección de Agua y Filtración de Partículas

AZUL Detección de Separación de Fases "Anuncio" Filtración de Partículas

Champion Laboratories, Inc.
200 South Fourth Street, Abion, IL 62806-1313
Teléfono: (618) 445-0211 • Fax: (618) 445-4040

www.PetroClear.com

1-800-851-5990 • PetroClear.com

Filtros para surtidores de combustible para Gilbarco®, Wayne® y otras marcas populares

Los filtros PetroClear® de tecnología avanzada están disponibles en un número de tamaños en micrones para mantener el combustible limpio y con buena fluidez.

"Alerta" de detección de separación de fases y eliminación de partículas
Filtros giratorios diseñados para eliminar partículas de combustibles con mezcla de etanol y proteger contra la separación de fases.

Detección de separación de fases, detección de agua y eliminación de partículas
Filtros giratorios diseñados para eliminar partículas y detectar agua libre y emulsionada proveniente de gasolina pura o gasolina con mezcla de etanol, y para proteger contra la separación de fases.

Flujo: 3/4" Rosca de montaje: 1" - 12 UNF

Flujo: 1" Rosca de montaje: 1.5" - 16 UNF

Tipo de filtro	Giratorio
Tipo de medio	*Celulosa con núcleo químico
Tamaño en micrones	10 o 30 micrones (nominal) (Nominal = 75% de eficiencia)
Espesor de la estructura	0.020
Material de la junta	Buna N
Presión de colapso (mínima)	150 psid (10.3 bar)
Presión de ruptura (mínima)	A -250 psid (17.2 bar) AD -500 psid (34.5 bar)
Temperatura operativa máxima	250°F (139°C)
Temperatura operativa mínima	-20°F (-28.9°C)
Otras características	reconocido por UL

Los filtros PetroClear no deben utilizarse en aplicaciones de combustibles para aviación.

1-800-851-5990 • PetroClear.com

Filtros para surtidores de combustible para Gilbarco®, Wayne® y otras marcas populares

Los filtros PetroClear® de tecnología avanzada están disponibles en un número de tamaños en micrones para mantener el combustible limpio y con buena fluidez.

Sólo eliminación de partículas
Filtros giratorios diseñados para eliminar partículas de gasolina pura, gasolina con mezcla de etanol, diesel, biodiesel, ULSD (diesel con contenido de azufre ultra bajo), queroseno, y aceites combustibles.

Detección de agua y eliminación de partículas
Filtros giratorios diseñados para eliminar partículas y detectar agua libre y emulsionada proveniente de gasolina, diesel, biodiesel, ULSD (diesel con contenido de azufre ultra bajo), queroseno y aceites combustibles.

Flujo: 1" Rosca de montaje: 1.5" - 16 UNF

Flujo: 3/4" Rosca de montaje: 1" - 12 UNF

Flujo: 1" Rosca de montaje: 1.5" - 16 UNF

Tipo de filtro	Giratorio
Tipo de medio	*Celulosa con medios super absorbentes
Tamaño en micrones	10 y 30 micrones (nominal) (Nominal = 75% de eficiencia)
Espesor de la estructura	0.020
Material de la junta	Buna N
Presión de colapso (mínima)	150 psid (10.3 bar)
Presión de ruptura (mínima)	W-250 psid (17.2 bar) AD-500 psid (34.5 bar)
Temperatura operativa máxima	250°F (139°C)
Temperatura operativa mínima	-20°F (-28.9°C)
Otras características	reconocido por UL

Los filtros PetroClear no deben utilizarse en aplicaciones de combustibles para aviación.

recomendamos que haga analizar las muestras de combustible para detectar agua, suciedad, herrumbre, bacterias, separación de fases, etc.

NOTE: If you experience frequent filter changes, it is recommended that you have fuel samples analyzed to determine the source of contamination, such as water, dirt, rust, bacteria, phase separation, etc.

Guía de las Etiquetas de los Filtros

“TODO PARECE EN SU ETIQUETA.”

Su Codigo de Parte le explique todo! Su Diámetro, Altura, Micras, Tipo de Filtración y mas

Claves de Códigos

40530A-AD

Diámetro del Filtro
3.69" sea como 4"

Altura del Filtro
5.36" sea como 5"

Filtración en Micras
30=30

Función
(Ver Abajo)

AD = Alta Diámetro
Flujo de 1" para Dispensarios de 1" de Alta Flujo

Función:

A	= (Anuncio) Detección de Separación de Fases con Filtración de Partículas
D	= (Doble) Detección de Agua Y Separación de Fases
P	= Partículas Filtración Solamente
W	= Detección de Agua y Filtración de Partículas
DV	= Válvula de Drenaje
PA	= Partículas para Agrícola, (1-3/8 - 12 UNF Flujo de 1")
WA	= Detección de Agua y Filtración de Partículas para Agrícola, (1-3/8 - 12 UNF Flujo de 1")

Información del Aplicación

(nulo)* = Roscas 1-12 UNF (Flujo de 3/4")*
Aparte de Filtros para Agrícola - Agrícola, (13/8 - 12 UNF de 1")
1 3/8 - 12 UNF (1" flow)

- AD = Alta Diámetro, como Gilbarco, Wayne y otros dispensarios (Roscas de 1-1/2" - 16 UNF (Flujo de 1")

Referencia de Colores les Ayuda para Identificación Rápida del Función del Filtro

Información de Seguridad

Instrucciones de Instalación Internacionales

Con Información del Torque Correcta

Funcionamiento

Código de Barra para Escanear

Control de Almacenaje

Underwriters Laboratories

Reconocido del EE.UU. y Canadá

ROJO

Filtración de Partículas Solamente

CAFÉ

Detección de Agua y Filtración de Partículas

AZUL

Detección de Separación de Fases "Anuncio" y Filtración de Partículas

VERDE

Detección de Separación de Fases, de Agua y Filtración de Partículas

Filtros para surtidores de combustible para Gilbarco®, Wayne® y otras marcas populares

Los filtros PetroClear® de tecnología avanzada están disponibles en un número de tamaños en micrones para mantener el combustible limpio y con buena fluidez.

“Alerta” de detección de separación de fases y eliminación de partículas

Filtros giratorios diseñados para eliminar partículas de combustibles con mezcla de etanol y proteger contra la separación de fases.

Detección de separación de fases, detección de agua y eliminación de partículas

Filtros giratorios diseñados para eliminar partículas y detectar agua libre y emulsificada proveniente de gasolina pura o gasolina con mezcla de etanol, y para proteger contra la separación de fases.



Flujo: 3/4"

Rosca de montaje: 1" – 12 UNF

Flujo: 1"

Rosca de montaje: 1.5" – 16 UNF

Flujo: 3/4"

Rosca de montaje: 1" – 12 UNF

Flujo: 1"

Rosca de montaje: 1.5" – 16 UNF

Tipo de filtro	Giratorio
Tipo de medio	*Celulosa con núcleo químico
Tamaño en micrones	10 o 30 micrones (nominal) (Nominal = 75% de eficiencia)
Espesor de la estructura	0.020
Material de la junta	Buna N
Presión de colapso (mínima)	150 psid (10.3 bar)
Presión de ruptura (mínima)	A - 250 psi (17.2 bar) AD - 500 (34.5 bar)
Temperatura operativa máxima	250°F (139°C)
Temperatura operativa mínima	-20°F (-28.9°C)
Otras características	reconocido por UL

Tipo de filtro	Giratorio
Tipo de medio	*Celulosa con medios super absorbentes y núcleo químico
Tamaño en micrones	10 micrones (nominal) (Nominal = 75% de eficiencia)
Espesor de la estructura	0.020
Material de la junta	Buna N
Presión de colapso (mínima)	150 psid (10.3 bar)
Presión de ruptura (mínima)	D - 250 psi (17.2 bar) AD - 500 (34.5 bar)
Temperatura operativa máxima	250°F (139°C)
Temperatura operativa mínima	-20°F (-28.9°C)
Otras características	reconocido por UL

Los filtros PetroClear no deben utilizarse en aplicaciones de combustibles para aviación.

Los filtros PetroClear no deben utilizarse en aplicaciones de combustibles para aviación.

NOTA: Si experimenta frecuentes cambios de filtros, se recomienda que haga analizar las muestras de combustible para determinar la fuente de contaminación, tal como agua, suciedad, herrumbre, bacterias, separación de fases, etc.

“Alerta” de detección de separación de fases y eliminación de partículas

Filtros giratorios diseñados para eliminar partículas de combustibles con mezcla de etanol y proteger contra la separación de fases.

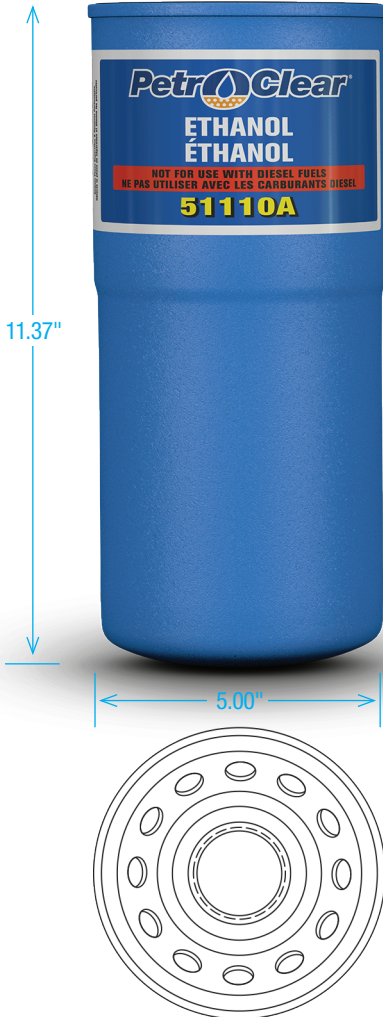

Flujo: 1"

Rosca de montaje: 1.5" – 16 UNF
Tipo de medio: Celulosa con núcleo químico

Tipo de filtro	Giratorio
Tamaño en micrones	10 micrones (nominal)
Espesor de la estructura	0.020
Material de la junta	Buna N
Presión de colapso (mínima)	150 psid (10.3 bar)
Presión de ruptura (mínima)	250 psi (17.2 bar)
Otras características	UL reconocido

Los filtros PetroClear no deben utilizarse en aplicaciones de combustibles para aviación.

Referencia cruzada

*No es un cierre positivo

CIM-TEK	PetroClear	CIM-TEK	PetroClear
70806 / 300-02	40502P	70075 / 450HS-10	40910W-AD
70808 / 400-02	40502P-AD	70076 / 450HS-30	40930W-AD
70122 / 300MB-10	40510A	70063 / 800HS-10	51110W
70120 / 400MB-10	40510A-AD	70068 / 800HS-30	51130W
70122 / 300MB-10	40510D	70019 / 800-10	51110P
70120 / 400MB-10	40510D-AD	70020 / 800-30	51130P
70059 / 300HS-10	40510W	30002 / E10	PCP-E10
70064 / 300HS-30	40530W	30004 / E30	PCP-E30
70010 / 300-10	40510P	30033 / EHS 10	PCW-E10
70012 / 300-30	40530P	30036 / EHS 30	PCW-E30
70060 / 400HS-10	40510W-AD	30001 / 500B-30	L3561F
70065 / 400HS-30	40530W-AD	30008 / E-1300-10	61810EP
70015 / 400-10	40510P-AD	30009 / E-1300-30	61830EP
70016 / 400-30	40530P-AD	30034 / E-1300HS-10	61810EW
70002 / 200E-10	40810P-DV	30037 / E-1300HS-30	61830EW
70046 / 200E-30	40830P-DV	50003 / 200H-3/4	75N1-12
70004 / 200AE-10	40810PA-DV	50181	75N1-12A
70045 / 200AE-30	40830PA-DV	50002 / 200H-1	1.0N1-12
70003 / 250E-10	40910P	50004 / 200AH	1.0N1-3/8-12
70094 / 260-10	40910P	50109	1.0N1.5-16
70061 / 260AHS-10	40910WA	50163	1.5N1.5-16
70066 / 260AHS-30	40930WA	50011	D2.0N1.5-16
70005 / 250AE-10	40910PA	50032	1.0N1 5-16AD
70089 / 250AE-30	40930PA	60001 / Pre-Vent	TV-2
70034 / 450-10	40910P-AD	60003 / Pre-Vent Cap	TV-RC-2
70027 / 450-30	40930P-AD	50001 / 200C	TC 1-12

Adaptadores

Consulte la sección referencia de este manual de filtración para obtener más información sobre la disponibilidad y las especificaciones del adaptador.



200 South Fourth Street | Albion, Illinois 62806-1313
Gratis: 800-851-5990 | Fax: 800-545-1508
Fuera de EE. UU.: 618-445-6011 | Fax fuera de EE. UU.
y Canadá: 618-445-4040 PetroClear.com





TECHNICAL INFORMATION

White Papers & Technical Specifications

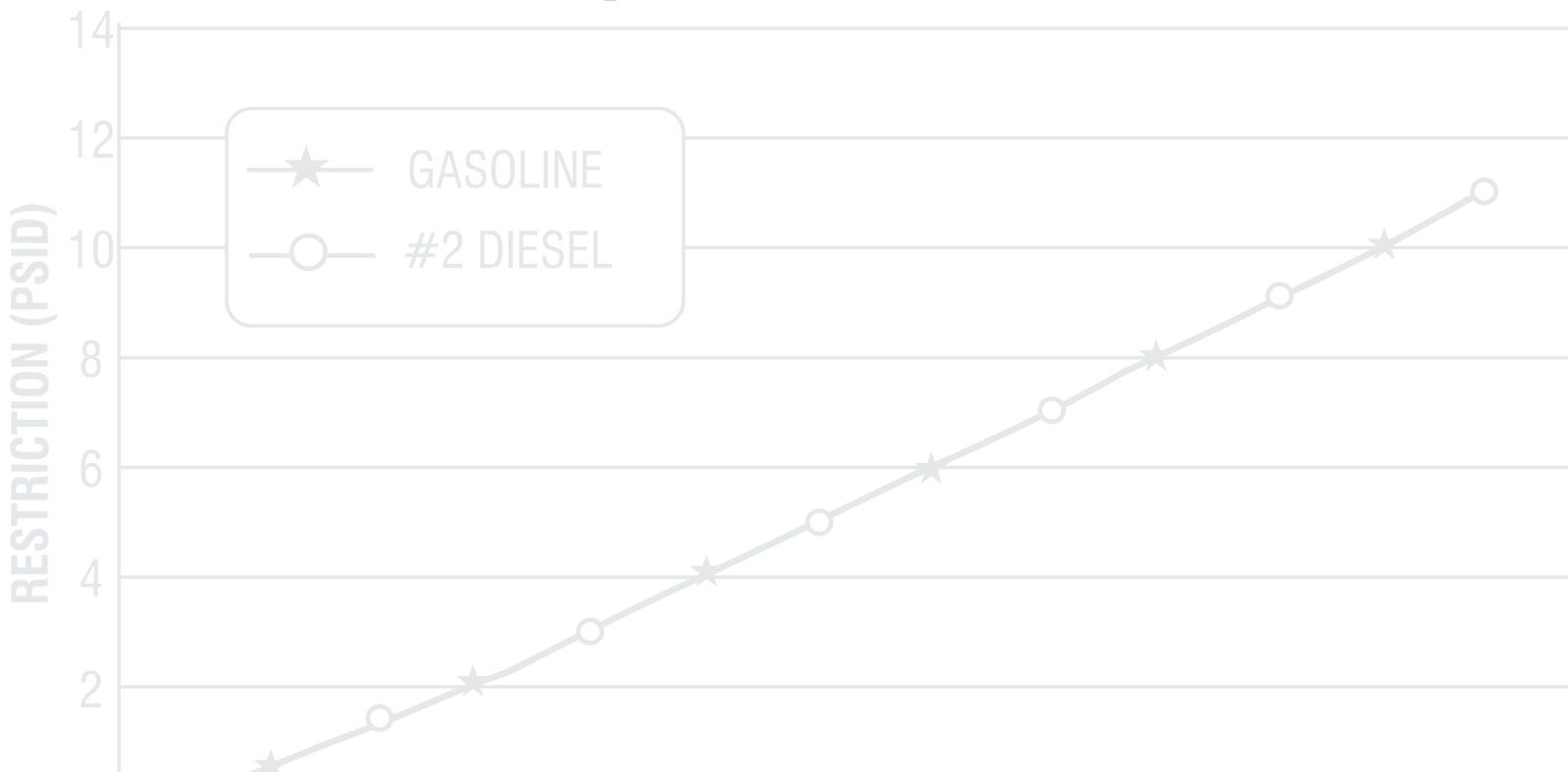

Profits Begin at the Pump In More Ways Than One

by Dwight Rutledge

Fuel site operators are keenly aware of the difference between what they sell at the forecourt and what they sell inside the c-store—especially with regard to profit margins. While many consumers assume that fuel sites rake in big profits of a dollar or more per gallon at the pump, industry sources have confirmed what fuel retailers already know: gross margins on gasoline (the markup before expenses are factored in) have averaged 20 cents per gallon (7 percent) over the past five years. After expenses, profits are pennies per gallon, and a fuel site usually makes an average of about 30 cents total on a typical fill-up.

Those low-margin sales, however, are the drivers for higher-margin sales inside the c-store. According to industry data, 58 percent of a store's total sales on average are motor fuels, but those sales only account for 34 percent of profit dollars. Retailers know that if they can attract a consumer to the fueling island, they have a much better chance to convince that consumer to go inside the store and make additional purchases.

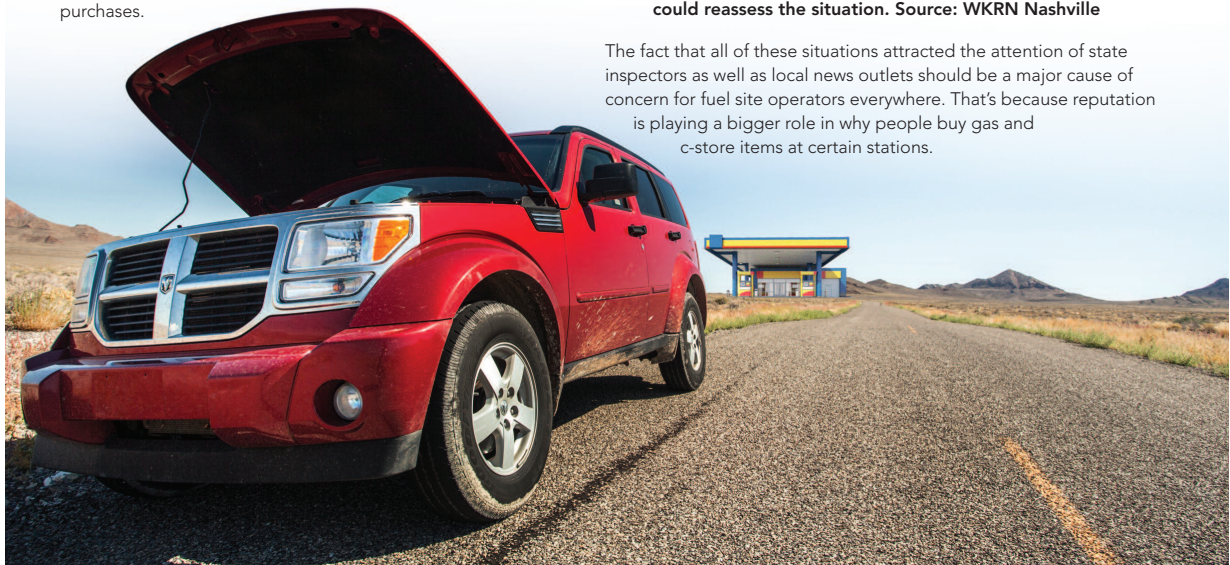

The High Cost of Contaminated Fuel

Because gas consumers are extremely price sensitive, cutting profit margins even closer to the bone on fuel is one way to draw business away from the competition. But what about the ways a fuel site operator can drive business away? A big one has nothing to do with the price of the fuel and everything to do with the quality of the fuel. News reports about a few recent incidents that have occurred at fuel sites across the United States illustrate the importance of taking steps to avoid dispensing contaminated gas.

- Customers at a gas station in Rome, Georgia, claimed they got bad gas that was contaminated with water. One of them missed a day of work, spent another two days draining his vehicle's fuel tank and eventually had to spend thousands of dollars to replace the entire fuel system. An investigator confirmed the contamination claims and the Georgia Department of Agriculture shut down the station's pumps until all of the tanks and lines could be drained and cleaned or replaced. Source: WSB-TV Atlanta
- An alderman in Milwaukee, Wisconsin, alerted his constituents about the shutdown of a fuel station that was selling gas mixed with water. Consumer complaints prompted state officials to send an inspector to the site and stop the fuel operation until faulty tanks could be repaired and tested. One customer who bought bad gas had to have her spark plugs replaced and her fuel system cleaned, which cost about \$800. Source: FOX6 Milwaukee
- A gas station in Gallatin, Tennessee, had to stop selling fuel after the Department of Agriculture responded to a series of customer complaints about bad gas. One complaint came from a woman who said she was a loyal customer until she incurred over \$1,000 in auto repair bills. A lab analysis found that the station's fuel "failed the phase separation test and workmanship test, which usually indicates water in the fuel." Inspectors ordered the station to cease its fuel operation for several weeks until they could reassess the situation. Source: WKRN Nashville

The fact that all of these situations attracted the attention of state inspectors as well as local news outlets should be a major cause of concern for fuel site operators everywhere. That's because reputation is playing a bigger role in why people buy gas and c-store items at certain stations.

NOTE: If you experience frequent filter changes, it is recommended that you have fuel samples analyzed to determine the source of contamination, such as water, dirt, rust, bacteria, phase separation, etc.

RETAIL OPERATIONS

Imagine the damage to a fuel site's reputation when consumers show up to fill their tanks and are greeted with roped-off fuel islands and notices of a state-mandated shutdown of the fueling operation—or worse, if hundreds or thousands of consumers learn about it on the local news.



Brand Reputation Matters—A Lot

The results of one industry survey indicate that while most consumers still say they buy gas based on price, they are almost twice as likely as they were just six years ago (57 percent vs. 31 percent) to seek out a fueling station based on brand. According to another survey, more than two in three Americans (71 percent) believe that convenience stores share their community's values and do business the right way.

Imagine the damage to a fuel site's reputation when consumers show up to fill their tanks and are greeted with roped-off fuel islands and notices of a state-mandated shutdown of the fueling operation—or worse, if hundreds or thousands of consumers learn about it on the local news. Obviously, fuel purchases are impossible during these nightmare scenarios, but as the numbers indicate, high-margin c-store purchases can be in serious jeopardy as well—for the duration of the shutdown and even well after the situation has been resolved.

The best way to avoid an interruption in fueling operations caused by contaminated gas is to put the highest priority on a strong quality assurance program at the pump. At the core of any such program is dispenser filtration. The basic function of fuel dispenser filters is to prevent a variety of contaminants from being pumped into your customers' vehicles, including water, which was the culprit in all three fuel-site shutdowns referenced earlier.

The Many Benefits of Dispenser Filtration

Water intrusion can happen at various points in the distribution cycle, from refining and delivery to condensation within the storage tank. Phase separation is a condition that occurs when the presence of water causes the alcohol to separate from the gasoline solution in a fuel tank. When alcohol in the fuel absorbs the water and becomes oversaturated, it drops to the bottom of the tank and closer to the pump intake tube, which increases the likelihood that it will be distributed to consumers.

Serious engine damage can result from this type of fuel contamination as well as from the presence of particulates. Even the smallest particulates can create abrasion in an engine's components and lead to long-term performance problems that a mechanic can trace back to contaminated gas. Quality fuel dispenser filters that are changed at recommended intervals are a cost-effective way to mitigate the risk of customers experiencing costly engine problems due to fuel contamination.



In addition to preventing water and particulates from damaging customers' vehicles, a regular dispenser filter maintenance program can offer retailers an early warning about potential trouble in their site's fueling system. Corrosion within the storage tank is likely when debris that resembles coffee grinds appears in the filter media. Frequent filter clogging is another indication of a problem—either with the fuel or the tank—and filters with specific functionality will slow the flow of fuel when they detect phase separation, sense the presence of water or collect an excessive amount of particulate.

If there's anything that keeps a fuel site operator awake at night, it's the possibility of being the subject of a state regulatory inspection or a local news report initiated by an accusation of selling contaminated gas. A prolonged fuel island shutdown is bad enough, but much worse are the resulting consequences that include diminished sales of high-margin c-store items and long-term damage to the fuel site's reputation in the community. Given the increased levels of competition in today's retail fueling industry, it could be difficult if not impossible to recover from even one contamination incident. Establishing and maintaining a regular dispenser filter maintenance program is a comparatively small investment that brings big rewards: peace of mind for you and your customers as well as no disruption to your high-margin c-store sales. ■

[READ MORE](#) at FuelsMarketNews.com



Dwight Rutledge

Dwight is Business Development Manager at PetroClear, a Champion Laboratories brand dedicated to manufacturing fuel dispenser filters. He has over 35 years of experience in the petroleum-equipment industry. For more information, please visit www.petroclear.com.

NOTE: If you experience frequent filter changes, it is recommended that you have fuel samples analyzed to determine the source of contamination, such as water, dirt, rust, bacteria, phase separation, etc.

RETAIL OPERATIONS

Your Dispenser Filter Might Be Trying to Tell You Something

by Dwight Rutledge

Imagine if a routine, relatively inexpensive part of a retail fuel dispenser could tell you when conditions inside your underground storage tank (UST) are deteriorating to the point that operations could be compromised. Well, such a part exists. It's a dispenser filter.

Dispenser filtration is not only a fuel site's last line of defense against dispensing contaminated fuel, the filter itself often presents one of the first indications of a serious, systemic problem. Although most fuel retailers view filter maintenance as a cost-of-doing-business expense, filter maintenance that is performed regularly offers operators an additional benefit: the opportunity to observe signs of trouble in the fueling system and initiate corrective actions.

Making the Contamination Connection

There are two common and serious conditions that occur inside a UST that can destroy fuel quality along with customer loyalty: phase separation in ethanol-blended fuels, and corrosion in tanks containing ethanol, ultra-low sulfur diesel or biodiesel. Both of these problems can be detected in a dispenser filter engineered to filter particulate or react to phase separation.

“ ”

Dispenser filtration is not only a fuel site's last line of defense against dispensing contaminated fuel, the filter itself often presents one of the first indications of a serious, systemic problem.



FMN Magazine 63 FuelsMarketNews.com

NOTE: If you experience frequent filter changes, it is recommended that you have fuel samples analyzed to determine the source of contamination, such as water, dirt, rust, bacteria, phase separation, etc.

RETAIL OPERATIONS

Your Dispenser Filter Might Be Trying to Tell You Something



“The vulnerability of fuel to water contamination creates an extremely challenging quality-control situation for fuel operators. Thankfully, dispenser filters not only help prevent the distribution of contaminated fuel, they help signal fuel site operators to the development of fuel quality problems and potential infrastructure issues.”

Occurrences of corrosion in storage tanks are on the rise. As demand for renewable fuels increases, biodiesel and ethanol become a larger part of the supply. As such, corrosion incidents are increasing. Tanks containing ultra-low sulfur diesel (ULSD) pose a particular challenge. A 2016 study conducted by the U.S. Environmental Protection Agency Office of Underground Storage Tanks found that of tanks containing diesel, about 83% of the USTs in the study were reported to have moderate or severe corrosion.

Clean biodiesel, ULSD and ethanol fuels are themselves not the source of tank corrosion. However, petroleum products are extremely susceptible to contamination. Biodiesel contains fatty acid methyl esters. These molecules grow organic microbes, which eat away at the tank. Water has a similar effect on ULSD—bacteria and fungi flourish in the presence of water, and they need very little of it to thrive. Water also ruins ethanol blends. Ethanol attracts and absorbs water to create corrosive acetic acid. Worse yet, water causes an ethanol blend to complete phase separation.

Unfortunately, water intrusion happens during many points along the way to distribution: during refining, during delivery, when it rains, as groundwater run-off, as in-tank condensation and more. The vulnerability of fuel to water contamination creates an extremely challenging quality-control situation for fuel operators. Thankfully, dispenser filters not only help prevent the distribution of contaminated fuel, they help signal fuel site operators to the development of fuel quality problems and potential infrastructure issues.

It's Time to Listen to Your Dispenser Filter When...

Dispenser filters are the canaries of the forecourt. By performing a few primary functions—capturing particulate, sensing water and detecting phase separation—dispenser filters can cue operators to deteriorating product quality and infrastructure. (Note: not all filters perform all functions. Therefore, proper filter selection is critical to maximizing your level of protection and warning.)

For instance, as fuel flows into a Phase Separation Detection, Water Sensing and Particulate Removing dispenser filter, the filter collects debris and senses water and phase separation. The filter alerts operators to contamination by disrupting the flow of fuel in the following ways:

- As the filter collects particulate, flow becomes restrained. If this happens earlier than planned maintenance intervals, then it is likely an indication of a problem with the fuel, storage and dispensing equipment, or both. For example, when the flow of diesel fuel decreases to about half its normal rate, the dispenser filter needs to be replaced.
- If fuel that has completed phase separation passes through the filter, a specially treated polymer inside the filter expands and congeals, increasing the total differential pressure, which significantly slows the flow of the fuel.
- Similarly, if the filter senses water, the filter reduces the flow.

A used dispenser filter offers a snapshot of the quality of the fuel recently pumped through the dispenser and, therefore, is an indication of the conditions inside the tank. By examining the contents of a used dispenser filter either on-site or in a lab, fuel site operators and technicians obtain insights to the factors contributing to deficiencies in fuel quality. Indications of fuel contamination or tank corrosion include:

- Flow becomes restricted prior to planned maintenance intervals due to a clogged dispenser filter
- Corrosion of interior metal filter parts
- Particulate in the filter—solid or semi-solid contaminants that resemble a reddish-orange metal and/or scaly, granular deposits
- Microbial slime in the filter
- Foul odor that smells like rotten eggs
- Extreme discoloration/leopard spotting

Last Line of Defense

Fuel that contains particulate or that has completed phase separation will damage dispenser components and automotive engines. High Pressure Common Rail fuel-injection systems with small, precision-crafted components are particularly susceptible to microscopic contaminants. Fuel that has completed phase separation can cause a vehicle to experience an immediate failure that requires it to be towed from the fuel site.

Dispenser filters represent the last chance to capture contaminants prior to fuel entering a vehicle. The lower the filter's micron rating, the more particulate the filter will capture. With regard to ULSD, the Clean Diesel Fuel Alliance recommends that fuel site operators install a nominal 5-micron filter on the dispenser. Further, if the UST has chronic water problems, the Clean Diesel Fuel Alliance reports that a 5-micron water absorbing filter in an equivalent pore size may be needed. PetroClear's 40505W-AD dispenser filter, for example, captures particulates as small as five microns and prevents them from entering and damaging a vehicle's fuel injection system. The filter also senses when elevated levels of water are present in the fuel and alerts the fuel-site

RETAIL OPERATIONS

Your Dispenser Filter Might Be Trying to Tell You Something

operator through slow-flow dispenser operation that the fuel contains potentially damaging amounts of water that can cause bio contamination and poor lubricity.

Fuel dispenser filters, both as a critical quality control measure and as a reference point for conditions inside the UST, deliver a strong value for their cost. Fuel site operators who heed the filters' warning and pivot to rectify an underlying cause will position themselves to grow customer loyalty and establish stronger operations over the long term. ■

How Micron Ratings Measure Up

Dispenser filters feature a micron rating which is an indication of the size of particulate it is capable of capturing. A micron, also known as a micrometer, is a unit of measurement that is equal to one-millionth of a meter or 1/25,000th of an inch. Generally speaking, the human eye can see substances as small as 40 microns.

The lower a filter's micron rating is, the greater its ability to capture particulate. For instance, a 5-micron filter will capture particulate smaller than a dispenser filter with a 10- or 30-micron rating. As engine technologies grow increasingly sophisticated, thorough removal of particulate from fuel will be part of a strong quality assurance program.

Many states require fuel sites to utilize dispenser filters with a specific micron rating, and many dispenser manufacturers include dispenser filtration requirements in their warranty statements. Check with your local environmental officials and dispenser manual to obtain your site's dispenser filtration requirements.

Object at Micron Scale

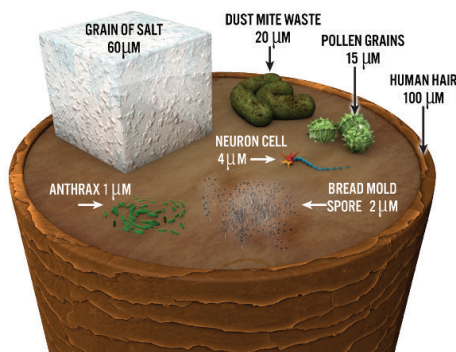

Dwight Rutledge
Dwight is Business Development Manager at PetroClear, a Champion Laboratories brand dedicated to manufacturing fuel dispenser filters. He has over 35 years of experience in the petroleum-equipment industry. For more information on PetroClear, please go to www.petroclear.com.

argus
argusmedia.com

Argus Fall Industry Events

Argus Methanol Forum
September 12-14, 2018
Join more than 250 market participants from around the globe to hear industry perspectives and gain insight into methanol, MTO and olefins.
www.argusmedia.com/Methanol-Forum

10th Argus Americas Petroleum Coke Summit
September 12-14, 2018
Be part of the largest gathering of senior petroleum coke market participants at the start of the contracting season.
www.argusmedia.com/Americas-Petroleum-Coke

Argus California Carbon & LCFS Summit
October 22-24, 2018
Join over 200 of your peers to better understand the changing dynamics of California's carbon and fuels markets as well as federal and emerging state emissions programs!
www.argusmedia.com/California-Carbon

Reserve your spot today!
Use code **FMN2018** at checkout
to **save 15%**

NOTE: If you experience frequent filter changes, it is recommended that you have fuel samples analyzed to determine the source of contamination, such as water, dirt, rust, bacteria, phase separation, etc.

FILTER NOW OR PAY LATER

By Dwight D. Rutledge

Webster defines “contaminate” as to render something impure or unsuitable for use by contact or mixture with something unclean, bad, etc. Webster defines “water” as transparent, odorless, tasteless liquid, a compound of hydrogen and oxygen (H₂O), that can be a gas, a liquid, or a solid upon freezing at 32 degrees Fahrenheit. Because of ability to assume different forms, water contamination in fuel storage can be a serious problem and demands continuous attention. If ignored, the contamination in your fuel system will eventually take its toll on operating cost for unscheduled repairs as well as lost revenues associated with equipment down time. Also, new engine warranties do not cover damage caused by fuel contamination! Water is not only a major culprit in itself, but it also acts as a magnet attracting other contaminants commonly found in fuel storage systems. It is important to recognize the consequences of lax fuel management and how it affects your equipment. Knowledge of your fuel storage systems is the first step to dispel the mystery of how, where, and when you receive water contamination. You will then begin to understand how to regain control of your system.

Water invades fuel systems in a variety of ways, such as through vents, defective gaskets at sampling points, condensation from temperature change and exposure to air, and, last but not least, fuels delivered from the refinery containing water. Small quantities of water that mix into solution with fuel are referred to as “dissolved water,” generally less than 100 ppm., or .01%. You can compare dissolved water in fuel to humidity in the air. There is a limit to the amount of dissolved water fuels can hold; above that limit or saturation point the fuel will begin to visually show the presence of water as a clouding of the fuel. As additional water is introduced to fuel, emulsification of the water into the fuel takes place, causing a general discoloration of the fuel. Excess emulsified water above saturation levels will separate out and settle to the bottom of the reservoir. It is then referred to as free water, which is easily detected.

By better understanding what is going on within your fuel storage system, you can begin your means of combating the degradation process of your fuel. Water contamination demonstrates destructiveness in the

following terms: poor engine performance; pump and injector wear; reduced fuel economy; excessive exhaust emission; microbiological activity which causes filter plugging; fuel/water emulsion; tank corrosion; sediment and sludge formation, as well as fuel system freeze-ups during cold winter months.

Equipment and fleet managers realize that high-tech diesel and gasoline engines demand clean, dry fuel to operate efficiently. Electronic fuel injection systems depend on proper lubrication provided by clean, dry fuel. Without this, injection system wear accelerates and precision components are subject to serious damage and can result in catastrophic failures.

Water sensing and particulate filtration at the dispenser is your first line of defense in an applied preventative maintenance program. Pre-cleaning the fuel will extend the service life of primary and secondary filters installed on the engine. No fuel jobber will admit selling you contaminated fuel. However, as we all know, it happens whether they know it or not. To detect the presence of water, equipment and fleet managers take samples from the bottoms of their storage tanks. They also use a water finding paste to check for the presence of currently accumulated water. The results provided by the above means can give you a false sense of security because neither method thoroughly indicates the presence of emulsified water in fuels. Equipment and fleet managers are aware that most fuel storage tanks can and often do contain free water at the bottom of the tank. Therefore, the pick up point for their pumps is 4 to 6 inches above the tank bottom. However, when fuel is delivered, the turbulence caused during unloading causes water to mix with the new fuel.

Most often at this point, the fuel supplier will receive a phone call from his customer making him aware that since the delivery of fuel, all equipment is experiencing problems.

Now the fuel supplier must convince the customer that the fuel was not wet. Most veteran equipment managers will try to schedule their fuel delivery late on a Friday afternoon, allowing the recently disturbed fuel

NOTE: *If you experience frequent filter changes, it is recommended that you have fuel samples analyzed to determine the source of contamination, such as water, dirt, rust, bacteria, phase separation, etc.*

FILTER NOW OR PAY LATER (Continued)

system a couple of days to resettle. Proper fuel storage tank installation procedures include the slight tilting of the tank, therefore allowing the pick up tube to be on the high end of the tank. Water, being heavier than fuel, will drop to the low point where it accumulates and can later be pumped or drained off. The airspace in the storage tank above the fuel level contains water vapor condenses on these surfaces. In other words, what you can't see can definitely harm you.

As you can see, nothing should be assumed with regards to your fuel management program. Water removing filters, such as the Petro Clear Filter, are considered to be an excellent preventive maintenance tool for water sensing at the point of delivery. At the same time they alert the operator when it is time to service the filter. As the Petro Clear Filter begins to reach

its water holding capacity, the pleated media within the filter begins to expand, restricting the flow rate and alerting the operator to service the filter as the flow rate continues to diminish. What kind of filter life can be expected depends solely on the condition of the fuel. If you put a pencil to the economics, this customer will pay less than half a cent per gallon for clean and dry fuel. Insurance protection for pennies!

As long as you continue to practice good maintenance, combined with regular testing of fuel delivery samples, the result will be an excellent fuel management program.

Your efforts will result in improved equipment operation, lower operating cost, less down time and more profits on the bottom line.

FILTER AWAY UNCERTAINTIES

Dispenser filters provide a window into your tanks

by Keith Reid

For many retailers, dispenser filters are looked upon as an afterthought or necessary evil. Filters require maintenance, and when they are near capacity they slow down throughput at the islands. Filters also touch on a sensitive area for retailers and their fuel suppliers — the very suggestion that their fuel could somehow be tainted. The result is often ambivalence. It is also easy to assume that “my gas is always fine” or that a “little water” doesn’t really hurt anything.

“A lot of retailers think a filter is the most insignificant part of a system, but actually it’s their last line of defense,” said Dwight Rutledge, master agent for the PetroClear product line, Champion Laboratories Inc., Albion, Ill. “And a lot of the smaller operations would plug the filter mount if they could. One retailer even joked that he, ‘sold water and gas for the same price.’”

While the quality of the gasoline is generally high in the United States, and some contamination can be overlooked without it causing too many problems, filters provide a necessary last line of defense for the exceptions to the rule. No retailer wants to have a reputation in the local market as having bad fuel, and increasingly there are bottom-line reasons to pay attention to the issue.

Modern automobiles are far less forgiving of contaminated fuels than cars in the past, and cleaning clogged injectors, or, in a worst case scenario, replacing an engine can be quite expensive. Auto manufacturers void the warranty for such fuel-related repairs,

and upstream marketers are increasingly shifting fuel related liabilities down to the retailer.

“Companies like Chevron, Conoco, Diamond Shamrock, Marathon and BP Amoco, to name a few, feel they deliver good fuel and know that dispenser filters work,” said Rutledge. “They have told the retailers, basically, that if you have a problem and you are not using a filter, then call your personal insurer and not us if a customer has a problem.”

Refiners do not necessarily sell wet fuel, but heating and cooling cycles throughout the distribution process allow water to enter the fuel during distribution. When the fuel reaches the retailer’s tanks, the slow accumulation can add up over time.

“In the United States we’re basically blessed with clean fuel, at least compared to the less developed regions in the world,” said Bob Burns, vice president of sales, Central Illinois Manufacturing/Cim-Tek, Bement, Ill. “However, after the fuel comes out of the refiner, it’s always in an aboveground or below ground tank. You are going to have condensation and the problems that come with it. Anybody can get a bad load of fuel, or have a good load poorly delivered while it’s raining.”

The quality of the independent haulers, routinely used to transport the fuel in all but the largest operations, can also have a significant impact on fuel quality.

“There was one retailer in San Antonio who had some severe problems, with clogged filters and slow

flow on a weekly basis,” said Rutledge. “He drained his tanks and found all sorts of stuff in there — rags, paper towels, all sorts of chemicals. We must have spent \$20,000 and they spent \$20,000 getting to the bottom of it, and we traced the problem through many sources all the way back to the refinery. At the loading terminal you have 30 micron filtration, which is nominal, and all sorts of contaminants start working into the picture from there.”

While particulates are likely the most common problem addressed with filtration, water is the root of most evil when it comes to fuel contamination problems. Water itself can cause operational problems with automobile engines, and it is key for the formation of both biological and particulate contaminants. While there are products available to help detect water accumulation in tanks, the changing face of retail petroleum reduces their effectiveness.

“These high-volume sites that do 100,000 gallons every two weeks with a couple of drops every other day, the fuel never settles down,” said Rutledge. “This makes it hard to accurately test for water build-up in the tanks.”

Water also leads to phase separation, in which a chemical reaction occurs that separates the contents of the tank into gasoline, alcohol and water.

“Any water will start phase separation,” said Burns. “At the least, it can cause you to fail an octane test.”

Fortunately, significant phase separation is not common — but when it occurs it can be serious.

FUELS & FUELING

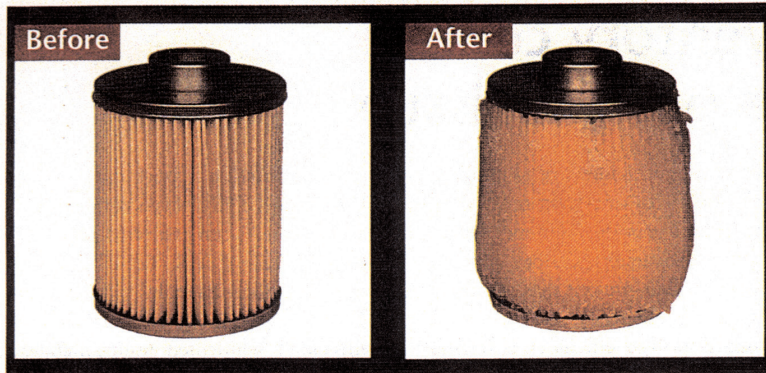

A water-media filter core before and after saturation — the reason behind slow flow.
(Photo courtesy of Champion Laboratories)

“Alcohol will absorb only so much water before phase separation occurs, separating the tank’s contents into gasoline, water and alcohol,” said Rutledge. “It takes a pretty significant amount of water for this to happen, probably 100 gallons of water in a 10,000-gallon tank, but when it does you can end up pumping pure alcohol into a customer’s tank. When that happens, it burns up the engine.”

While filtration does little good once phase separation occurs — for either water or alcohol — a water-trapping filter using a synthetic, super-absorbent polymer medium can indicate the onset of a problem through the need for frequent replacement.

Water is also the root source of biological fouling in tanks and dispensing systems.

“Bugs live in the water-gas interface level,” said Burns. “Water provides them with a growth medium and they can then feed on just about anything. There are bugs that thrive on discarded plutonium reactor rods. We also took away many of the things that naturally discouraged growth, such as lead and aromatics, and added oxygenates which help promote growth.”

Water causes corrosion which creates rust particulates, which is perhaps the filtration issues retailers are most aware of and accepting when using dispenser filters. Particulates are fairly easy to treat using traditional filter media.

The widespread use of fiberglass

tanks has reduced the particulate formation at the retail site, though metal fittings and components still contribute to the problem. Metal pipes, fittings and tanks still are abundant in the distribution system.

“We are getting more and more particulates these days,” said Burns. “The refineries are being run at capacity and the product is not being given a chance to cool and settle. The volume also impacts the particulates at the retail site, since there are stations that five years ago did 50,000 gallons a week and now they’re doing 100,000 gallons. The product is under constant motion stirring up the tank bottom.”

Burns also notes that the use of ethanol, currently as an oxygenate alongside MTBE in national clean-air programs, can also magnify particulate problems.

“With alcohol additives, you basically clean your tank for the first 180 days after you start using it,” said Burns. “Alcohol is a stimulant; it changes the dynamics of the tank and cuts loose any flaking rust as well as grease and other build-up.”

Ethanol use is only expected to increase with pending bans on methyl tertiary butyl ether, and the political drive to keep oxygenates alive by substituting ethanol on a national level.

Periodic tank cleaning can help take care of particulate build-up, with tanks holding both traditional and ethanol-laden gasolines.

Continued on page 39

Make life easy for your filters

Filters should be a last line of defense, and not a substitute for poor tank maintenance. The key, of course, for most of the issues filters address is to keep the water out of the tanks and eliminate potential tank problems while they are still in their initial phase. Here are some tips:

1. Give your tanks a chance to settle before you test for water. Test no sooner than four hours after a delivery to get better results.
2. Make sure to take the fuel samples for water testing off the bottom. Use a “fuel thief” or “bomb” that can be set to collect the sample at a set depth.
3. Be aware of how your tanks have actually settled into the ground. It helps to test for contaminants at both ends of the tank, not just the end that is supposed to be lower.
4. Consider the use of electronic water alarms and sensors.
5. Prepare to pre-clean your tanks for a switch to ethanol fuel.
6. Make sure to clean out new tanks and treat them with biocides up front. Periodically clean out tanks and retreat as convenient, or as problems are indicated.
7. If filters are clogging regularly, look at what they have to say. Quality filters do not clog without an underlying problem, and solving the initial problem is usually easier and less expensive than ignoring it.

FUELS & FUELING

Continued from page 35

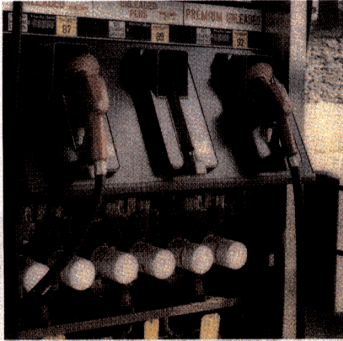

For liability protection and tank diagnostics, filters are hard to beat.
(Photo courtesy of Cim-Tek)

Burns also states that there is another water/alcohol issue that retailers need to consider.

“Water and alcohol form a substance we call ‘water alcohol,’” said Burns. “Traditional water-capture media will not see this as water because of its molecular differences. Car engines do not run well on this, and we have developed a filter to meet this need.”

Filters can serve as more than a “necessary evil.” They can serve as a diagnostics tool to help identify and solve systemic problems before they get out of hand. One complaint from retailers is that filters “always clog up” or “slow down fueling.” When they do, with quality filters, they are just doing their

job. Filters are designed to provide slow flow as a diagnostic and maintenance aid to indicate that it is time to change a filter that is at capacity. This should also be a warning sign to the retailer that they have a problem in the tanks that needs attention.

Champion Labs is working to get this message across to its customers.

“We’re starting a campaign of distributing filter wrenches with a cutter attached, so that retailers can open up the filter and see for themselves what is causing the filter to clog,” said Rutledge.

Necessary evil or proactive diagnostics tool, dispenser filters can help save retailers and their customers a lot of trouble down the road. 

NOTE: If you experience frequent filter changes, it is recommended that you have fuel samples analyzed to determine the source of contamination, such as water, dirt, rust, bacteria, phase separation, etc.



Technically Speaking

Petroleum dispensing filters: The Last Line of Defense Against Fuel Contaminants

by Dwight Rutledge

Water in fuel storage systems can be a serious headache. It can cause poor engine performance, pump and injector wear, reduced fuel economy and excessive exhaust emission. Also, water in a fuel storage tank can allow microbiological activity that causes filter plugging, fuel/water emulsion, tank corrosion and sediment and sludge formation, as well as fuel-system freeze-ups during the cold winter months.

Water invades fuel systems in a variety of ways, including through vents; deteriorating tanks, pipes, gaskets and other components; and from condensation (from temperature change and exposure to air). Also, fuel may already contain water when delivered from the refinery, terminal or bulk plant.

Water can be detected by taking samples from the bottom of the storage tanks or by using a water-finding paste. But all too often, the results of those tests can provide a false sense of security. When fuel is tested at the terminal, it is often still warm. This means the fuel holds water in a tighter emulsion. Often, when the fuel cools off, some of the emulsified water separates from the fuel and becomes free water. Water removal through a petroleum dispensing filter is the last line of defense to ensure that customers receive clean, dry fuel.

Today's filter manufacturers have products available to remove water from a wide variety of fuel types. These filters contain super-absorbent polymers that encapsulate water molecules and store them inside the filter.

To best understand how a filter functions, it is important to look inside. The construction of spin-on filters requires several parts (See *Figure 1*).

- **Coil spring**—By compensating for normal variations in the height of the components, the coil spring maintains the element-to-backplate seal and prevents unfiltered fuel from bypassing the filtering element.
- **Metal end caps**—Most spin-on filters use metal end caps to seal the pleated paper element at both ends, top and bottom. A liberal amount of thermosetting adhesive creates a virtually indestructible, leak-proof bond between the end caps and paper element.
- **Metal shell**—Designed to withstand a system pressure far in excess of the normal operating pressure, the metal shell provides a leak-proof container for the filter element.
- **Filtering media**—This is the determining factor for fuel cleanliness. The filter media is comprised of super-absorbent polymers that capture water molecules. This provides a water barrier for the fuel stream. The level of filtration is determined by the media pore size, which can be customized to meet specific requirements.
- **Perforated metal core**—The metal center tube provides the strength and support to the pleated paper media. It enables the media to withstand high differential pressures when the filter approaches capacity.



- **Rubber sealing gasket**—This gasket provides a leak-proof seal between the element and backplate, preventing contaminated fuel from bypassing the element.
- **Cover and backplate assembly**—This assembly consists of a threaded backplate, a gasket retainer and a sealing gasket. The assembly is formed from thick, strong steel to prevent damage from minor pressure surges. The backplate threading provides the mechanism for attaching ("spinning on") the filter to the dispenser.

Contaminated fuel enters a spin-on type fuel dispenser filter through the inlet holes (See *Figure 2*). The fuel then passes through the filter media.

The filter media used in water removal is made of two layers. The first layer contains the super-absorbent polymer that captures the water molecules. The second layer, which is a blend of cellulose and synthetic fibers, captures the particulate contaminants. The clean fuel is then dispensed to the customer through the center-threaded port.

Spin-on filters are easy to maintain. As the filter begins to reach its water-holding capacity, the super-absorbent polymer within the media begins to expand. This expansion restricts the rate of flow and alerts the operator to replace the filter.

Nothing should be assumed about your fuel management program. Well designed filter components, along with a sound manu-

facturing process, can help eliminate concerns about fuel contamination.

How to select a good filter

A good petroleum-dispensing filter will provide reliable, long-lasting, high performance. To do this, a good filter should:

- Keep fuel clean by removing particulate contaminants.
- Provide superior water-removal capacity.
- Not promote bacteria growth.
- Be leak-proof.
- Be suitable for today's gasoline and diesel fuels.
- Be a proven winner.

Filters are designed to meet different customer requirements. Some filters remove particulate only, while others remove both particulate and water. In either case, the filters are rated by their capability to remove a particular sized particle. This is referred to as a *nominal micron rating*.

Water creates havoc in a fuel system. Some filters trap only small amounts of free water, while others remove a higher percentage of both *free and emulsified* water. Learn the water removal capabilities of your filter. Contact the manufacturer for more information about specific product features.

It is important to reiterate that for superior water-removal capacity, a filter must have media impregnated with a super-

absorbent polymer. Super absorbent polymers encapsulate water molecules and store them inside the filter. The polymer should be inorganic so it does not promote bacterial growth.

Make sure a filter is leak-resistant. Filter cans (metal shells) with epoxy coating on the inside are far less likely to develop pinhole leaks. These leaks develop due to the corrosive conditions that can occur when fuels

become unstable. Epoxy coatings are fuel-resistant.

Some filters are suitable only for one grade of fuel, while others can handle different grades as well as different types of fuel, including Diesel 1 and Diesel 2, ethanol, methanol and MTBE blends (reformulated fuels and oxygenated fuels).

A good filter should have a proven track record. If a filter has been effective for you, it has achieved its purpose.

Know the in-house design and production capabilities of the company with which you are dealing. Does the manufacturer have complete control over the design and production process as well as in-house testing? Control of this process usually means better responsiveness and higher quality products. Production lines should also be clean and well-maintained to ensure the highest quality filters.

Remember, research your options before purchasing a fuel-dispensing filter. Being selective will pay off many times over. ■

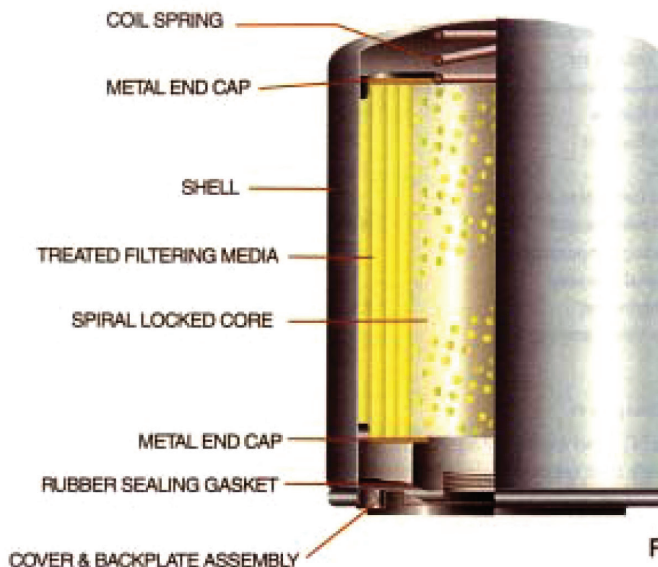
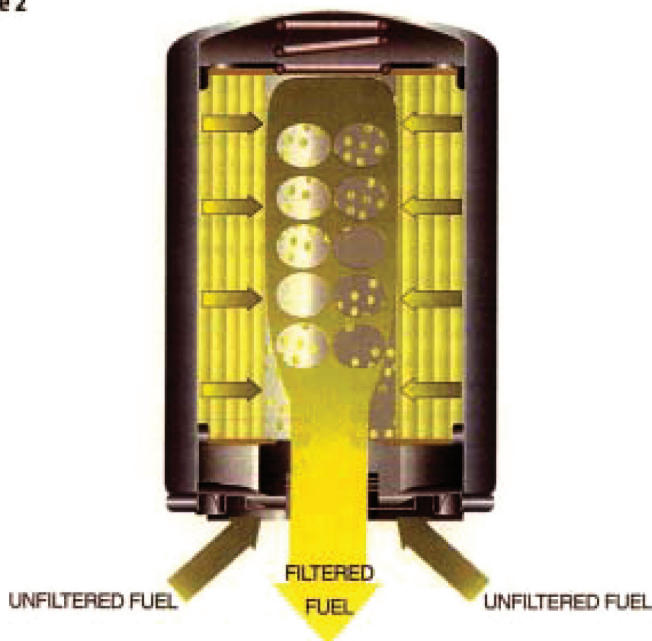

Figure 1

Figure 2



Biography

Dwight Rutledge is a Consultant and Master Agent for PetroClear Filters—a technological product of Champion Laboratories, Inc. He can be called at: 281-382-2852; or faxed at 281-360-3283. Dwight may also be reached at repddr@aol.com.

NOTE: If you experience frequent filter changes, it is recommended that you have fuel samples analyzed to determine the source of contamination, such as water, dirt, rust, bacteria, phase separation, etc.

	Technical Service Bulletin 89-5R

The Micron Rating for Fluid Filters

Back to [Technical Service Bulletins](#)

A micron rating for a fluid filter is a generalized way of indicating the ability of the filter to remove contaminants by the size of the particles. AIR FILTERS ARE NOT RATED BY MICRON SIZE.

The micron rating does not properly and fully describe either the efficiency or the contaminant-holding capacity of the filter.

What does the word micron mean? It is a unit of linear measure in the metric system used to measure distance from one point to another. It is used like the inch, foot, centimeter and millimeter to measure the length, width, or diameter of objects.

RELATIONSHIP OF PARTICLE SIZES BY DIAMETER

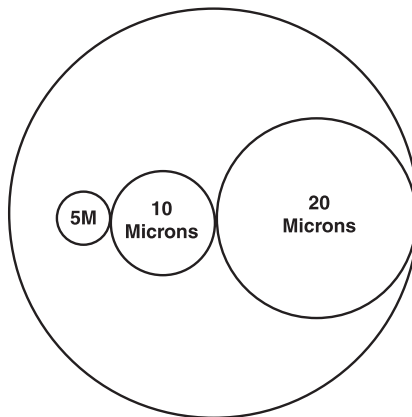

- 1 micron - 1 millionth of a meter
- 1 micron - 1 thousandth of a millimeter
- 1 micron - 39 millionths of an inch (.000039)
- 25.4 microns - 1 thousandth of an inch (0.001)
- 40 microns - visible without magnification
- 40 to 90 microns - diameter of human hair

A filter that is marked "10 microns" has some capability in capturing particles as small as 10 microns. However, there is no one accepted method to measure and describe the size of particles that a filter can capture or the total amount of particles that the filter can hold.

When you see the filter marked "10 microns," you will not know exactly what this means unless you also have a description of the test and standards used to determine the filter rating.

Filter micron ratings are often based on one of these methods, but with possible variations:

- A. Nominal Micron Ratings
- B. Absolute Micron Ratings
- C. Multi-Pass Beta Ratings

A) The Nominal Micron Rating usually means the filter can capture a given percentage of particles of the stated size. For example, a filter might be said to have a nominal rating of 90%, 10 micron size.

B) The Absolute Micron Rating is a single pass test and is usually obtained by passing fluid containing glass beads through a flat sheet of the filter material. Any beads that pass through are captured and measured.

C) The Multi-Pass Beta Rating has been accepted by many machinery manufacturers, as well as filter manufacturers, especially for filters used in fluid power applications; hydraulics, controls, transmissions, power steering and so forth.

The test uses contaminant specially graded by particle sizes added regularly in measured quantities to the fluid which is pumped continuously through the filter.

Measured samples of fluid are taken at timed intervals upstream and downstream of the filter. The contaminant in these samples is measured for particle sizes and the quantity of each size or ranges of sizes.

A ratio is then made for the intended micron rating:

An example: Particles upstream 10 microns and larger

Particles downstream 10 microns and larger

The Beta ratio would then be stated as Beta = 20

The multi-pass Beta ratio is accepted by many machinery manufacturers but not used in a public way by most of them to identify or specify their filters.

Some suggestions:

1. Use filters of high quality
2. Obtain filters by catalog listing, not just by "micro rating". Other important qualities should also be considered.
3. Pay close attention to service intervals and good service practices for the greatest economy of operation.

For additional information, contact:

Filter Manufacturers Council
P.O. Box 13966
Research Triangle Park, NC 27709-3966
Phone: 919/549-4800 Fax: 919/549-4824
Used Filter Recycling Hotline: 800/993-4583
www.filtercouncil.org

GLOSSARY OF TERMS

Absolute Filter Rating

The size of the largest spherical glass particle which will pass the filter under laboratory conditions. This rating is often misunderstood and misused in the filter industry and by its customers. It is widely believed that the absolute rating is an indication of the largest particles which will be found downstream of the filter. **THIS IS NOT SO.** The absolute rating simply determines the size of the largest glass bead a filter will pass under very low pressure differentials and non-pulsating flow conditions. It does not bear any relationship to the so-called absolute rating of the filter.

Alcohol Blends

Motor fuels that consist of a mixture of gasoline and alcohol, typically methyl alcohol or ethyl alcohol. Alcohol blends can operate in essentially the same type of internal combustion engine as gasoline. (High-speed racing cars burn pure alcohol.) Each fuel, however, has its own advantages and disadvantages. Alcohol creates less air pollution than gasoline, but alcohol-powered vehicles get fewer miles per gallon. In an effort to reduce crude oil consumption and simultaneously lower pollution and improve engine performance, refiners have developed various blends of gasoline and alcohol. The original blend marketed under the name of Gasohol consists of 90 percent gasoline and 10 percent ethanol (grain alcohol). Another blend, M-85 consists of 85 percent methanol (methyl alcohol) and 15 percent unleaded gasoline.

Beta Value

This value may also be referred to as a Beta Ratio or Filtration Ratio. It is simply a ratio showing the relationship between upstream and downstream particle counts of a specific size of particle for a filter. The Beta Ratio formula is used for calculating the efficiency of a filter media at removing particles, using base data from multi-pass testing. Example: A filter has 1000 particles, 10 micron or greater in the upstream going in, and 500 particles, 10 micron or greater downstream going out. $1000/500 = \text{Beta } (10) \text{ }^2 = 50\%$ efficiency.

Biocide

A chemical additive, poisonous substance that can kill living organisms in fuel systems.

Biodiesel Blend

Biodiesel Nontoxic, biodegradable replacement for petroleum diesel. Bio-diesel is made from vegetable oil, recycled cooking oil and tallow. Pure or 100 percent bio-diesel is referred to as B100 or "neat" bio-diesel. A bio-diesel blend is pure bio-diesel blended with petro-diesel. Bio-diesel blends are referred to as Bxx. The xx indicates the amount of bio-diesel in the blend (i.e. a B20 blend is 20 percent by volume bio-diesel and 80 percent by volume petro-diesel).

Breather Vent

Storage tanks containing volatile liquids, such as gasoline, need to "breathe." All space in the tank is filled with either liquid or vapor. Because the volatile liquid in the tank tends to increase and decrease in volume as the temperature of the product changes, and as product is added or withdrawn, the vapor space above the liquid level (the ullage) does not remain constant. These changes in the volume liquid, as well as the volume of vapors in the tank, must be accommodated. If they were not, a variation in vapor volume caused by temperature change would result in increased or decreased pressure on the walls of the tank. That's why atmospheric storage tanks must not be made air tight. Instead, air must get in.

BPT

British Pipe Thread. A tapered self sealing metric thread.

Buna-N

A synthetic rubber sometimes used in the seals and gaskets of petroleum nozzles, valves, swivels, and meters.

Capacity

The amount of contaminant a filter will hold before flow starts to slow, leading to excessive pressure.

GLOSSARY OF TERMS

Capacity-Water

There are no accepted and approved water capacity testing or reporting standards. Consequently, there is virtually no way to compare one element's capacity with another. It is also difficult to simulate a specific application in testing, making it hard to predict field performance. The discrepancies with water sensing media capacity are the result of the interplay among three main variables: flow rate, viscosity and the media itself.

EXAMPLE 1

(Effect of flow rate change): two identical elements, testing the same fluid, varying only the flow rate.
Element 1A: 3 gpm = 425 ml, Element 2A:
10 gpm = 360 ml (This 15% reduction in capacity is caused by changing on the flow rate.)

EXAMPLE 2

(Effect of viscosity change): two identical elements, maintaining the same flow, varying only the viscosity.
Element 1 B: 20 gpm, 200 SUS=250 ml, Element 2B,
20 gpm, 75 SUS = 550 ml. (Per ASTM Standard Viscosity - Temperature Charts, Diesel Fuel is approx. 40 SUS @ 55° F and 200 SUS @ - 10° F.)

Cellulose Media

A filter material made from plant fibers. Because cellulose is a natural material, its fibers are rough in texture and vary in size and shape. These characteristics create a higher restriction to the flow of fluids. See synthetic media for a comparison.

Collapse

Structural failure of a filter element which can occur due to abnormally high pressure drop or resistance to flow.

Colloidal

Slime in a liquid; the mucus-like substance created by bacteria.

Contaminant

Any foreign or unwanted substance which can have a negative effect on system operation, longevity or reliability.

Contaminant Failure

Any loss of performance due to the presence of contamination. Two basic types of contamination failure are: Perceptible - gradual loss of efficiency of performance and Catastrophic - Dramatic, unexpected failure. As contaminant becomes caught in the media it begins to build up and fills the pore openings. As the pore openings shrink, the differential pressure (pressure drop) increases. Too much contaminant in the media can cause contaminant migration or element failure if the elements are not removed promptly.

Contaminant Migration

Migration occurs when the restriction is so great that the pressure pushes contaminant deeper in the media and eventually through the media and downstream.

Differential Pressure

(See pressure drop) Also referred to a Delta P (p).

Dissolved Water

Small quantities of water will mix into solution with hydrocarbons. This is called "dissolved water" (sometimes referred to as soluble water, miscible water or bound water). You can relate dissolved water in hydrocarbons as you would moisture in air. Like the weather, if the relative humidity is 50% you know there is water vapor present in the air; however, you cannot see the water or feel it. The same relationship applies to hydrocarbons.

There is a definite limit to how much dissolved water can be held in a hydrocarbon. This limit is referred to as the saturation level (same as 100% relative humidity). The saturation level decreases as the temperature drops and increases as the temperature rises. When the hydrocarbon is exposed to the atmosphere, the hydrocarbon will absorb moisture from the air or release dissolved water to the air until equilibrium is obtained.

GLOSSARY OF TERMS

E-85

This is the term for motor fuel blends of 85 percent ethanol and 15 percent gasoline. Ethanol blends are referred to as Exx. The xx indicates the amount of ethanol in the blend, i.e., E15 (standard blended ethanol fuel) is 15% ethanol and 85% gasoline.

Element Failure

Occurs when the restriction becomes so high that the element collapses or the media ruptures to relieve the upstream pressure.

Emulsified Water

It is still “free water” but in the form of finely dispersed droplets suspended within the hydrocarbon. Causes a slight haze or milky appearance to the hydrocarbon.

Ethanol

(Ethyl) grain alcohol. Typically fermented from grain (corn, sugar cane, etc.). When used as a motor fuel, it is usually an ingredient in a gasoline/alcohol blend as an octane enhancer added at a rate of up to 10% in gasoline. Ethanol is a fuel oxygenate. In the U.S., Ethanol used in gasoline blends is principally derived from corn. In other countries, e.g., Brazil, ethanol used in motor fuels is derived from sugar cane. It is also produced synthetically from petroleum base stocks.

Filter, Pump

A filtering element located inside a gasoline station dispenser which removes impurities that might be present in the motor fuel, just before the fuel enters the dispenser hose on its way to the customer’s vehicle tank.

Filter Efficiency

Method of expressing a filter’s ability to trap and retain contaminants of a given size. Usually given as a percent.

Filter Bypass

Occurs when the fluid upstream of a filter can pass to the outlet of the filter without going through the filter media, allowing contaminant to pass downstream. Fluid flowing through a filter can bypass the filter media for many reasons, such as improperly sealed media seams and endcaps, element ruptures and damaged and misaligned gaskets.

Flow Rate

A term used to describe the speed at which a liquid moves through a system. In the U.S. petroleum operations, the flow rate is usually identified in terms of gpm (Gallons Per Minute). A particular type of gasoline nozzle, for example, might be described as having a flow rate of 10 gpm.

Fluid Filtration

A mechanical means of removing and retaining insoluble contaminants.

Free Water

That water within the hydrocarbon which is not dissolved - generally referring to large droplets which are visible and accumulate below the hydrocarbon at the bottom of the reservoir. Free water can vary in concentration from a few ppm (parts per million) to several percent. However, you can have fuel with a 0 ppm of freewater (visually crystal clear) and yet have 35 to 50 ppm of dissolved water. Free water is described in many different ways such as: “entrained water” or “slugs of water”. “Emulsified” water normally refers to the tightly dispersed droplets, and “suspended” water has a milky haze. The combination of both free and dissolved water is called total water.

Petro Clear water sensing products, (Type “W”), remove only free water and not dissolved water. Type “A” will sense suspended water in gasohols. Testing methods for detection of free water are visual, aqua-glo, centrifuges and turbidity monitors. Total water content is usually determined by the “Karl Fisher Method” (ASTM D 1533).

GLOSSARY OF TERMS

Gasohol

In the United States the term gasohol refers to a blend of gasoline and (usually) 10% ethanol. This term was used in the late 1970s and early 1980s but has been replaced by terms at the pump such as Super Unleaded Plus Ethanol or Unleaded Plus.

Gravimetric Filtration Efficiency Rating

The percentage of contaminants removed by weight. If 100 grams of contaminant are in the stream flow and 80 grams are stopped by the filter being tested, the filter has an efficiency rating of 80%.

Gravity Flow

The movement of liquid caused by the force of gravity. Gravity flow provides the primary method of delivering product to underground storage tanks. Liquid in a hose or pipe that is tilted in a “downhill” direction will, of course, move in that direction, even without any external power source. The pressure that gravity imposes on liquid in a pipe is referred to as the static head.

Hydrocarbon

Any class of compounds consisting of hydrogen and carbon atoms. Gasoline, fuel oil, and other petroleum products are referred to as hydrocarbons, although they usually also contain additives from other chemical groups.

M-85

This is the term for motor fuel blends of 85 percent methanol and 15 percent gasoline. Methanol blends are referred to as Mxx. The xx indicates the amount of ethanol in the blend, i.e., E15 (standard blended ethanol fuel) is 15% ethanol and 85% gasoline.

Methanol

(methyl alcohol, wood alcohol) Typically manufactured from natural gas. In the 1980s methanol was used in combination with heavier co-solvent alcohols as an octane enhancer for addition to gasoline. Methanol is not typically blended into today’s gasoline.

Micron

A unit of length. The commonly used shortened form for micrometer. One micron = 39.4 millionths of an inch (.0000394”). Contaminant size is usually described in microns. Relatively speaking, a grain of salt is about 100 microns, human hair about 70 microns, white blood cell 25 microns, talcum powder 10 microns, red blood cell 8 microns and bacteria is about 2 microns. The smallest an eye can see is about 40 microns.

MTBE

(methyl tertiary butyl ether) An ether manufactured by reacting methanol and isobutylene. The resulting ether is high octane and of low volatility. MTBE is a fuel oxygenate.

Multi-Pass Test

A test sanctioned by the International Standards Organization (ISO) for use in determining a filter’s efficiency and capacity at a specific flow rate.

Nominal Filter Rating

An arbitrary value assigned to the filter by the manufacturer. This value has no meaning whatsoever. It does not signify any characteristic of the filter which can be determined and measured against an accepted standard. The nominal rating sometimes is represented as a value loosely relating to the removal efficiency of the filter. The origins of the term can be traced to an outdated military specification. In defining filter performance, any reference to the so-called nominal rating is strongly discouraged.

NPT

National Pipe Thread. A tapered self sealing thread.

OEM

Original Equipment Manufacturer

GLOSSARY OF TERMS

Oxygenated Gasoline

Gasoline that has been formulated in a way that is designed to reduce carbon monoxide from automotive exhausts. Oxygenates are either alcohols or ether compound, added to gasoline. A number of U.S. communities with severe air pollution problems now mandate use of oxygenated fuels. The regulations generally require that oxygenated gasoline contain 2.7% oxygen by weight (2.0% in California), equivalent to 15% of MTBE (methyl tertiary butyl ether) by volume, or 7.4% of fuel ethanol by volume. Oxygenated gasoline is particularly in demand during the winter months in areas where weather conditions cause increased air-pollution levels. Oxygenates increase the oxygen-to-fuel ratio in an internal combustion engine. This results in a more complete burning of the fuel, and hence reduces the amount of harmful pollutants released into the air.

Paraffin

A wax which is a natural product in crude oil and is dissolved within diesel fuel. Paraffin causes gelling in diesel fuel at low temperatures. When combined with water, it will begin to congeal at higher temperatures.

Phase Separation

The separation of gasoline and alcohol in a storage tank caused by the presence of water or by the addition of warm gasoline to a cold storage tank, particularly in humid coastal areas. Many motor fuels consist of a mixture of gasoline and alcohol. Care must be exercised in the handling of some of these products to ensure that phase separation does not occur.

Pressure

Force per unit area, usually expressed in pounds per square inch.

Pressure Drop

(See differential pressure) The pressure difference between two points, generally at the inlet and outlet. All system components through which there is flow, have a pressure drop. This drop is the net pressure required for the fluid to flow from the inlet to the outlet of the component. (In filters, this includes the pressure from across the housing and filter element.) It varies with flow rate and fluid viscosity. Generally measured in the U.S. in pounds per square inch (psi).

Pressurized System

Pressurized systems at motor fuel dispensing facilities are those in which the pumping unit is located at a position remote from the pump island, typically inside or directly above the tank, and not in the dispenser itself. When one of the dispensers is authorized to dispense fuel, the pump serving that dispenser is turned on. Since the pump may serve several other dispensers, its operation will pressurize all the pipe lines in the system carrying the same product. Leaks in pressurized piping can thus quickly reach a catastrophic level.

Pump, Dispensing

Original gasoline station pumps were truly pumps. By working a hand lever on the side, the operator created a vacuum in the interior pumping unit and this, in turn, "pulled" product up from the storage tank below. Later, electric motors operated suction pumps, with the pumping unit located inside the dispensing device on the island. In most modern gas stations, the actual pumping unit is not located in the dispenser. Rather, it is located in a remote position, within the storage tank.

The mechanism located on the pump island, therefore, is not really a pump. It is, rather, a dispenser. It contains a meter, electronic controls, a length of hose with a nozzle on the end, and quite probably a filtering element. Through long usage, however, the piece of equipment on the pump island continues to be referred to by many people as a "pump" or a "gas pump". To accommodate this usage, it has become common, within the industry to speak of the dispenser as a "dispensing pump" although "dispenser" is more accurate.

GLOSSARY OF TERMS

Strainer

As the name implies, a strainer is a screen - like device fitted into a product line to prevent impurities in a fuel supply from flowing through to the fuel tank of a vehicle or airplane.

Submersible Pump

Also called a submerged turbine pump (STP). A pumping unit located inside a storage tank. Because the pump is positioned near the bottom of the tank, below the liquid level, it is not normally submerged in the fuel - thus, a submersible pump. Installations in which submersible pumps are used are usually referred to as remote systems.

Synthetic Media

Filtration media made up of synthetic fibers that are uniform in size and have a more aerodynamic shape. This creates less resistance to flow and because the synthetic fibers are smaller, more filtration can be done in a given space. This combination of low flow resistance and increased surface area results in improved filtration efficiency and allows contaminants to be trapped throughout the depth of the filter material.

Tank Water Bottoms

Water that may collect on the bottom of motor fuel storage tanks.

ULSD (Ultra-Low Sulfur Diesel)

This is diesel fuel with a sulfur content of 15 ppm (parts per million) or less.

Underwriters Laboratories (UL)

One of the most widely known, nationally-recognized, independent testing services. UL was originally developed by insurance companies for the purpose of establishing the safety and reliability of manufactured products. Hundreds of products - electrical devices, storage tanks, filters, machines, etc. - are said to "bear the UL label." This means these products have been manufactured to standards developed by Underwriters Laboratories. It also means that specimens of the products have, from time to time, been subjected to performance tests conducted by the Laboratories. Having been manufactured to these standards and having passed the tests, the products are authorized to display the UL label. (Note: Underwriters Laboratories of Canada (ULC) is the Canadian counterpart of UL. The services and operations of the two organizations are essentially the same.)

Viscosity

A property of a fluid that has to do with its resistance to flow and hence its rate of improvement. Molasses, for example, is highly viscous fluid - much more viscous than water. Similarly, gasoline is less viscous than diesel fuel. In terms of physics, viscosity is the measure of the extent to which a fluid resists the force tending to cause the fluid to flow. Usually expressed in Centistokes (cSt) or Saybolt Seconds Universal (SSU).

TECHNICAL INFORMATION

FILTER DIMENSIONS

405 SERIES

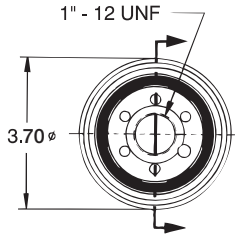
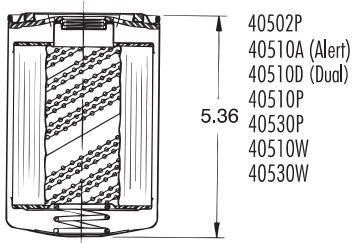

405 WA/PA SERIES

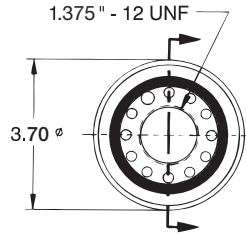
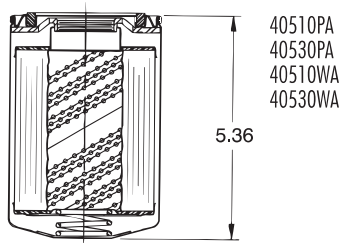

405 W-AD/P-AD SERIES

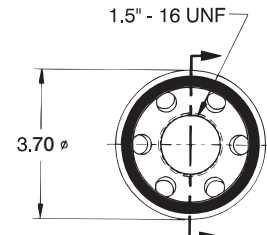
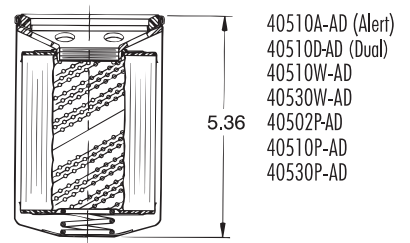

507 SERIES

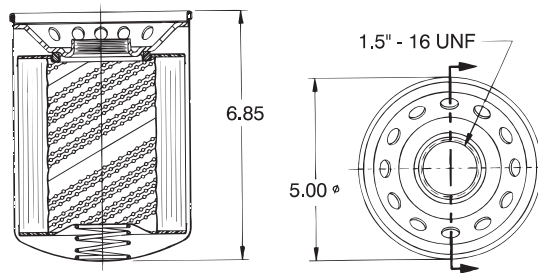

408 PA-DV SERIES

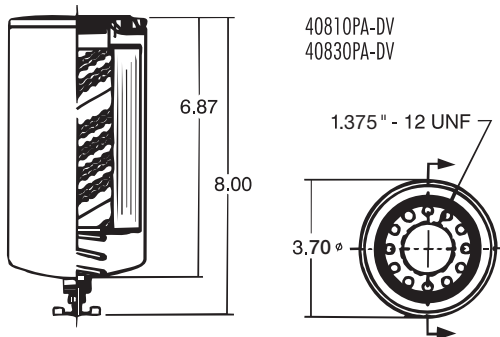

408 DV SERIES

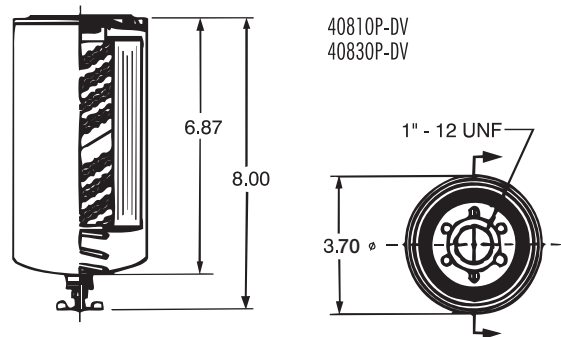

NOTE: If you experience frequent filter changes, it is recommended that you have fuel samples analyzed to determine the source of contamination, such as water, dirt, rust, bacteria, phase separation, etc.

TECHNICAL INFORMATION

FILTER DIMENSIONS

409 SERIES

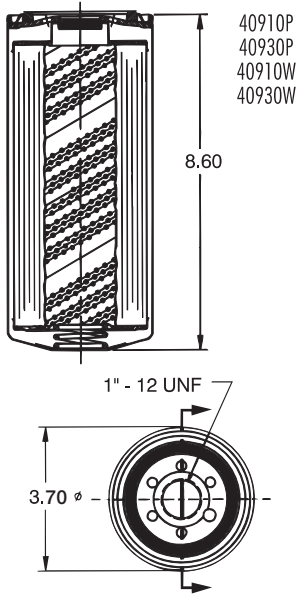

409 PA/WA SERIES

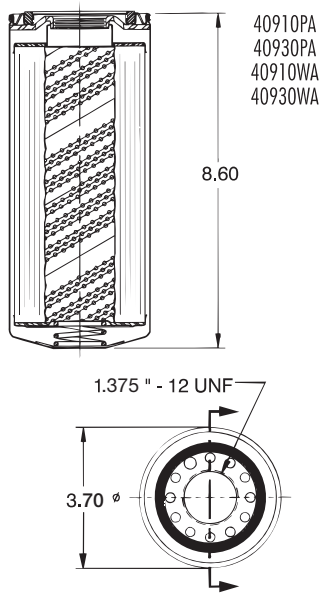

409 P-AD/W-AD SERIES

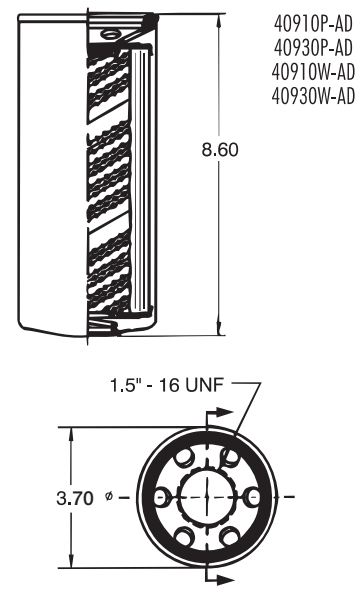

511 SERIES

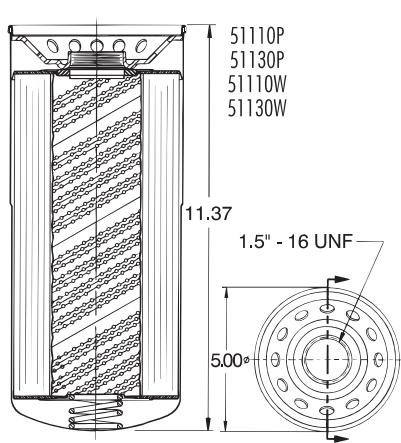

618 SERIES

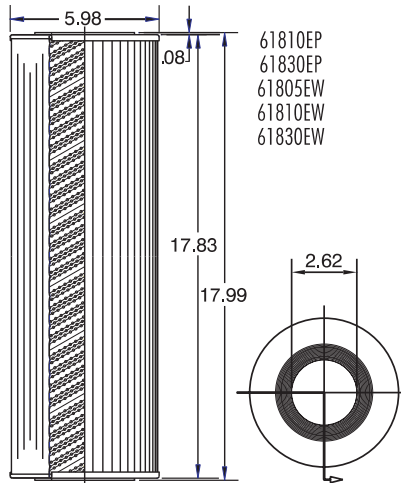

PCP/PCW SERIES

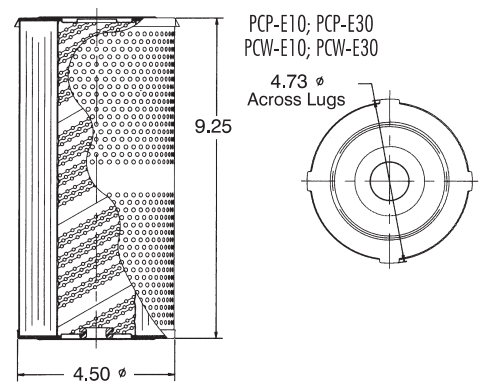

Test Cap TC 1-12

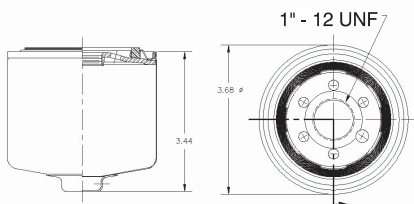

Test Cap TC 1.5-16-AD

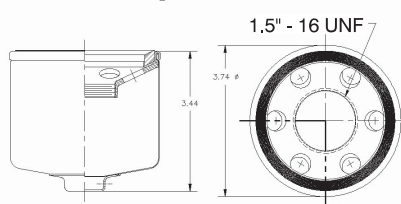

L3561F

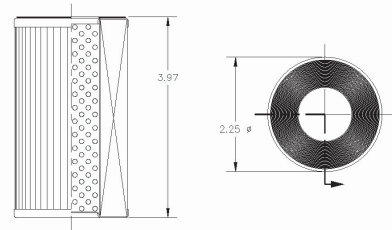

NOTE: If you experience frequent filter changes, it is recommended that you have fuel samples analyzed to determine the source of contamination, such as water, dirt, rust, bacteria, phase separation, etc.

Cross Reference

CIM-TEK	PetroClear	CIM-TEK	PetroClear
70806 / 300-02.....	40502P	70075 / 450HS-10.....	40910W-AD
70808 / 400-02.....	40502P-AD	70076 / 450HS-30.....	40930W-AD
70122 / 300MB-10.....	40510A	70063 / 800HS-10.....	51110W
70120 / 400MB-10.....	40510A-AD	70068 / 800HS-30.....	51130W
70122 / 300MB-10.....	40510D	70019 / 800-10.....	51110P
70120 / 400MB-10.....	40510D-AD	70020 / 800-30.....	51130P
70059 / 300HS-10.....	40510W	30002 / E10.....	PCP-E10
70064 / 300HS-30.....	40530W	30004 / E30.....	PCP-E30
70010 / 300-10.....	40510P	30033 / EHS 10.....	PCW-E10
70012 / 300-30.....	40530P	30036 / EHS 30.....	PCW-E30
70060 / 400HS-10.....	40510W-AD	30001 / 500B-30.....	L3561F
70065 / 400HS-30.....	40530W-AD	30008 / E-1300-10.....	61810EP
70015 / 400-10.....	40510P-AD	30009 / E-1300-30.....	61830EP
70016 / 400-30.....	40530P-AD	30034 / E-1300HS-10.....	61810EW
70002 / 200E-10.....	40810P-DV	30037 / E-1300HS-30.....	61830EW
70046 / 200E-30.....	40830P-DV	50003 / 200H-3/4.....	75N1-12
70004 / 200AE-10.....	40810PA-DV	50181.....	75N1-12A
70045 / 200AE-30.....	40830PA-DV	50002 / 200H-1.....	1.0N1-12
70003 / 250E-10.....	40910P	50004 / 200AH.....	1.0N1-3/8-12
70094 / 260-10.....	40910P	50109.....	1.0N1.5-16
70061 / 260AHS-10.....	40910WA	50163.....	1.5N1.5-16
70066 / 260AHS-30.....	40930WA	50011.....	D2.0N1.5-16
70005 / 250AE-10.....	40910PA	50032.....	1.0N1 5-16AD
70089 / 250AE-30.....	40930PA	60001 / Pre-Vent.....	TV-2
70034 / 450-10.....	40910P-AD	60003 / Pre-Vent Cap.....	TV-RC-2
70027 / 450-30.....	40930P-AD	50001 / 200C.....	TC 1-12

NOTE: If you experience frequent filter changes, it is recommended that you have fuel samples analyzed to determine the source of contamination, such as water, dirt, rust, bacteria, phase separation, etc.

ADAPTER REFERENCE

PART/MODEL #	DESCRIPTION	APPLICATION
	<p>3/4" NPT Inlet/Outlet Ports 1-12 UNF 3/4" Flow (Cast Iron)</p>	<p>40502/5/10/30P 40510PE 40510/30A 40510/30D 40510/30W 40810/30P-DV 40910/30P 40910/30W</p>
<p style="text-align: center;">PetroClear® Part # .75N1-12</p>		
	<p>3/4" NPT Inlet/Outlet Ports 1-12 UNF 3/4" Flow (Aluminum) <i>PetroClear Aluminum Heads are epoxy impregnated.</i></p>	<p>40502/5/10/30P 40510PE 40510/30A 40510/30D 40510/30W 40810/30P-DV 40910/30P 40910/30W</p>
<p style="text-align: center;">PetroClear® Part # .75N1-12A</p>		
	<p>3/4" BSP Inlet/Outlet Ports 1-12 UNF 3/4" Flow (Aluminum) <i>PetroClear Aluminum Heads are epoxy impregnated.</i></p>	<p>40502/5/10/30P 40510PE 40510/30A 40510/30D 40510/30W 40810/3 P-DV 40910/30P 40910/30W</p>
<p style="text-align: center;">PetroClear® Part # .75B1-12</p>		

NOTE: If you experience frequent filter changes, it is recommended that you have fuel samples analyzed to determine the source of contamination, such as water, dirt, rust, bacteria, phase separation, etc.

ADAPTER REFERENCE

PART/MODEL #	DESCRIPTION	APPLICATION
 <p data-bbox="245 940 630 972">PetroClear® Part # 1.0N1-12</p>	<p data-bbox="760 554 1179 621">1" NPT Inlet/Outlet Ports 1-12 UNF 3/4" Flow (Cast Iron)</p>	<p data-bbox="1263 554 1463 814">40502/5/10/30P 40510PE 40510/30A 40510/30D 40510/30W 40810/30P-DV 40910/30P 40910/30W</p>
 <p data-bbox="248 1423 630 1455">PetroClear® Part # 1.0B1-12</p>	<p data-bbox="760 1031 1198 1098">1" BSP Inlet/Outlet Ports 1-12 UNF 3/4" Flow (Aluminum)</p> <p data-bbox="760 1115 1081 1173"><i>PetroClear Aluminum Heads are epoxy impregnated.</i></p>	<p data-bbox="1263 1031 1463 1291">40502/5/10/30P 40510PE 40510/30A 40510/30D 40510/30W 40810/30P-DV 40910/30P 40910/30W</p>
 <p data-bbox="237 1902 643 1934">PetroClear® Part # 1.0N1-12A</p>	<p data-bbox="760 1514 1198 1581">1" NPT Inlet/Outlet Ports 1-12 UNF 3/4" Flow (Aluminum)</p> <p data-bbox="760 1598 1081 1656"><i>PetroClear Aluminum Heads are epoxy impregnated.</i></p>	<p data-bbox="1263 1514 1446 1774">40502/10/30P 40510PE 40510/30A 40510/30D 40510/30W 40810/30P-DV 40910/30P 40910/30W</p>

NOTE: If you experience frequent filter changes, it is recommended that you have fuel samples analyzed to determine the source of contamination, such as water, dirt, rust, bacteria, phase separation, etc.

ADAPTER REFERENCE

PART/MODEL #	DESCRIPTION	APPLICATION
 <p>PetroClear® Part # 1.0N1 3/8-12</p>	<p>1" NPT Inlet/Outlet Ports 1.375-12 UNF 1" Flow (Cast Iron)</p>	<p>40510/30PA 40510/30WA 40810/30PA-DV 40910/30PA 40910/30WA</p>
 <p>PetroClear® Part # .75N1.5-16AD</p>	<p>3/4" NPT Inlet/Outlet Ports 1.5-16 UNF 1" Flow (Aluminum) <i>PetroClear Aluminum Heads are epoxy impregnated.</i> (Fits AD filters only with a 3.70" diameter)</p>	<p>40502/5/10/30P-AD 40510PE-AD 40510/30A-AD 40510/30D-AD 40510/30W-AD 40910/30P-AD 40910/30W-AD</p>
 <p>PetroClear® Part # .75B1.5-16AD</p>	<p>3/4" BSP Inlet/Outlet Ports 1.5-16 UNF 1" Flow (Aluminum) <i>PetroClear Aluminum Heads are epoxy impregnated.</i> (Fits AD filters only with a 3.70" diameter)</p>	<p>40502/5/10/30P-AD 40510PE-AD 40510/30A-AD 40510/30D-AD 40510/30W-AD 40910/30P-AD 40910/30W-AD</p>

NOTE: If you experience frequent filter changes, it is recommended that you have fuel samples analyzed to determine the source of contamination, such as water, dirt, rust, bacteria, phase separation, etc.

ADAPTER REFERENCE

PART/MODEL #	DESCRIPTION	APPLICATION
	<p>1" NPT Inlet/Outlet Ports 1.5 –16 UNF 1" Flow (Aluminum)</p> <p><i>PetroClear Aluminum Heads are epoxy impregnated.</i></p> <p>(Fits AD filters only with a 3.70" diameter)</p> <p>*Will not fit 5" diameter filters</p>	<p>40502/5/10/30P-AD 40510PE-AD 40510/30A-AD 40510/30D-AD 40510/30W-AD 40910/30P-AD 40910/30W-AD</p>
<p>PetroClear® Part # 1.0N1.5-16AD</p>		
	<p>1" BSD Inlet/Outlet Ports 1.5 –16 UNF 1" Flow (Aluminum)</p> <p><i>PetroClear Aluminum Heads are epoxy impregnated.</i></p> <p>(Fits AD filters only with a 3.70" diameter)</p> <p>*Will not fit 5" diameter filters</p>	<p>40502/5/10/30P-AD 40510PE-AD 40510/30A-AD 40510/30D-AD 40510/30W-AD 40910/30P-AD 40910/30W-AD</p>
<p>PetroClear® Part # 1.0B1.5-16AD</p>		
	<p>1" NPT Inlet/Outlet Ports 1.5-16 UNF 1" Flow (Aluminum)</p> <p><i>PetroClear Aluminum Heads are epoxy impregnated.</i></p>	<p>50710P 50710W 51103/10/30P 51110/30W 51110/30A</p>
<p>PetroClear® Part # 1.0N1.5-16</p>		



NOTE: If you experience frequent filter changes, it is recommended that you have fuel samples analyzed to determine the source of contamination, such as water, dirt, rust, bacteria, phase separation, etc.

ADAPTER REFERENCE

PART/MODEL #	DESCRIPTION	APPLICATION
	<p>1-1/2" NPT Inlet/Outlet Ports 1.5-16 UNF 1" Flow (Aluminum)</p> <p><i>PetroClear Aluminum Heads are epoxy impregnated.</i></p>	<p>50710P 50710W 51103/10/30P 51110/30W 51110/30A</p>
<p>PetroClear® Part # 1.50N1.5-16</p>		
	<p>2" NPT Inlet/Outlet Ports Bolt Flange Inlet/Outlet Ports 1.5 –16 UNF 1" Flow (Aluminum)</p> <p><i>PetroClear Aluminum Heads are epoxy impregnated.</i></p>	<p>50710P 50710W 51103/10/30P 51103/10/30W 51110/30A</p>
<p>PetroClear® Part # D2.0N1.5-16</p>		
	<p>1" BSP Inlet/Outlet Ports 1.5-16 UNF 1" Flow (Aluminum)</p> <p><i>PetroClear Aluminum Heads are epoxy impregnated.</i></p>	<p>50710P 50710W 51103/10/30P 51110/30W 51110/30A</p>
<p>PetroClear® Part # 1.0B1.5-16</p>		



NOTE: If you experience frequent filter changes, it is recommended that you have fuel samples analyzed to determine the source of contamination, such as water, dirt, rust, bacteria, phase separation, etc.

ADAPTER REFERENCE

PART/MODEL #	DESCRIPTION	APPLICATION
 <p>PetroClear® Part # TC1-12</p>	<p>Test Cap for 1-12 UNF Filters 3/4" Flow</p> <ul style="list-style-type: none"> ■ Interior Epoxy Coating. ■ UL recognized for Ethanol blended fuels. ■ Designed for use with gasoline and diesel including Ethanol blended gasoline to E85, Biodiesel and ULSD (Ultra Low Sulfur Diesel). <p>PetroClear® FILTERS ARE NOT TO BE USED IN AVIATION FUEL APPLICATIONS.</p>	<p>Use in place of these filters: 40502/5/10/30P 40510PE 40510/30A 40510/30D 40510/30W 40810/30P-DV 40910/30P 40910/30W</p>
 <p>PetroClear® Part # TC1.5-16 AD</p>	<p>Test Cap for 1.5-16 UNF Filters 1" Flow</p> <ul style="list-style-type: none"> ■ Interior Epoxy Coating. ■ UL recognized for Ethanol blended fuels. ■ Designed for use with gasoline and diesel including Ethanol blended gasoline to E85, Biodiesel and ULSD (Ultra Low Sulfur Diesel). <p>PetroClear® FILTERS ARE NOT TO BE USED IN AVIATION FUEL APPLICATIONS.</p>	<p>Use in place of these filters: 40502/5/10/30 P-AD 40510PE-AD 40510/30A-AD 40510/30D-AD 40510/30W-AD 40910/30P-AD 40910/30W-AD</p>

NOTE: If you experience frequent filter changes, it is recommended that you have fuel samples analyzed to determine the source of contamination, such as water, dirt, rust, bacteria, phase separation, etc.

ADAPTER REFERENCE

PART/MODEL #	DESCRIPTION
	<p>PetroClear® Tank Vent 2" Fill Cap Base fits a standard 2" NPT threaded hole.</p>
<p>PetroClear® Part # TV-2</p>	<p>PetroClear® FILTERS ARE NOT TO BE USED IN AVIATION FUEL APPLICATIONS.</p>
	<p>PetroClear® Tank Vent 2" (Replacement Cap)</p>
<p>PetroClear® Part # TV-RC-2</p>	<p>PetroClear® FILTERS ARE NOT TO BE USED IN AVIATION FUEL APPLICATIONS.</p>

NOTE: If you experience frequent filter changes, it is recommended that you have fuel samples analyzed to determine the source of contamination, such as water, dirt, rust, bacteria, phase separation, etc.