

411 Series

Particulate Removing



41110P and 41130P
Extended Life Particulate
(For Dispenser Use)

FOR DISPOSAL INFORMATION PLEASE CONTACT YOUR NEAREST EPA OFFICE.

Benefits

- PetroClear® models 41110P and 41130P are particulate removing spin-on filters designed to remove particulate from neat gasoline, Ethanol blended gasolines, diesels, Biodiesel, ULSD (Ultra Low Sulfur Diesel), kerosene and fuel oils.
- PetroClear® models 41110P and 41130P are particulate spin-on filters. These filters are designed for particulate removal only and WILL NOT REACT TO WATER IN NEAT GASOLINE OR DETECT PHASE SEPARATION IN ETHANOL BLENDED GASOLINES TO SLOW FLOW.
- PetroClear® model 41110P filter offers efficient 10 micron (nominal) particulate removal.
- PetroClear® model 41130P filter offers efficient 30 micron (nominal) particulate removal.
- Textured paint coating helps ensure a simple, mess-free installation and removal process.
- UL® recognized
- Compatible with neat gasoline, Diesels, Biodiesel and Ethanol blended fuels.

PetroClear® Filters are NOT to be used in Aviation Fuel Applications!

Specifications

- The PetroClear® model 41110P utilizes a 10 micron (nominal) cellulose media to remove particulate from gasoline and diesel fuels including Ethanol blended gasoline, Biodiesel and ULSD (Ultra Low Sulfur Diesel). Removes particulate 10 microns (nominal) or larger.
- The PetroClear® model 41130P utilizes a 30 micron (nominal) cellulose media to remove particulate from gasoline and diesel fuels including Ethanol blended gasoline, Biodiesel and ULSD (Ultra Low Sulfur Diesel). Removes particulate 30 microns (nominal) or larger.
- The maximum flow rate for PetroClear® models 41110P and 41130P is 25 gpm (94.6 lpm). Maximum operating pressure is 50 psid (3.4 bar). Collapse pressure is 150 psid (10.3 bar). Maximum operating temperature is 250°F (139°C).
- PetroClear® models 41110P and 41130P utilize a standard 1" – 12 UNF mounting thread ref. (3/4" flow) required for most spin-on filter Adapters used in Gilbarco, Wayne, Bennett, Tokheim and other major manufacturers' dispensers, as well as with Adapters used in the aftermarket.
- Adapters are available for models 41110P and 41130P in aluminum and cast iron. Single Adapters are available in both 3/4" and 1" NPT and BSP inlet/outlet threads.

NOTE: If you experience frequent filter changes, it is recommended that you have fuel samples analyzed to determine the source of contamination, such as water, dirt, rust, bacteria, phase separation, etc.

41110P and 41130P

For Fuel Dispensers

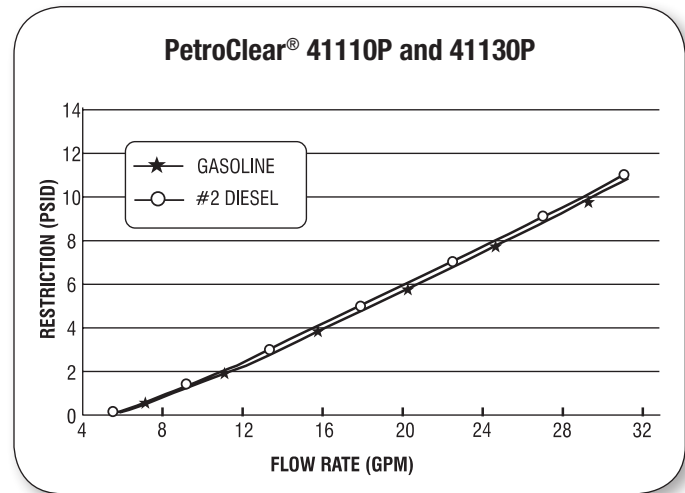
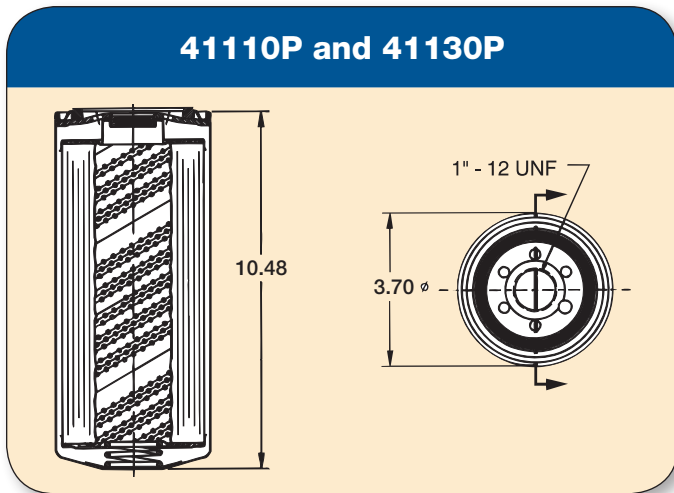

Model	41110P	41130P
Filter Type	Spin-On	Spin-On
Media Type	*Cellulose	*Cellulose
Micron Rating	10 Micron (nominal)	30 Micron (nominal)
Diameter	3.70"	3.70"
Height	10.48"	10.48"
Mounting Thread	1" - 12 UNF	1" - 12 UNF
Flow Rate	25 gpm (94.6 lpm)	25 gpm (94.6 lpm)
Flow	3/4" flow	3/4" flow
Shell Thickness	0.020	0.020
Gasket Material	Buna N	Buna N
Collapse (Min.)	150 psid (10.3 bar)	150 psid (10.3 bar)
Burst (Min.)	250 psi (17.2 bar)	250 psi (17.2 bar)
Max. Operating Temp.	250°F (139°C)	250°F (139°C)

*Particulate Removing

Available Adapters

Part/Model Number	Description
0.75 N1-12	3/4" NPT Inlet/Outlet Ports, 1" - 12 UNF (cast iron)
.75 N1-12A	3/4" NPT Inlet/Outlet Ports, 1" - 12 UNF (aluminum)
1.0 N1-12	1" NPT Inlet/Outlet Ports, 1" - 12 UNF (cast iron)
1.0 N1-12A	1" NPT Inlet/Outlet Ports, 1" - 12 UNF (aluminum)
.75 B1-12	3/4" BSP Inlet/Outlet Ports, 1" - 12 UNF (aluminum)
1.0 B1-12	1" BSP Inlet/Outlet Ports, 1" - 12 UNF (aluminum)