

411-AD Series

Particulate Removing



41110P-AD and 41130P-AD

Extended Life Particulate
For High-Flow Fuel Dispensers

FOR DISPOSAL INFORMATION PLEASE CONTACT YOUR NEAREST EPA OFFICE.

Benefits

- The 41110P-AD and 41130P-AD are designed to remove particulate from gasoline, Ethanol blended gasolines, diesels, Biodiesel, ULSD (Ultra Low Sulfur Diesel), Kerosene and fuel oils.
- PetroClear® models 41110P-AD and 41130P-AD are particulate spin-on filters. These filters are designed for particulate removal only and WILL NOT REACT TO WATER IN NEAT GASOLINE OR DETECT PHASE SEPARATION IN ETHANOL BLENDED GASOLINE TO SLOW FLOW.
- PetroClear® model 41110P-AD filter offers efficient 10 micron (nominal) particulate removal.
- PetroClear® model 41130P-AD filter offers efficient 30 micron (nominal) particulate removal.
- Textured paint coating helps ensure a simple, mess-free installation and removal process.
- UL® recognized
- Compatible with neat gasoline, Ethanol blended fuels and all diesels including Biodiesels.

PetroClear® Filters are NOT to be used in Aviation Fuel Applications!

Specifications

- The PetroClear® model 41110P-AD utilizes a 10 micron (nominal) cellulose media to remove particulate from gasolines and diesel fuels including Ethanol blended gasoline, Biodiesel and ULSD (Ultra Low Sulfur Diesel). Removes particulate 10 microns (nominal) or larger.
- The PetroClear® model 41130P-AD utilizes a 30 micron (nominal) cellulose media to remove particulate from gasolines and diesel fuels including Ethanol blended gasoline, Biodiesel and ULSD (Ultra Low Sulfur Diesel). Removes particulate 30 microns (nominal) or larger.
- The maximum flow rate for PetroClear® models 41110P-AD and 41130P-AD is 25 gpm (94.6 lpm). Maximum operating pressure is 50 psid (3.4 bar). Collapse pressure is 150 psid (10.3 bar). Maximum operating temperature is 250°F (139°C).
- PetroClear® models 41110P-AD and 41130P-AD utilize a standard 1.5"-16 UNF mounting thread ref. (1" flow) required for most spin-on filter Adapters used in aftermarket and/or high-flow applications, such as in Gilbarco, Wayne, Bennett, Tokheim and other major manufacturers' dispensers.
- Adapters are available for models 41110P-AD and 41130P-AD in aluminum. These single Adapters are available in 3/4" and 1" NPT and BSP inlet/outlet threads.

NOTE: If you experience frequent filter changes, it is recommended that you have fuel samples analyzed to determine the source of contamination, such as water, dirt, rust, bacteria, phase separation, etc.

41110P-AD and 41130P-AD

Extended Life for High-Flow Fuel Dispensers

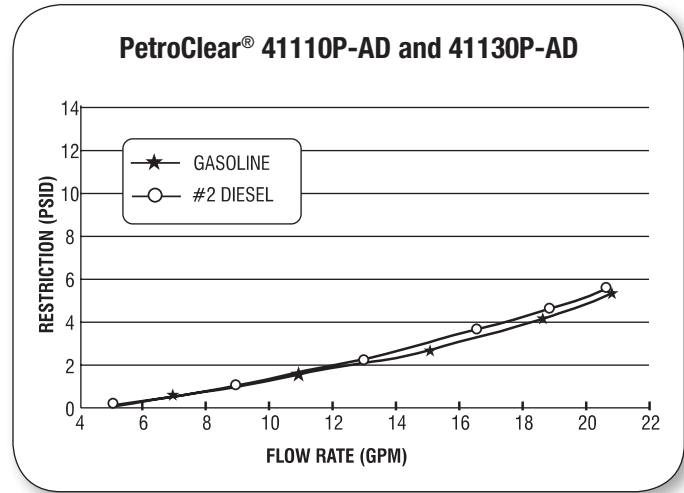
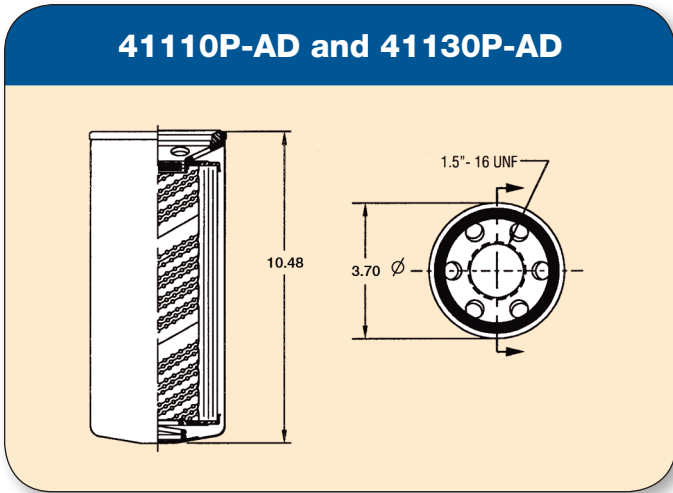

Model	41110P-AD	41130P-AD
Filter Type	Spin-On	Spin-On
Media Type	*Cellulose	*Cellulose
Micron Rating	10 Micron (nominal)	30 Micron (nominal)
Diameter	3.70"	3.70"
Height	10.48"	10.48"
Mounting Thread	1.5" – 16 UNF	1.5" – 16 UNF
Flow Rate	25 gpm (94.6 lpm)	25 gpm (94.6 lpm)
Flow	1" flow	1" flow
Shell Thickness	0.020	0.020
Gasket Material	Buna N	Buna N
Collapse (Min.)	150 psid (10.3 bar)	150 psid (10.3 bar)
Burst (Min.)	500 psi (34.5 bar)	500 psi (34.5 bar)
Max. Operating Temp.	250°F (139°C)	250°F (139°C)

*Particulate Removing

Available Adapters

Part/Model Number	Description
.75 N1.5-16AD	3/4" NPT Inlet/Outlet Ports, 1.5" – 16 UNF (aluminum)
1.0 N1.5-16AD	1" NPT Inlet/Outlet Ports, 1.5" – 16 UNF (aluminum)
.75 B1.5-16AD	3/4" BSP Inlet/Outlet Ports, 1.5"-16 UNF (aluminum)
1.0 B1.5-16AD	1" BSP Inlet/Outlet Ports, 1.5"-16 UNF (aluminum)