

411 D-AD Series “Dual Purpose”

Removes Particulate,
Detects Phase Separation & Senses Water

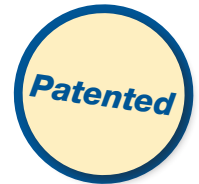

41110D-AD and 41130D-AD

Detects and Reacts to Phase Separation in Ethanol Blends and Senses Water in Gasoline, Diesel and Biodiesel

FOR DISPOSAL INFORMATION PLEASE CONTACT YOUR NEAREST EPA OFFICE.

Benefits

- PetroClear® models 41110D-AD and 41130D-AD are spin-on filters designed to remove particulate in gasoline, ethanol blends, diesel and biodiesel. PetroClear® models 41110D-AD and 41130D-AD sense both free and emulsified water in neat gasoline, diesel and biodiesel. PetroClear® models 41110D-AD and 41130D-AD detect and react to phase separation in Ethanol blended gasoline and slow flow as an indicator to the presence of phase separation.
- PetroClear® model 41110D-AD offers efficient 10 micron (nominal) particulate removal, senses both free and emulsified water and detects and reacts to phase separation.
- PetroClear® model 41130D-AD offers efficient 30 micron (nominal) particulate removal, senses both free and emulsified water and detects and reacts to phase separation.
- The “dual purpose” models provide protection during the transition from neat gasoline to ethanol blends without the need to change filters.
- Textured paint coating helps ensure a simple, mess-free installation and removal process.
- UL® recognized.

PetroClear® Filters are NOT to be used in Aviation Fuel Applications!

Specifications

- The PetroClear® model 41110D-AD utilizes a 10 micron (nominal) cellulose media to remove particulate 10 microns (nominal) or larger from neat gasoline, ethanol blends, diesel and biodiesel. The PetroClear® model 41110D-AD also senses water in neat gasoline, diesel and biodiesel. The PetroClear® model 41110D-AD provides phase separation detecting capabilities for ethanol-blended gasoline. It utilizes a super absorbent media for sensing water and a chemical core assembly to detect and react to phase separation.
- The PetroClear® model 41130D-AD utilizes a 30 micron (nominal) cellulose media to remove particulate 30 microns (nominal) or larger from neat gasoline, ethanol blends, diesel and biodiesel. The PetroClear® model 41130D-AD also senses water in neat gasoline, diesel and biodiesel. The PetroClear® model 41130D-AD provides phase separation detecting capabilities for ethanol-blended gasoline. It utilizes a super absorbent media for sensing water and a chemical core assembly to detect and react to phase separation.
- Once PetroClear® models 41110D-AD and 41130D-AD have absorbed 12.8 ounces (378 mil) of water, flow will be noticeably slow.
- The center chemical core assembly detects and reacts to phase separation and significantly restricts flow through filters.
- The maximum flow rate for PetroClear® models 41110D-AD and 41130D-AD is 25 gpm (94.6 lpm). Maximum operating pressure is 50 psid (3.4 bar).
- Collapse pressure is 150 psid (10.3 bar). Maximum operating temperature is 250°F (139°C).
- PetroClear® models 41110D-AD and 41130D-AD “Dual Purpose” high-flow filters utilize a standard 1.5” – 16 UNF mounting thread ref. (1” flow) required for most spin-on filter adapters used in aftermarket and/or today’s high-flow fuel applications such as in Gilbarco, Wayne, Bennett, Tokheim and other major manufacturers’ dispensers.
- Adapters are available for models 41110D-AD and 41130D-AD in aluminum. These single Adapters are available in both 3/4” and 1” NPT and BSP inlet/outlet threads.

NOTE: If you experience frequent filter changes, it is recommended that you have fuel samples analyzed to determine the source of contamination, such as water, dirt, rust, bacteria, phase separation, etc.

41110D-AD and 41130D-AD “Dual Purpose”

Removes Particulate, Detects Phase Separation & Senses Water

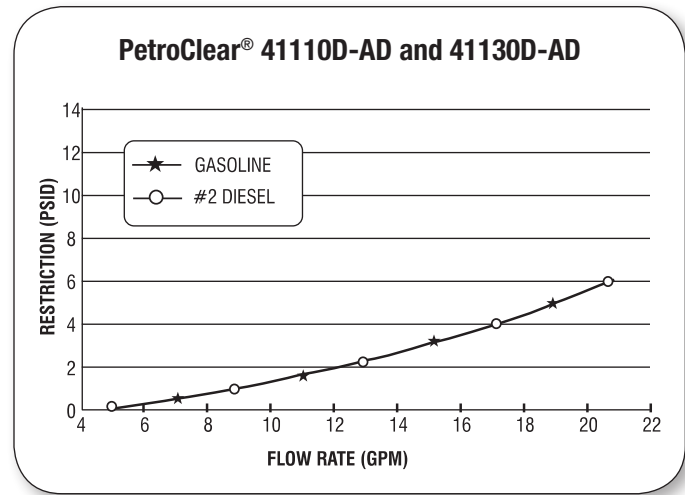
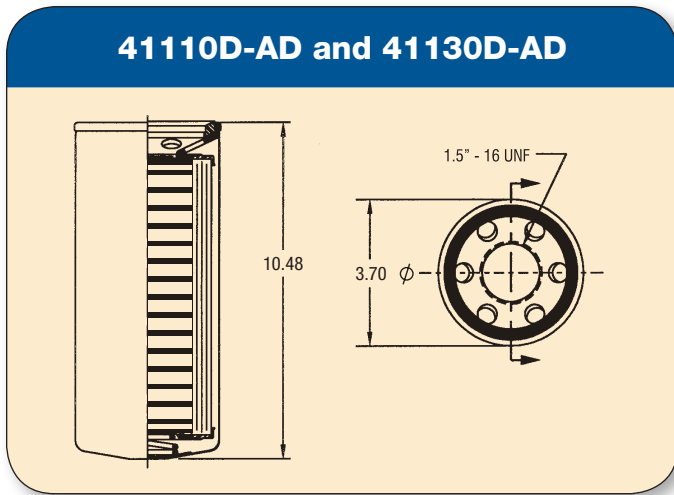

Model	41110D-AD	41130D-AD
Filter Type	Spin-On	Spin-On
Media Type	Cellulose* with Super Absorbent Media** and Chemical Core***	Cellulose* with Super Absorbent Media** and Chemical Core***
Micron Rating	10 Micron (nominal)	30 Micron (nominal)
Diameter	3.70"	3.70"
Height	10.48"	10.48"
Mounting Thread	1.5" – 16 UNF	1.5" – 16 UNF
Flow Rate	25 gpm (94.6 lpm)	25 gpm (94.6 lpm)
Flow	1" flow	1" flow
Shell Thickness	0.020	0.020
Gasket Material	Buna N	Buna N
Collapse (Min.)	150 psid (10.3 bar)	150 psid (10.3 bar)
Burst (Min.)	500 psi (34.5 bar)	500 psi (34.5 bar)
Max. Operating Temp.	250°F (139°C)	250°F (139°C)
Min. Operating Temp.	-20°F (-28.9°C)	-20°F (-28.9°C)

*Particulate Removing, **Water Sensing, ***Detects Phase Separation

Available Adapters

Part/Model Number	Description
.75 N1.5-16AD	3/4" NPT Inlet/Outlet Ports, 1.5" – 16 UNF (aluminum)
1.0N1.5-16AD	1" NPT Inlet/Outlet, 1.5" – 16 UNF (aluminum)
.75B1.5-16AD	3/4" BSP Ports, 1"-16 UNF (aluminum)
1.0B1.5-16AD	1" BSP Ports, 1"-16 UNF (aluminum)