

411 Series

Water Sensing & Particulate Removing



41110W and 41130W

Extended Life Water Sensing
For Dispenser Use

FOR DISPOSAL INFORMATION PLEASE CONTACT YOUR NEAREST EPA OFFICE.

Benefits

- The 41110W and 41130W are designed to remove particulate and to sense both free and emulsified water from neat gasoline, diesel, Biodiesel, ULSD (Ultra Low Sulfur Diesel), Kerosene, and fuel oils. This filter will not sense nor react to water in Ethanol-blended gasoline. (Reaction known as phase separation)
- PetroClear® models 41110W and 41130W are particulate and water sensing spin-on filters. These filters are designed to sense water, both free and emulsified, and slow flow as an indicator of the presence of water in neat gasoline and diesel fuels.
- PetroClear® model 41110W filter offers efficient 10 micron (nominal) particulate removal and senses both free and emulsified water in neat gasoline and diesel fuels.
- PetroClear® model 41130W filter offers efficient 30 micron (nominal) particulate removal and senses both free and emulsified water in neat gasoline and diesel fuels.
- Textured paint coating helps ensure a simple, mess-free installation and removal process.
- UL® recognized
- Will not detect phase separation in Ethanol blended fuels.

PetroClear® Filters are NOT to be used in Aviation Fuel Applications!

Specifications

- The PetroClear® model 41110W utilizes a 10 micron (nominal) cellulose media to remove particulate from gasoline and diesel fuels including Biodiesel and ULSD (Ultra Low Sulfur Diesel). Removes particulate 10 microns (nominal) or larger, with water sensing capability in neat gasoline and diesel fuels.
- The PetroClear® model 41130W utilizes a 30 micron (nominal) cellulose media to remove particulate from gasoline and diesel fuels including Biodiesel and ULSD (Ultra Low Sulfur Diesel). Removes particulate 30 microns (nominal) or larger, with water sensing capability in neat gasoline and diesel fuels.
- Once PetroClear® models 41110W and 41130W have absorbed 12.8 ounces (378 mil) of water from neat gasoline or diesel fuel, flow will be noticeably slow.
- The maximum flow rate for PetroClear® models 41110W and 41130W is 25 gpm (94.6 lpm). Maximum operating pressure is 50 psid (3.4 bar). Collapse pressure is 150 psid (10.3 bar). Maximum operating temperature is 250°F (139°C).
- PetroClear® models 41110W and 41130W utilize a standard 1"-12 UNF mounting thread ref. (3/4" flow) required for most spin-on filter Adapters used in Gilbarco, Wayne, Bennett, Tokheim and other major manufacturers' dispensers, as well as with Adapters used in the aftermarket.
- Adapters are available for models 41110W and 41130W in aluminum and cast iron. These single Adapters are available in both 3/4" and 1" NPT or BSP inlet/outlet threads.

NOTE: If you experience frequent filter changes, it is recommended that you have fuel samples analyzed to determine the source of contamination, such as water, dirt, rust, bacteria, phase separation, etc.

4110W and 41130W

For Fuel Dispensers

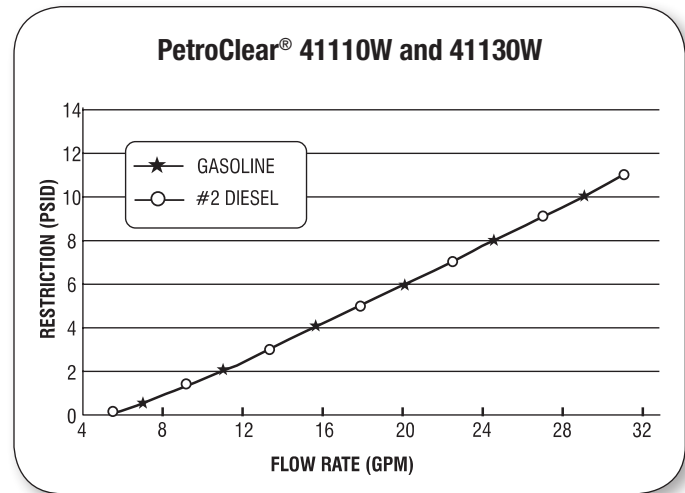
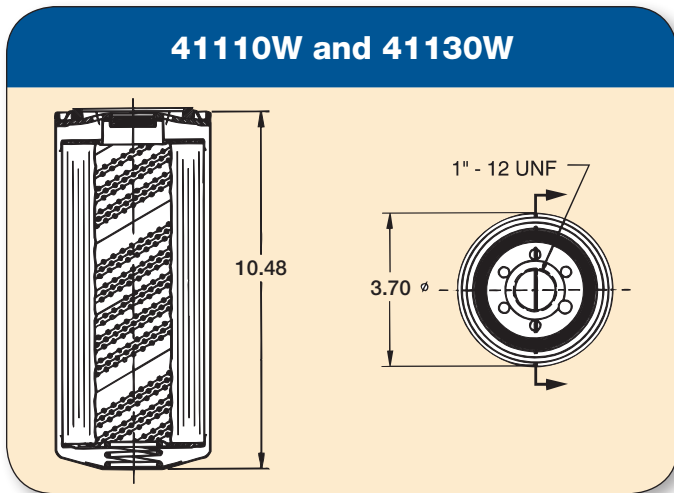

| Model | 4110W | 41130W |
|----------------------|---------------------------------------|---------------------------------------|
| Filter Type | Spin-On | Spin-On |
| Media Type | *Cellulose with Super Absorbent Media | *Cellulose with Super Absorbent Media |
| Micron Rating | 10 Micron (nominal) | 30 Micron (nominal) |
| Diameter | 3.70" | 3.70" |
| Height | 10.48" | 10.48" |
| Mounting Thread | 1" - 12 UNF | 1" - 12 UNF |
| Flow Rate | 25 gpm (94.6 lpm) | 25 gpm (94.6 lpm) |
| Flow | 3/4" flow | 3/4" flow |
| Shell Thickness | 0.020 | 0.020 |
| Gasket Material | Buna N | Buna N |
| Collapse (Min.) | 150 psid (10.3 bar) | 150 psid (10.3 bar) |
| Burst (Min.) | 250 psi (17.2 bar) | 250 psi (17.2 bar) |
| Max. Operating Temp. | 250°F (139°C) | 250°F (139°C) |

*Water Sensing & Particulate Removing

Available Adapters

| Part/Model Number | Description |
|-------------------|--|
| .75 N1-12 | 3/4" NPT Inlet/Outlet Ports, 1" - 12 UNF (cast iron) |
| .75 N1-12A | 3/4" NPT Inlet/Outlet Ports, 1" - 12 UNF (aluminum) |
| 1.0 N1-12 | 1" NPT Inlet/Outlet Ports, 1" - 12 UNF (cast iron) |
| 1.0 N1-12A | 1" NPT Inlet/Outlet Ports, 1" - 12 UNF (aluminum) |
| .75 B1-12 | 3/4" BSP Inlet/Outlet Ports, 1" - 12 UNF (aluminum) |
| 1.0 B1-12 | 1" BSP Inlet/Outlet Ports, 1" - 12 UNF (aluminum) |