

411 Series “Alert”

Particulate Removal and Phase Separation Detection In Alcohol Blended Fuels



41110A and 41130A

Detects Phase Separation in
Ethanol Blended Gasoline

FOR DISPOSAL INFORMATION PLEASE CONTACT YOUR NEAREST EPA OFFICE.

Benefits

- The “Alert” models 41110A and 41130A are designed to remove particulate and to detect and react to phase separation in Ethanol blended gasoline and slow flow as an indicator to the presence of phase separation. IT WILL NOT SENSE NOR REACT TO WATER IN NON-ALCOHOL BLENDED GASOLINE (NEAT GASOLINE).
- PetroClear® model 41110A filter offers efficient 10 micron (nominal) particulate removal and detects phase separation.
- PetroClear® model 41130A filter offers efficient 30 micron (nominal) particulate removal and detects phase separation.
- Textured paint coating helps ensure a simple, mess-free installation and removal process.
- UL® recognized

PetroClear® Filters are NOT to be used in Aviation Fuel Applications!

Specifications

- The PetroClear® model 41110A utilizes a 10 micron (nominal) cellulose media to remove particulate from Ethanol blended gasoline. Removes particulate 10 microns (nominal) or larger.
- The PetroClear® model 41130A utilizes a 30 micron (nominal) cellulose media to remove particulate from Ethanol blended gasoline. Removes particulate 30 microns (nominal) or larger.
- The “Alert” models 41110A and 41130A are designed to detect and react to phase separation in Ethanol blended gasoline.
- The maximum flow rate for PetroClear® models 41110A and 41130A is 25 gpm (94.6 lpm). Maximum operating pressure is 50 psid (3.4 bar). Collapse pressure is 150 psid (10.3 bar). Maximum operating temperature is 250°F (139°C).
- The chemical center core assembly detects and reacts to phase separation and significantly restricts flow through filters.
- PetroClear® models 41110A and 41130A utilize a standard 1"-12 UNF mounting thread ref. (3/4" flow) required for most spin-on filter adapters used in aftermarket.
- Adapters are available for models 41110A and 41130A in aluminum and cast iron. These single adapters are available in both 3/4" and 1" NPT or BSP inlet/outlet threads.

NOTE: If you experience frequent filter changes, it is recommended that you have fuel samples analyzed to determine the source of contamination, such as water, dirt, rust, bacteria, phase separation, etc.

41110A and 41130A Series the "Alert" Detects Phase Separation

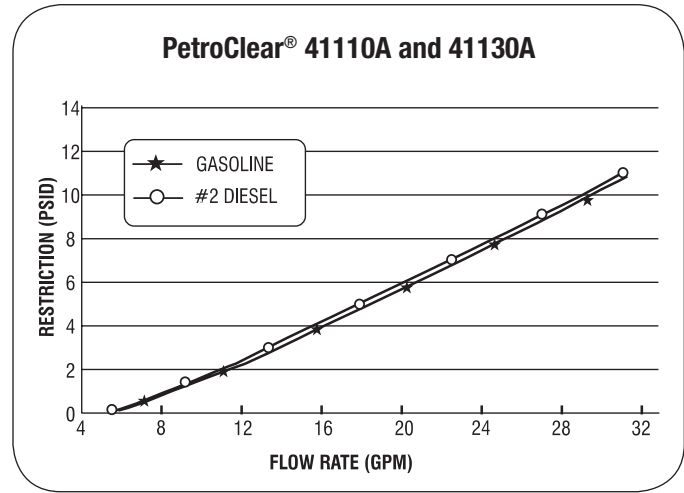
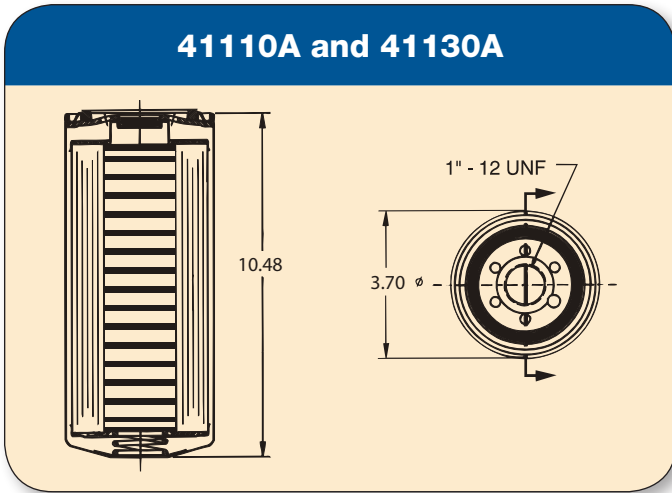

Model	41110A	41130A
Filter Type	Spin-On	Spin-On
Media Type	*Cellulose with Chemical Core	*Cellulose with Chemical Core
Micron Rating	10 Micron (nominal)	30 Micron (nominal)
Diameter	3.70"	3.70"
Height	10.48"	10.48"
Mounting Thread	1" - 12 UNF	1" - 12 UNF
Flow Rate	25 gpm (94.6 lpm)	25 gpm (94.6 lpm)
Flow	3/4" flow	3/4" flow
Shell Thickness	0.020	0.020
Gasket Material	Buna N	Buna N
Collapse (Min.)	150 psid (10.3 bar)	150 psid (10.3 bar)
Burst (Min.)	250 psi (17.2 bar)	250 psi (17.2 bar)
Max. Operating Temp.	250°F (139°C)	250°F (139°C)
Min. Operating Temp.	-20°F (-28.9°C)	-20°F (-28.9°C)

*Particulate Removing and Chemical Core Detects Phase Separation

Available Adapters

Part/Model Number	Description
.75 N1-12	3/4" NPT Inlet/Outlet Ports, 1" - 12 UNF (cast iron)
.75 N1-12A	3/4" NPT Inlet/Outlet Ports, 1" - 12 UNF (aluminum)
1.0 N1-12	1" NPT Inlet/Outlet Ports, 1" - 12 UNF (cast iron)
1.0 N1-12A	1" NPT Inlet/Outlet Ports, 1" - 12 UNF (aluminum)
.75 B1-12	3/4" BSP Inlet/Outlet Ports, 1" - 12 UNF (aluminum)
1.0 B1-12	1" BSP Inlet/Outlet Ports, 1" - 12 UNF (aluminum)