

# 405 Series

## Particulate Removing & Water Sensing



**40510W and 40530W**  
Water Sensing in Neat Gasoline and Diesels

FOR DISPOSAL INFORMATION PLEASE CONTACT YOUR NEAREST EPA OFFICE.

### Benefits

- PetroClear® models 40510W and 40530W are particulate removing and water sensing spin-on filters designed to remove particulate and to sense both free and emulsified water from neat gasoline, diesel, Biodiesel, ULSD (Ultra Low Sulfur Diesel), kerosene and fuel oils.
- PetroClear® models 40510W and 40530W are particulate and water sensing spin-on filters. These filters are designed to sense water, both free and emulsified, and slow flow as an indicator of the presence of water in neat gasoline and diesel fuels. This filter will not sense nor react to water in Ethanol blended gasoline. (Reaction known as phase separation)
- PetroClear® model 40510W filter offers efficient 10 micron (nominal) particulate removal and senses both free and emulsified water in neat gasoline and diesel fuels.
- PetroClear® model 40530W filter offers efficient 30 micron (nominal) particulate removal and senses both free and emulsified water in neat gasoline and diesel fuels.
- Textured paint coating helps ensure a simple, mess-free installation and removal process.
- UL® recognized
- Will not detect phase separation in Ethanol blended fuels.

**PetroClear® Filters are NOT to be used in Aviation Fuel Applications!**

### Specifications

- The PetroClear® model 40510W utilizes a 10 micron (nominal) cellulose media to remove particulate from gasolines and diesel fuels including Biodiesel and ULSD (Ultra Low Sulfur Diesel). Removes particulate 10 microns (nominal) or larger. This filter utilizes a super absorbent chemical that is laminated to the filter media for water sensing capabilities in neat gasoline and diesel fuels.
- The PetroClear® model 40530W utilizes a 30 micron (nominal) cellulose media to remove particulate from gasolines and diesel fuels including Biodiesel and ULSD (Ultra Low Sulfur Diesel). Removes particulate 30 microns (nominal) or larger. It utilizes a super absorbent chemical that is laminated to the filter media for water sensing capabilities in neat gasoline and diesel applications.
- When PetroClear® models 40510W and 40530W absorb 5.9 ounces (175 mil) of water from neat gasoline or diesel fuels, flow will be noticeably slow.
- The maximum flow rate for PetroClear® models 40510W and 40530W is 25 gpm (94.6 lpm). Maximum operating pressure is 50 psid (3.4 bar). Collapse pressure is 150 psid (10.3 bar). Maximum operating temperature is 250°F (139°C).
- PetroClear® models 40510W and 40530W utilize a standard 1.5"-12 UNF mounting thread ref. (3/4" flow) required for most spin-on filter Adapters used in aftermarket and/or high-flow applications such as Gilbarco, Wayne, Bennet, Tokheim and other major manufacturers' dispensers.
- Adapters are available for models 40510W and 40530W in aluminum and cast iron. These single Adapters are available in 3/4" and 1" NPT or BSP inlet/outlet threads.

**NOTE:** If you experience frequent filter changes, it is recommended that you have fuel samples analyzed to determine the source of contamination, such as water, dirt, rust, bacteria, phase separation, etc.

# 40510W and 40530W

## For Fuel Dispensers

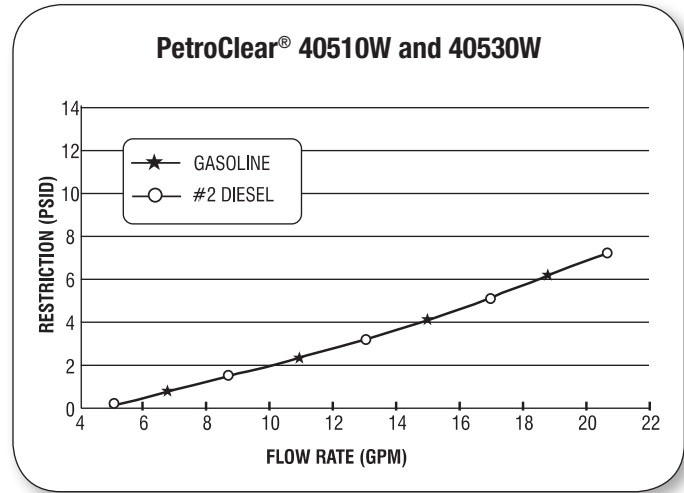
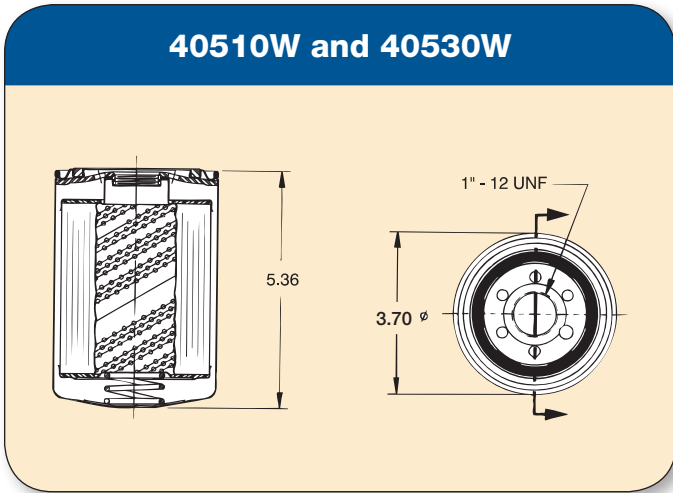

Model	40510W	40530W
Filter Type	Spin-On	Spin-On
Media Type	*Cellulose with Super Absorbent Media	*Cellulose with Super Absorbent Media
Micron Rating	10 Micron (nominal)	30 Micron (nominal)
Diameter	3.70"	3.70"
Height	5.36"	5.36"
Mounting Thread	1" – 12 UNF	1" – 12 UNF
Flow Rate	25 gpm (94.6 lpm)	25 gpm (94.6 lpm)
Flow	3/4" flow	3/4" flow
Shell Thickness	0.020	0.020
Gasket Material	Buna N	Buna N
Collapse (Min.)	150 psid (10.3 bar)	150 psid (10.3 bar)
Burst (Min.)	250 psi (17.2 bar)	250 psi (17.2 bar)
Max. Operating Temp.	250°F (139°C)	250°F (139°C)
Min. Operating Temp.	-20°F (-28.9°C)	-20°F (-28.9°C)

\*Water Sensing and Particulate Removing

Adapters Available	Catalog	Description
	0.75 N1-12	3/4" NPT Inlet/Outlet Ports, 1" – 12 UNF (cast iron)
	0.75 N1-12A	3/4" NPT Inlet/Outlet Ports, 1" – 12 UNF (aluminum)
	1.00 N1-12	1" NPT Inlet/Outlet Ports, 1" – 12 UNF (cast iron)
	1.00 N1-12A	1" NPT Inlet/Outlet Ports, 1" – 12 UNF (aluminum)
	0.75 B1-12	3/4" BSP Inlet/Outlet Ports, 1" – 12 UNF (aluminum)
	1.00 B1-12	1" BSP Inlet/Outlet Ports, 1" – 12 UNF (aluminum)